



**Energy Management**  
**solutions** for compressed  
air and industrial gases



**'VPVision** is a really powerful tool to keep our compressed air consumption at the lowest possible level. It helps us to prevent leakage and to optimize our compressed air supply.'

- Kikkoman Europe



# Our mission

VPIInstruments develops, produces and supplies energy management solutions for compressed air and industrial gases. We show you where, when and how much you can save. Our solutions cover both supply side and demand side. We offer a unique product range consisting of:

- > Insertion and in-line flow meters and other sensors for compressed air and technical gases
- > Energy Management Software for compressed air and all other utilities
- > Easy to use tools for installation

VPIInstruments is one of the most innovative companies in its industry. Our products and solutions are often unique in the market, easy to use, sustainably produced, and designed with two eyes for detail, which is reflected in our logo. Our products are sold through skilled distributors worldwide. Thanks to their skills and expertise, they help you to get the most out of our products.

We take quality and traceability very seriously. Our calibration systems are traceable to the National Standards at NMI (Dutch Institute of Standards and Metrology). Our quality management system is certified to ISO 9001:2008.

## Proudly serving leading companies worldwide

Through our distributors and dealers, we serve clients worldwide to save on compressed air energy costs. A small selection of end users: Astrum UK (Steel castings), Bolletje (Food), GSK (Medicines), Kikkoman Foods, Libbey (Glass), Mars (Food), Nedstaal (Steel production), Nestlé (Food), O&I (Glass), Philips (Consumer goods), Rexam (Glass), Toyota (Automotive).



## History

**Since 1974**, the founders of VPIInstruments have invested over 40 years in research

**In 1999**, VPIInstruments is founded by Pascal van Putten, and wins the McKinsey New Venture '98 competition

**In 2007**, The VPFlowScope product line is launched. For the first time, mass flow, pressure and temperature can be measured with a single probe

**In 2009**, VPVision is introduced. The complete solution for compressed air energy management

**In 2011**, The VPFlowScope Differential Pressure flow meter is introduced. Now you can perform air audits in wet, condensing air conditions

**In 2013**, VPIInstruments again sets the standard with a three in one in-line flow sensor

**In 2014:** VPIInstruments celebrates their 15 year anniversary

# Technology

## Thermabridge- leading sensor technology since 1974

Our co-founder Anton Van Putten invented the world's first solid state thermal mass flow sensor back in 1974. We are proud to continue the heritage of making cutting edge products based upon this unique and patented sensor technology.

## Working principle

The unique Thermabridge™ sensors are integrated circuits, just like computer chips. They combine a heater with a Wheatstone bridge. The heater keeps the sensor on a constant temperature. The Wheatstone bridge is used for temperature control and direction measurement.

## Direction sensitivity. Invented by VPInstruments

The VPFlowScope combines an extremely large measurement range with integrated direction sensitivity. This patented feature enables you to measure in loop networks, and in systems with air receivers. These situations used to be very difficult to assess. With the VPFlowScope, flow direction is no longer a mystery.

## Modbus - the industry standard

The VPFlowScope provides a Modbus-RTU interface, which opens the door to many energy management software packages and building management systems. No secret protocols or expensive configuration tools needed.

## Sensing the future

Since 1974, the founders of VPInstruments have invested over 40 years in research and development. We will continue to do so, to enhance our products and our technology, in our effort to provide the best possible solutions for mass flow measurement of compressed air and technical gases.

The unique Thermabridge™ sensors combine a heating element with a Wheatstone bridge.

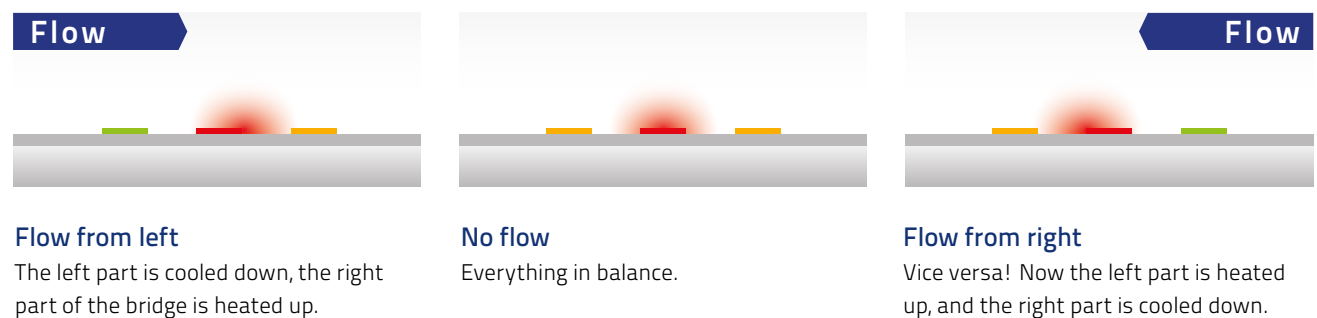

# If you can measure it, you can improve it

## Measure

p11



### Use mass flow meters for:

- > Supply side air: pre-treated wet oily dirty air
- > Demand side air: clean dry air
- > Piping systems from 0.5" up to 20": measuring and recording mass flow, temperature and pressure in a single measuring instrument
- > Air audits, system checks

## Monitor

p27



### Leave measuring equipment in place to:

- > Continually know what is happening in your system
- > Proactively control leaks
- > Plan your maintenance based on real-time actions
- > Monitor dew point, power consumption and pressure loss to prevent downtime

## Manage

p31



### With VPVision you can:

- > Track and manage your leakage
- > Allocate compressed air costs to individual departments
- > Deliver cost evaluation and savings reports
- > Benchmark different plants around the world on efficiency and costs
- > Produce necessary documentation for utility incentives

## Install

p35



### We offer a line of tools and accessories for:

- > Hot tapping: Installation of flow meters under pressurized conditions
- > Leak detection
- > Measuring pipe wall thickness

# Measure, Discover and Save!

Compressed air is a very expensive energy source. In fact, it is nearly 10 times more expensive than electricity.

Studies show that up to 50% of generated compressed air is still lost due to leakage, incompetent use and overdue maintenance. Our products enable you to chart these losses easily.

In many cases, compressed air demand can be reduced by optimizing the compressed air system with proper air management, pressure control, piping configurations and air leak control.

Compressed air consumption

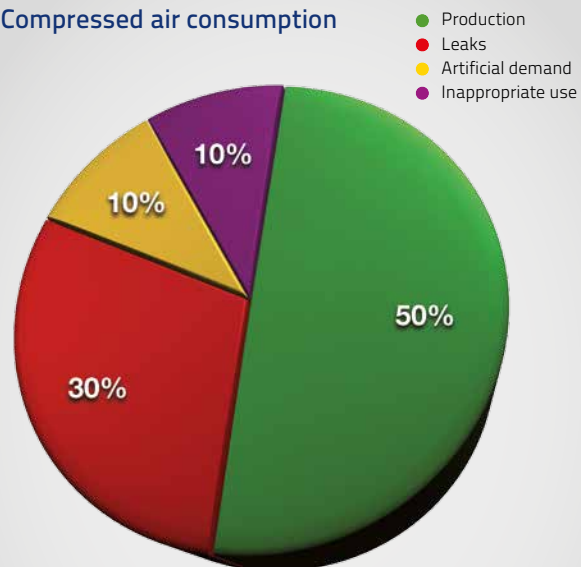

Fact: Only 50% of the generated compressed air is used usefully. The other 50% is being spilled. A management system will help you to reduce this waste of energy and money, and helps you to maintain your consumption as low as possible.

## Maximize your ROI

Your return on investment can be a matter of months. Take a look at customer savings success stories on our website, and read how our products have helped companies save energy year after year.

kW	ANNUAL ELECTRICITY BILL			SAVINGS POTENTIAL		
	kW/Year	Euro	USD	Euro/Year	USD/Year	ROI (days)
25	109,500	€ 16,425	\$ 19,710	€ 4,928	\$ 5,913	365
37	162,060	€ 24,309	\$ 29,171	€ 7,293	\$ 8,751	247
55	240,900	€ 36,135	\$ 43,362	€ 10,841	\$ 13,009	166
125	547,500	€ 82,125	\$ 98,550	€ 24,638	\$ 29,565	73
250	1,095,000	€ 164,250	\$ 197,100	€ 49,275	\$ 59,130	37

Equipment investment	€ 5,000
Leakage/savings potential	30%
Production hours per day	12
kW price	€ 0.15

Did you know that a 2 inch in-line meter guards a cash flow of more than 10,000 Euro per year? The ROI is in general a matter of months! See our website for more savings examples and calculators.

# Compressed air applications

Virtually any production plant utilizes compressed air. Applications are packaging machines, offset presses, transport of granulate and food ingredients, cooling of products, and tank aeration.

- > Ceramic factories
- > Glass production
- > Cement and construction products
- > Paper
- > Food production, beverage and breweries
- > Life sciences
- > Automotive
- > Steel production

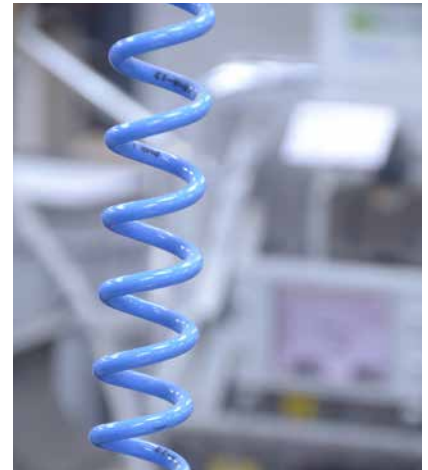

# Other markets and applications

Our products are used successfully in various industrial applications, for example:

- > Aeration monitoring in water treatment plants
- > Airflow monitoring in large ducts
- > General test and measurement applications (such as universities)
- > OEM applications
- > Combustion air mixing
- > Technical gas mixing
- > Welding gas, packaging gas
- > CO2 consumption metering
- > CO2 exhaust metering

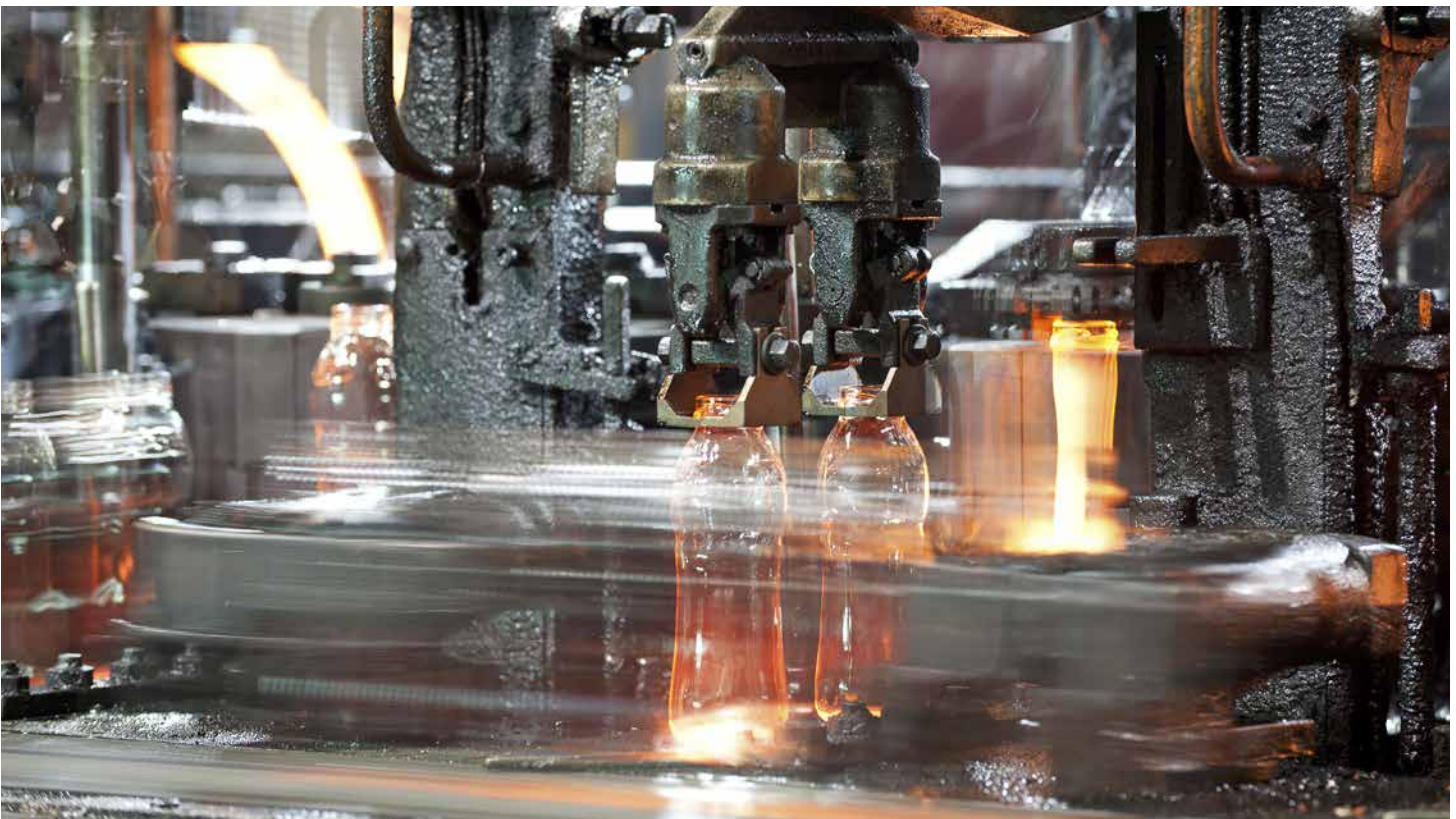



# Application examples and start kits

We offer start kits, which can be directly applied to your application. Each start kit contains all the items you need for the job.



## Portable audit tools

The VPFlowScope® measures mass flow, pressure, and temperature and features a built-in two million point data logger. The device has a built-in display with keypad for configuration: no need to bring a computer on-site! The start kit is delivered in a heavy duty weather proof transport case. Complete with a portable power supply adapter, cables and VPStudio™ software.

### Order codes

#### VPFlowScope®

VPS.R150.P400.KIT

VPS.R200.P4DP.KIT

VPFlowScope start kit for dry air

VPFlowScope start kit for wet air, high temperature

## Demand side measurement

For small compressors, demand side and point of use measurement, we offer the VPFlowScope in-line three in one mass flow meter with built-in two million point data logger and USB interface. We offer three models that fit virtually all demand side applications.

PIPE SIZES			CAPACITY			
DN	Thread <sup>1</sup>	Models	Qmin (m <sup>3</sup> <sub>n</sub> /hr)	Qmax (m <sup>3</sup> <sub>n</sub> /hr)	Qmin (scfm) <sup>2</sup>	Qmax (scfm) <sup>2</sup>
15	1/2"	VPS.R080.M050	0.2	80	0.1	45
25	1"	VPS.R250.M100	0.9	250	0.5	145
50	2"	VPS.R01K.M200	3.6	1000	2.2	580

<sup>1</sup> All models supplied with BSP thread (straight). For US NPT, an adapter is available

<sup>2</sup> SCFM values are rounded off



## Power supply and interface options

All power supplies are rated for 90 to 230 V input with 12 to 24 V output and supplied with correct plug for the country of destination.

ORDER CODES	DESCRIPTION	APPLICATION
VPA.0000.200	Power supply with M12 connector	Light industrial, portable use
VPA.5000.005	M12 cable, 5 meter	Fixed installations, control panels



## Compressed air supply monitoring

For overall efficiency and cost monitoring we provide a complete solution. It consists of the VPFlowTerminal wall mount display, the VPFlowScope and an AC current sensor. With an optional dew point sensor, you can also monitor the dew point to make sure it is within the specified range.

### Order codes

VPT.5110.000

VPFlowTerminal for VPFlowScope. Including display with built-in data logger. Pre-mounted connector for VPFlowScope. Built-in power supply. Includes black connector cap with cable 10m/32.9ft, 4 Analogue inputs for VPFlowTerminal. Data will be logged simultaneously. Configuration and read out with VPStudio.

#### Flow meters

VPS.R200.P4DP

Flow, pressure, temperature measurement, for wet air

VPS.R150.P400

Flow, pressure, temperature measurement, for dry air

#### Current sensors

VPA.8000.2100

VPLog-i AC current sensor 100A-rms

VPA.8000.2200

VPLog-i AC current sensor 200A-rms

VPA.8000.2400

VPLog-i AC current sensor 400A-rms

VPA.8000.2800

VPLog-i AC current sensor 800A-rms

VPA.8000.21K5

VPLog-i AC current sensor 1500A-rms

### Dew point sensors

APPLICATION	DEW POINT	CONNECTION	ORDER CODES
Adsorption dryer	-100 ... +20°C   -148 ... 68°F	4 ... 20 mA 2 wire	VPA.8000.1003
Refrigerant dryer	-40 ... +60°C   -40 ... 140 °F	4 ... 20 mA 3 wire	VPA.8000.1013

## Example: VPFlowTerminal for local data logging

- > 1 VPFlowScope
- > 3 parameters on local display
- > Up to 8 parameters to be logged
- > Example: 4 analog inputs (4 ... 20 mA)
  - > 2 Current clamps (Amps)
  - > 1 Pressure sensor (Air treatment DP)
  - > 1 dew point meter (Air treatment Quality)
  - > VPFlowScope and all 4 ... 20 mA signals can be patched to DCS



# Service programs

Our service programs provide you with a time- and money saving solution for your VPFlowScope in-line flow meters and insertion probes. With the VPInstruments service programs your equipment will retain their high quality standard and the accuracy you need for your process.

Our pressurized calibration systems are state of the art, strictly maintained under the ISO 9001 certified Quality Management System.

VPInstruments understand the importance of continuity in your production processes and production data. We use the latest lean process improvement techniques to speed up our service processes. Our fully automated calibration process and our 99.97% first pass parts order fill rate are constantly helping to minimize your service order turnaround time. Our unique back-up and restore offering keeps your settings secure and reduces your set-up time after the service to zero.



## Order codes

VPA.0001.920

Standard service subscription. A three or five year contract that includes Parts replacement, Repair, Preventive maintenance. Hardware- and software upgrades. For one fixed price.

VPA.0001.940

Exchange service subscription. A three or five year contract. Receive annually a calibrated instrument and exchange it for the instrument in your possession. Lifetime warranty extension. No service waiting time.





# Measure

'If you can measure it, you can improve it'

- Lord Kelvin



# VPFlowScope

The VPFlowScope measures mass flow, temperature and pressure simultaneously. It's the ultimate compressed air audit tool, used by leading auditors worldwide. The bright blue display provides real-time information, and with the built-in data logger, recording is as easy as taking a picture.

VPStudio software can be used for real-time measurements on your PC, to process data and to print reports. The VPFlowScope product family consists of a wet and a dry air flow meter, which are fully interchangeable and compatible with the VPFlowScope display modules.

## Applications

- > Air audits
- > Demand side monitoring, sub metering of compressed air
- > Ring networks (bi-directional)
- > Air, Nitrogen, Carbon Dioxide, Argon, and any other dry and non-corrosive gases

We offer the VPFlowScope for both wet and dry compressed air. You can combine either sensor module with the same display module. That's why the VPFlowScope is such an exceptional instrument for air auditors. With the VPFlowScope you can measure virtually any compressed air system using a single instrument.



# VPFlowScope

- > Mass Flow, Pressure & Temperature
- > Display/data logger module for easy recording of data
- > Bi-directional measurements (optional)



# Specifications

## VPFlowScope

### Flow sensor

Measuring principle	Thermabridge™ Thermal Mass Flow sensor
Flow range	0 (0.5) ... 150 m <sub>n</sub> /sec   0 ... 500 sfps Bi-directional option (calibrated in positive direction only).
Accuracy	2% of reading under calibration conditions; Please refer to the user manual for details. Recommended pipe diameter: 25 mm (1 inch) and up.
Reference conditions	0 °C, 1013.25 mbar   32 °F, 14.65 psi
Gases	Compressed air, Nitrogen and inert, non condensing gases
Gas temperature range	0 ... +60 °C   0 ... +140 °F

### Pressure sensor

Pressure sensor range PN16	0 ... 16 bar   0 ... 250 psi gauge
Accuracy	+/- 1.5% FSS Temperature compensated
Pressure sensor range PN35 (optional)	0 ... 35 bar   0 ... 500 psi gauge

### Temperature sensor

Temperature sensor range	0 ... +60 °C   0 ... +140 °F
Accuracy	> 10 m/sec: +/- 1 °C   1.8 °F < 10 m/sec: +5 °C   1.8 °F

### Data outputs

Digital	RS485, MODBUS RTU protocol
Analog	4 ... 20 mA output, selectable via software to indicate flow, pressure or temperature

### Display/data logger

Technology	Liquid Crystal (LCD)
Back light	Blue, with auto power save
Data logger	2 million points

### Mechanical & environmental

Probe lengths	400 mm   15 inch (other lengths on request)
Process connection	Compression fitting, 0,5 inch
Pressure rating	PN16   PN35
Protection grade	IP52   NEMA 12 when mated to display module, avoid upside down installation IP63   NEMA 4 when mated to connector cap, avoid upside down installation
Ambient temperature range	-10 ... +50 °C   14 ... 122 °F. Avoid direct sunlight or radiant heat Higher ambient temperatures: consult factory
Wetted materials	Anodized Aluminum, Stainless steel 316, Glass, Epoxy
Corrosion resistance	Highly corrosive or acid environments should be avoided

### Electrical

Connection type	M12, 5 pin connector, female
Power supply	12 ... 24 VDC +/- 10 % Class 2 (UL)
Power consumption	2,4 Watt (no flow) 4,8 Watt (full flow) +/- 10% 100 mA (no flow). 200 mA (full flow) +/- 10% @24VDC
UL/ CUL	14 AZ, Industrial Control Equipment
CE	EN 61326-1, EN 50082-1

# Technical drawings

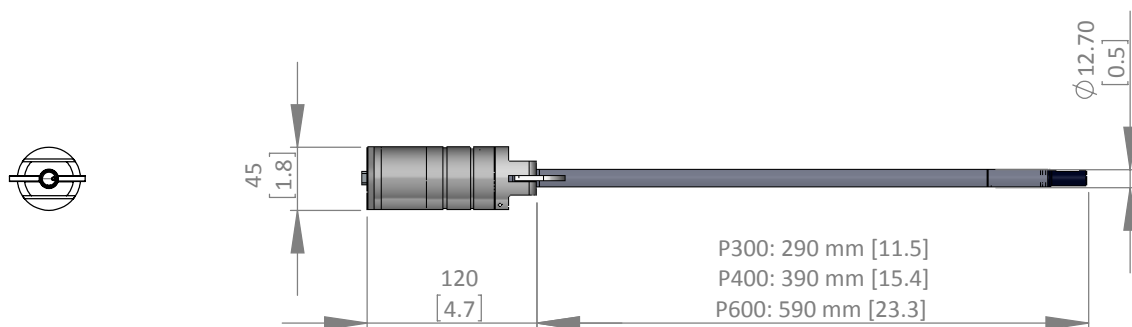

## Order codes

### Flow meters

VPS.R150.P400.KIT  
VPS.R150.P400.D11

VPFlowScope start kit, for air audits, complete with software  
VPFlowScope with 2 million point data logger display module, for auditors and permanent installation (stand alone)

VPS.R150.P400.D10  
VPS.R150.P400.D2

VPFlowScope with three row display  
VPFlowScope with connector cap. For modbus networks

### Other probe lengths

The standard P400 probe is acceptable for most air audits and installations. We offer P300 and P600 probes on request.

### Accessories

VPA.5000.005  
VPA.5001.105  
VPA.5001.900

Cable, M12, 5 pole, for permanent connection  
Interface box JB5 with 5m/ 16.4 ft cable + 12 VDC power supply  
Connector cap with M12 socket for VPFlowScope sensor module

## VPS.R150.P400 flow range table

SCHEDULE 40 STANDARD SEAMLESS CARBON STEEL PIPE								SCHEDULE 10 STANDARD SEAMLESS CARBON STEEL PIPE					
Size (inch)	DN	ID (inch)	ID (mm)	Min flow (scfm)	Max flow (scfm)	Min flow (m <sup>3</sup> <sub>n</sub> /hr)	Max flow (m <sup>3</sup> <sub>n</sub> /hr)	ID (inch)	ID (mm)	Min flow (scfm)	Max flow (scfm)	Min flow (m <sup>3</sup> <sub>n</sub> /hr)	Max flow (m <sup>3</sup> <sub>n</sub> /hr)
2	50	2.1	52.5	2	688	4	1,169	2.2	54.8	2	749	4	1,273
3	80	3.1	77.9	5	1,516	9	2,576	3.3	82.8	6	1,712	10	2,908
4	100	4.0	102.3	9	2,610	15	4,435	4.3	108.2	10	2,923	17	4,966
6	150	6.1	154.1	20	5,924	34	10,065	6.4	161.5	22	6,508	37	11,057
8	200	8.0	202.7	34	10,259	58	17,429	8.3	211.6	37	11,173	63	18,982
10	250	10.2	259.1	56	16,756	95	28,468	10.4	264.7	58	17,487	99	29,709
12	300	11.9	303.2	77	22,953	130	38,995	12.4	314.7	82	24,724	140	42,004
16	400	15.0	381.0	121	36,237	205	61,565	15.6	396.8	131	39,315	223	66,794
20	500	18.8	477.8	190	56,996	323	96,832	19.6	496.9	205	61,643	349	104,729

The ranges apply only to compressed air and nitrogen. Contact us for other gases. The field accuracy of an insertion probe is typically +/- 5% due to installation conditions. Insertion probes may not be used for official compressor testing.





'The **VPFlowScope** enables us to perform air audits quicker, easier and more cost effective. It is the Swiss army knife for any compressed air auditor'

- Air Energy Management, UK



## VPFlowScope dP

- > Extreme resistance to pollution and water drops
- > Mass Flow, Pressure & Temperature
- > Display/data logger module for easy recording of data

## VPFlowScope dP

The VPFlowScope dP is designed for wet air<sup>1</sup>. When properly applied, it can be used in the discharge of the compressor. The VPFlowScope dP is fully compatible with the standard VPFlowScope, which means that it is easy to install and operate without additional training.

### Typical applications

- > Wet air, untreated compressed air<sup>1</sup>
- > High temperature up to 150 °C (302 °F)
- > High velocity applications (undersized pipes)

<sup>1</sup> The VPFlowScope dP can be used up to a high water content (saturated air). However, as it's based on the Pitot principle, some limitations apply: The rangeability is smaller, no vertical lines, no overflowing with water. See user manual for details.

# Specifications

## VPFlowScope dP

### Flow sensor

Measuring principle	Differential pressure
Flow range	20 ... 200 m <sub>n</sub> /sec   65 ... 650 sfps Bi-directional measurement
Accuracy	2% of reading over 1:10 range, under calibration conditions; Please refer to the user manual for details. Recommended pipe diameter: 50 mm (2 inch) and up.
Reference conditions	0 °C, 1013.25 mbar   32 °F, 14.65 psi
Gases	Wet compressed air, Dry compressed air, Nitrogen and Inert gases.

### Pressure sensor

Pressure sensor range	0 ... 16 bar   0 ... 250 psi gauge
Accuracy	+/- 1.5% FSS Temperature compensated

### Temperature sensor

Temperature sensor range	-40 ... +150 °C   -40 ... +302 °F. Icing should be avoided
Accuracy	+/- 1 °C   1.8 °F

### Data outputs

Digital	RS485, MODBUS RTU protocol
Analog	4 ... 20 mA output, selectable via software to indicate flow, pressure or temperature

### Display/data logger

Technology	Liquid Crystal (LCD)
Back light	Blue, with auto power save
Data logger	2 million points

### Mechanical & environmental

Probe lengths	400 mm   15 inch (other lengths on request)
Process connection	Compression fitting, 0,5 inch
Pressure rating	PN16
Protection grade	IP52   NEMA 12 when mated to display module IP63   NEMA 4 when mated to connector cap - do not mount upside down
Ambient temperature range	-10 ... +50 °C   14 ... 122 °F. Avoid direct sunlight or radiant heat Higher ambient temperatures: consult factory
Wetted materials	Anodized Aluminum, Stainless steel 316, Epoxy
Corrosion resistance	Highly corrosive or acid environments should be avoided

### Electrical

Connection type	M12, 5 pin connector, female
Power supply	12 ... 24 VDC +/- 10% Class 2 (UL)
Power consumption	1 Watt +/- 10% 50 mA +/- 10% @24VDC, constant over the entire flow range
UL/ CUL	14 AZ, Industrial Control Equipment
CE	EN 61326-1, EN 50082-1



# Technical drawings

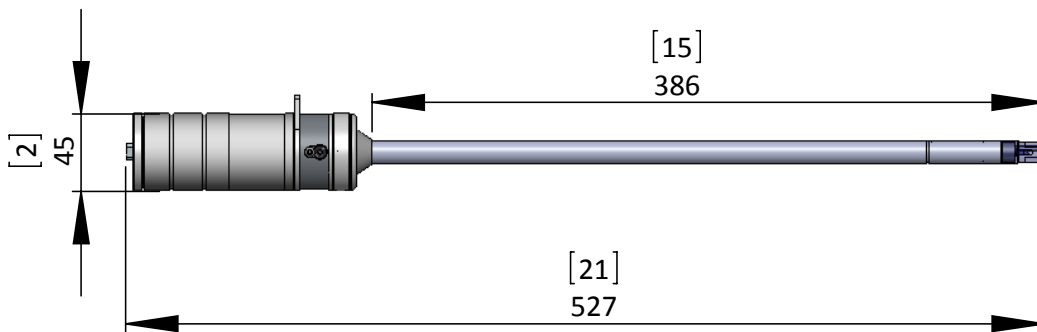

## Order codes

### Flow meters

VPS.R200.P4DP.KIT	VPFlowScope dP start kit, for air audits, complete with software
VPS.R200.P4DP.D11	VPFlowScope dP with 2 million point data logger display module, for auditors and permanent installation (stand-alone)
VPS.R150.P400.D10	VPFlowScope with three row display
VPS.R200.P4DP.D2	VPFlowScope dP with connector cap. For Modbus networks

### Other probe lengths

Only available in 400 mm probe length

### Accessories

VPA.5000.005	Cable, M12, 5 pole, for permanent connection
VPA.5001.105	Interface box JB5 with 5 m/ 16.4 ft cable + 12 VDC power supply
VPA.5001.900	Connector cap with M12 socket for VPFlowScope sensor module

## VPS.R200.P4DP flow range table

SCHEDULE 40 STANDARD SEAMLESS CARBON STEEL PIPE							
Size (inch)	DN	ID (inch)	ID (mm)	Min flow (scfm)	Max flow (scfm)	Min flow (m <sup>3</sup> <sub>n</sub> /hr)	Max flow (m <sup>3</sup> <sub>n</sub> /hr)
2	50	2.1	52.5	92	917	156	1,559
3	80	3.1	77.9	202	2,021	343	3,434
4	100	4.0	102.3	348	3,481	591	5,913
6	150	6.1	154.1	790	7,899	1,342	13,420
8	200	8.0	202.7	1,368	13,678	2,324	23,238
10	250	10.2	259.1	2,234	22,341	3,796	37,957
12	300	11.9	303.2	3,060	30,604	5,199	51,994
16	400	15.0	381.0	4,832	48,316	8,209	82,087
20	500	18.8	477.8	7,599	75,994	12,911	129,110

SCHEDULE 10 STANDARD SEAMLESS CARBON STEEL PIPE					
ID (inch)	ID (mm)	Min flow (scfm)	Max flow (scfm)	Min flow (m <sup>3</sup> <sub>n</sub> /hr)	Max flow (m <sup>3</sup> <sub>n</sub> /hr)
2.2	54.8	100	999	170	1,697
3.3	82.8	228	2,282	388	3,877
4.3	108.2	390	3,897	662	6,621
6.4	161.5	868	8,678	1,474	14,743
8.3	211.6	1,490	14,897	2,531	25,309
10.4	264.7	2,332	23,316	3,961	39,612
12.4	314.7	3,296	32,965	5,601	56,006
15.6	396.8	5,242	52,420	8,906	89,058
19.6	496.9	8,219	82,191	13,964	139,638

The ranges apply only to compressed air and nitrogen. Contact us for other gases. The field accuracy of an insertion probe is typically +/- 5% due to installation conditions. Insertion probes may not be used for official compressor testing.



**'The VPFlowScope** is super easy to install and allows me to show customers just how important measuring flow really is'

- Frank Moskowitz, Draw Professional Services





# Get the complete picture!

Measure, monitor and manage your compressed air system to reduce your energy consumption. Our flow meters are used to establish baseline air flows and energy use. VPVision warehouses and analyzes flow data. It becomes the cornerstone of an energy management system for any plant seeking to sustain the energy efficiencies they have achieved.

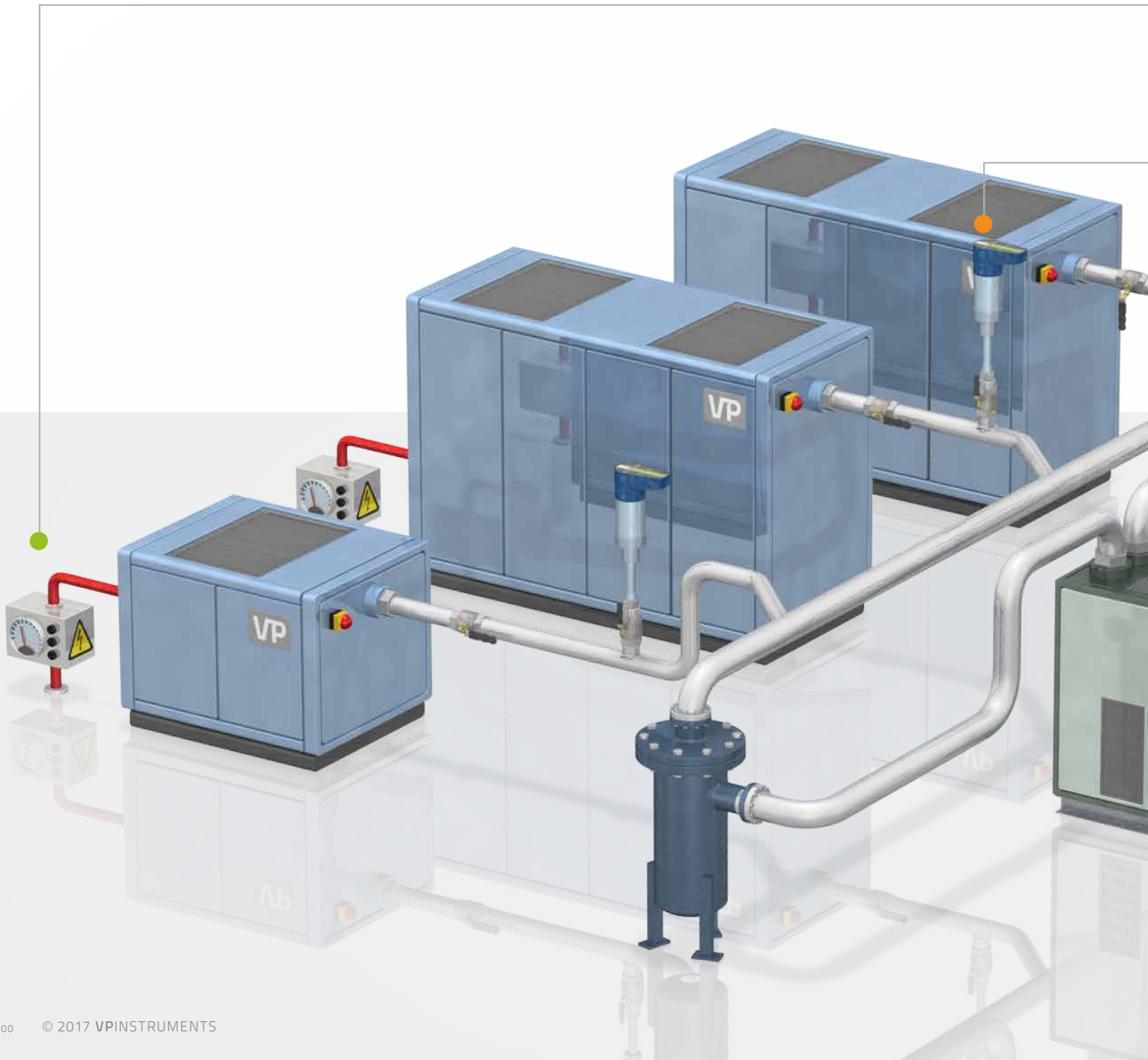



### Monitor efficiency

No more assumptions: We offer total solutions for monitoring the efficiency of your compressors.

### Measure energy loss

Monitor your pressure loss over the entire air treatment and take timely action.

### Get a grip on quality

Monitor dew point to check the performance of your air dryer. Make sure that the air quality meets your standards.

### Monitor demand side

Use VPVision to check where, when and how much air is being used, and allocate costs.



# VPFlowScope® In-line

With the three in one VPFlowScope® in-line, VPIstruments sets the new standard for compressed air measurement. Flow, Pressure and Temperature measured at the same time, at the same point with a single instrument makes measuring child's play. All key performance indicators of your compressed air system are finally measured together, the way they should be. It's time to reveal and unleash the real savings potential of your factory.

The VPFlowScope® in-line is your best choice to move forward with creating better efficiency levels in your compressed air and technical gas systems. Now you have an instrument that provides you with flow, pressure and temperature measurement in one single device, for point of use applications.

Again, the VPFlowScope® in-line shows you when, where and how much you can save. The advanced features of the VP-FlowScope® in-line complete the product family and it is just as easily integratable as the VPFlowScope® probe.

## General applications

- > Point of use measurement
- > Cost allocation
- > Sub metering of compressed air
- > Ring networks (bi-directional)
- > Leakage monitoring
- > Consumption metering of Nitrogen, Carbon Dioxide, Argon, Helium or any other dry, non-corrosive and inert gases

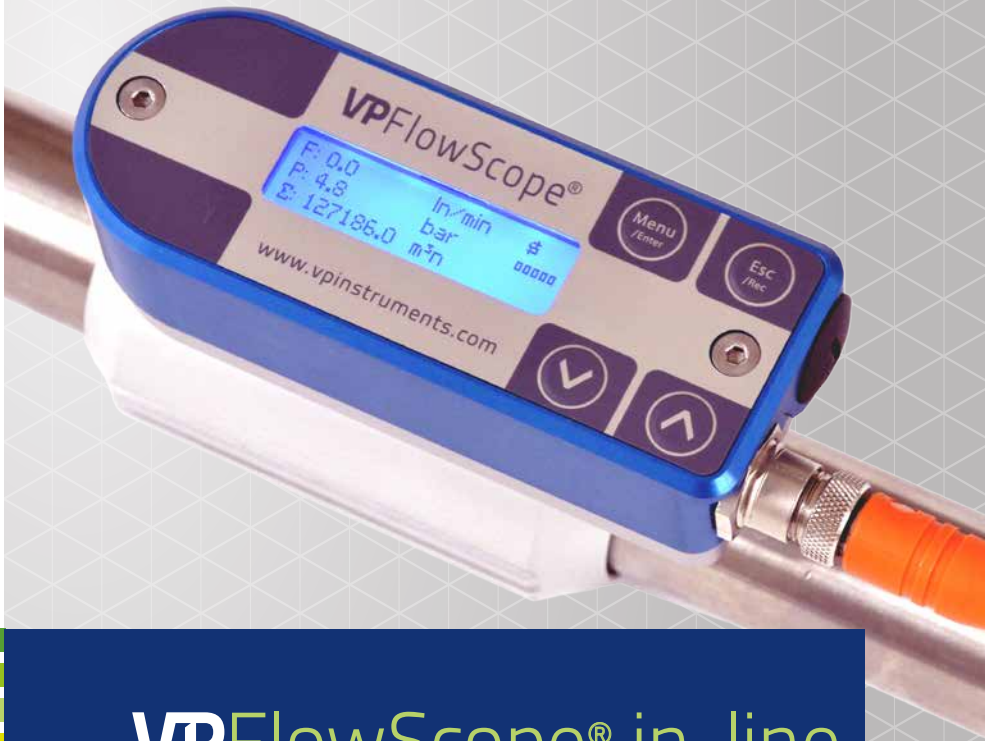

## VPFlowScope® in-line

- > Mass Flow, Pressure & Temperature
- > Bi-directional measurements (optional)
- > 2 million point data logger (optional)

# Specifications

## VPFlowScope® in-line

### Flow Sensor

Measuring principle Thermabridge mass flow sensor

### Range and diameter

	Flow (SI)	Flow (IM)	Size
VPS.R080.M050	0.2 ... 80 (m <sup>3</sup> <sub>n</sub> /hr)	0.1 ... 45 SCFM	0.5 inch
VPS.R250.M100	0.9 ... 250 (m <sup>3</sup> <sub>n</sub> /hr)	0.5 ... 145 SCFM	1 inch
VPS.R01K.M200	3.6 ... 1000 (m <sup>3</sup> <sub>n</sub> /hr)	2.2 ... 580 SCFM	2 inch

Reference conditions 0° C, 1013.25 mbar | 32° F, 14.65 psi

Gases Compressed air, Nitrogen, or any other inert, non condensing gases

### Sensors

	Range (SI)	Range (IM)
Flow	Thermabridge mass flow sensor	
Accuracy	0,5% FSS with calibration report under calibration conditions with air 5% FSS without calibration report	
Pressure PN16	0 ... 16 bar gauge	0 ... 250 psi gauge
Pressure PN35	0 ... 35 bar gauge	0 ... 500 psi gauge
Accuracy	± 1.5% FSS (0 ... 60°C)	± 1.5% FSS (32 ... 140°F)
Temperature	0 ... 60° C	32 ... 140° F
Accuracy	± 1° (from 10 mn/sec and up) (At zero flow conditions, temperature reading increases due to self-heating by the flow sensor)	

### Display

Technology	LCD, 3 line display
Memory (optional)	2 million points data logger

### Features

### Data outputs

Analog	4 .. 20 mA or pulse, selectable via installation software
Serial IO	Modbus RTU
USB	Mini USB interface for configuration (display version only)

### Mechanical

	Size	Weight
VPS.R080.M050	135 mm x 49 mm x 85 mm   5.31" x 1.93" x 3.35"	0.7 Kg   1.54 lbs
VPS.R250.M100	135 mm x 54 mm x 91 mm   5.31" x 2.12" x 3.58"	0.7 Kg   1.54 lbs
VPS.R01K.M200	150 mm x 88 mm x 124 mm   5.9" x 3.46" x 4.88"	1.6 Kg   3.53 lbs
IP grade	IP65   NEMA 4 when mated to connector, at room temperature; direct rain and sunlight should be avoided. Extreme temperature fluctuations may affect the IP grade over time.	
Ambient temperature	0 ... 60° C   32 ... 140° F	

### Total length with pipes

	Length	Pipe weight
0.5"	304 mm   12"	0.3 Kg   0.66 lbs
1"	501 mm   19.7"	1.0 Kg   2.20 lbs
2"	750 mm   29.5"	3.2 Kg   7.04 lbs

### Electrical

Connection type	M12, 5 pin connector, female, and optional USB mini connector
Power supply	12 ... 24 VDC ± 10% CLASS 2
Power consumption	2,4 Watt (no flow) 4,8 Watt (full flow) +/- 10% 100 mA (no flow). 200 mA (full flow) +/- 10% @24VDC
CE	EN 61326-1(2006) Class A, EN61000-6-1 (2007)

# Smart, simple and complete.

The VPFlowScope® in-line provides not just one, but all required parameters: flow, pressure, and temperature are measured at the same time, at the same point. It also features an optional built-in 2 Million point data logger. This means: no more hassle with external loggers, just plug in, press record and go!



Order codes	Flow Range	Option	Display	Option	Connector
VPS.R080.M050	0.2 ... 80 (m <sup>3</sup> <sub>n</sub> /hr)	D0	no display	C5	5 pin M12
VPS.R250.M100	0.9 ... 250 (m <sup>3</sup> <sub>n</sub> /hr)	D10	Display	C8	8 pin M12, for remote display*
VPS.R01K.M200	3.6 ... 1000 (m <sup>3</sup> <sub>n</sub> /hr)	D11	Display + 2 M point logger	* Only available for VPFlowScope in-line D0	
<b>Basic Features</b>		<b>Display features</b>		<b>Connector types</b>	
Thermabridge Flow sensor Pressure and temperature sensor 4...20 mA or Pulse output (switchable) RS485 Modbus RTU		3 Line display Multi-session datalogger Keypad for configuration USB Cable included* *not available for VPFlowScope D0		M12, 5 pin for standard application M12, 8 pin for remote display function	
<b>Calibration options</b>					
VPA.0009.001 VPA.5000.911		ISO Calibration report ± 0,5 % FSS Bi-directional measurement option			
<b>Tubing kits</b>					
VPA.1200.005 VPA.1200.010 VPA.1200.020		0,5 inch, in- and outlet tubes 1 inch, in- and outlet tubes 2 inch, in- and outlet tubes			
<b>Accessories</b>		<b>D0, D10 and 11 version</b>			
VPA.5000.005 VPA.5000.010 VPA.0000.200		Cable, 5m / 16.4 ft with M12 5pin connector on one side, open wires on other side. Cable, 10m / 32.9 ft with M12 5pin connector on one side, open wires on other side. Power supply (12V, 5pin, VPFlowScope)			
<b>Accessories</b>		<b>D0 version only</b>			
VPA.5001.205		Interface box JB5 with 5m/16.4 ft cable + 12 VDC power supply, includes USB converter			
<b>VPStudio software</b>					
SFT.5003.300		Licensed edition VPS&VPT			

# Dew point sensors

Maintaining the dew point of your air or gas system will prolong the lifetime of your equipment. Permanent monitoring enables you to detect and prevent problems on time.

VPInstruments' dew point transmitters are designed for ease of use, incorporating all the features needed to make installation and operation as simple as possible. The calibrated transmitters can be instantly incorporated into VPVision, or they can be connected to your air or gas management and control system.



### Product highlights

- > 2-wire loop powered connection
- > Dew point or ppm moisture content
- > IP66 (NEMA 4X)
- > Excellent sensor protection
- > Fast response time

APPLICATION	DEW POINT	CONNECTION	ORDER CODES
extreme dry air moderate dry air	-100 ... +20°C   -148 ... 68°F -40 ... +60°C   -40 ... 140 °F	4 ... 20 mA 2 wire 4 ... 20 mA 3 wire	VPA.8000.1003 VPA.8000.1013

Specifications	VPA.8000.1003	VPA.8000.1013
<b>Performance</b>		
Measurement range	-100 ... +20°C   -148 ... 68 °F dew point	-40 ... +60°C   -40 ... 140 °F dew point
Accuracy (dew point):	±2°C   ±3.6 °F dew point	±2°C   ±3.6 °F dew point
Response time	5 mins to T95 (dry to wet)	<10 sec typical (90% of the step change)
<b>Electrical output/input</b>		
Output signal	4 ... 20 mA (2-wire) current source, configurable over the entire range	4 ... 20mA (3-wire)
Supply voltage	12-28VDC	8-30VDC
Current consumption	20mA max	9mA + load current
Supply voltage influence	±0.005% RH/V	±0.005 % RH/V
<b>Operating conditions</b>		
Operating humidity	0 ... 100% RH	0 ... 95% RH (non-condensing)
Operating temperature	-40 ... +60°C   -40 ... 140 °F	-30 ... +70°C   -22 ... + 158 °F
Operating pressure	450 barg max.	20 barg maximum
Temperature coefficient	Temperature compensated across operating temperature range	±0.05 %/°C
<b>Mechanical specifications</b>		
Ingress protection	IP65   NEMA 4	IP65   NEMA 4
Housing material	Stainless steel	Nickel-coated brass
Dimensions	L=132mm x ø27mm   5,2 x 1,1"	L=85mm, ø24mm (max)   3,3 x 0,9"
Filter	HDPE Guard <10 µm	HDPE front filter
Process connection	5/8" - 18 UNF	G1/2 (1/2" BSP)
Connection	DIN connector	2 m   6.5 Feet



# Current sensors

The VPLog-i measures AC currents up to 3200A (true-RMS on a single phase power cable). The VPLog-i is very easy to use: just wrap around one of the three phases and close the snap fitting. It offers the best solution for your mobile power measurements. The VPLog-i is the only sensor on the market that offers both 4 ... 20mA and pulse outputs.

## Product highlights

- > Very easy and quick installation
- > Plug and play
- > For fixed and mobile measurements
- > Both 4 ... 20mA and pulse output
- > Loop powered

## Usage

Easy does it: Just open the sensor and wrap around the power cable you want to measure. The LED on the device blinks when the VPLog-i is powered. The rate at which it blinks is proportional to the output current. You can use one of the two outputs to get accurate measurement results.



## Outputs

4 ... 20mA: The analogue output is proportional to the measured input and ranges from 4 to 20mA.

Pulse: The pulse output generates a pulse frequency proportional to the current measured. This allows the VPLog-i to be used as a simple power meter.

## Application examples:

- > Power consumption of compressors
- > General purpose power measurement
- > Electricity sub metering

The current sensor measures the input power of your compressor's electric motor. When combined with a flow meter, it can be used to determine the actual efficiency of the compressor.



## Specifications

Accuracy	+/- 1% full scale.
Power supply	6 ... 30 Vdc
Power consumption	4 ... 20mA
Current input	100 ... 3200 A-rms (50Hz current)
Max Voltage	Insulated cables only! On open bus bars max 300 Volt
Pulse rate	0 ... 2.66 Hz
Coil length	170 mm   6.7", 250 mm   9.8", 350 mm   13.8"
Coil diameter	7 mm   0.28"
Coil bend radius	35 mm   1.38"
Housing W x H x D	26.7 x 41.4 x 13.6 mm   1.1 x 1.6 x 0.6 inch
Operation temperature range	-20 ... 70°C   -4 ... 158 °F
Operational relative humidity	Max 95%, non condensing

ORDER CODES	MAX CURRENT - RMS	FREQUENCY	PULSES/AH	COIL LENGTH (MM)	INCH
VPA.8000.2100	100 A	50/60 Hz	10	250	9.84
VPA.8000.2200	200 A		10	250	9.84
VPA.8000.2400	400 A		10	250	9.84
VPA.8000.2800	800 A		10	250	9.84
VPA.8000.21K5	1500 A		1	250	9.84



## Monitor

'If you monitor, you know when, where and how much you can save'

# VPFlowTerminal



The VPFlowTerminal is a plug & play wall mount display with built-in power supply and 2 million point data logger. The VPFlowTerminal has five sensor inputs: one input for a VPFlowScope in-line or VPFlowScope insertion meter, and four generic analog inputs. It can record up to 8 channels. This makes the collection and analysis of your compressed air data easier and quicker!

## Product highlights

- > Two million point data logger
- > VPFlowScope input
- > 4 analog input channels

## Applications

**Efficiency:** monitoring the efficiency of your compressor system. Measure with the VPFlowScope in the main pipe line of your system and use 4 power meters to measure the power consumption of each compressor.

**Air audits:** the VPFlowTerminal can be used for air audits since you collect all data within one data logger. This makes the data collection, read out and analysis very convenient. Total package: Measure flow together with dew point, pressure and power consumption.

## Order codes

### For VPFlowTerminal

VPT.5110.000

VPFlowTerminal for VPFlowScope. Including display with built-in data logger. Pre-mounted connector for VPFlowScope. Built-in power supply. Includes black connector cap with cable 10m/32.9ft, 4 Analogue inputs for VPFlowTerminal. Data will be logged simultaneously. Configuration and read out with VPStudio.

# Technical drawings

VPT.5110.00X

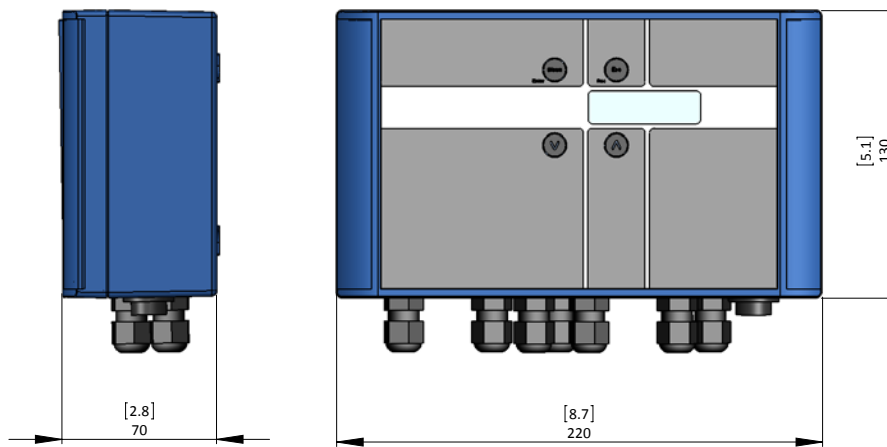

## Specifications

### VPFlowTerminal

Input voltage	100 ... 240 Vac mains (pre-wired)
Housing type	Painted Aluminum IP65   NEMA 4
Display	Liquid Crystal (LCD), 3 lines
Back light	Blue with auto power save.
Data logger	Two million point data logger
Signal inputs	VPFlowScope + 4 optional 4 ... 20 mA sensors (non - isolated, loop powered)
Sensor power supply	24 VDC
Maximum sensor current	4 x 25 mA for analog sensors, 1 x 150 mA for VPFlowScope
Data outputs	USB for configuration and data retrieval
Ethernet interface	Modbus / TCP port
Basic configuration	Via key pad
Flow meter connection	M12, 8 pin
Additional connections	Cable glands for analog inputs, Ethernet connection.
Dimensions	l x b x h = 230 x 130 x 75 mm.   9.1 x 5.1 x 2.95"
Weight	1.6 kG   3.53 Lbs



# VPStudio Software

With VPStudio, you can configure all VPInstruments products, view real time measurements and retrieve data log sessions. VPStudio enables you to view data in any unit both SI and Imperial. You can schedule your data log session, set logging intervals and adjust flow meter parameters. VPStudio communicates via your PC's USB port.

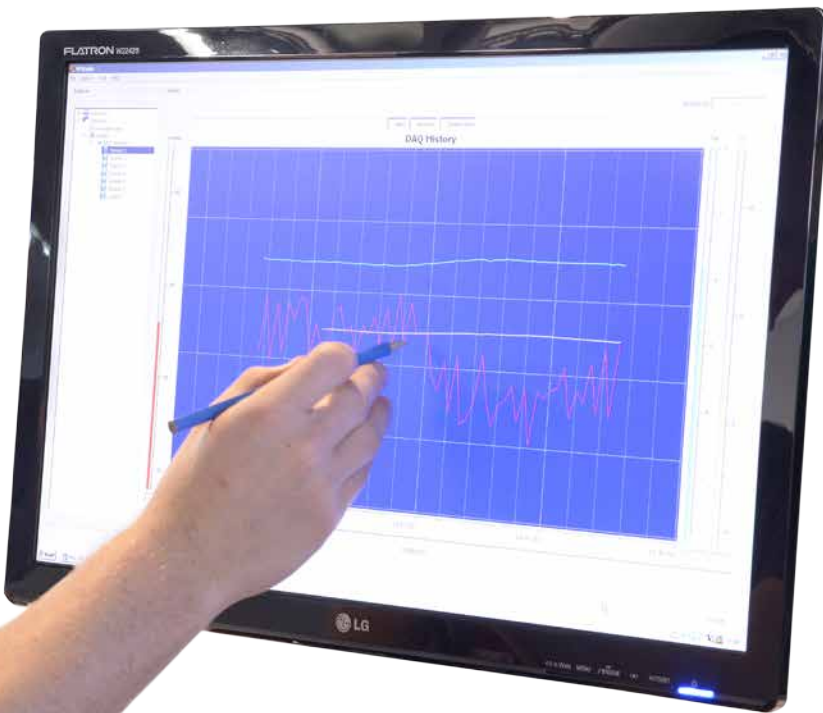

## Applications

- > As a configuration tool for all VPInstruments products
- > To read saved data log sessions
- > To extract recorded data to CSV files
- > Optional real time data logging on PC which can be saved as CSV

FUNCTIONS	FREE EDITION <sup>1</sup>	ADVANCED VPFLOWMATE	ADVANCED VPFLOWSCOPE	FULL/ EVALUATION <sup>2</sup>
Order codes		SFT.5003.200	SFT.5003.300	SFT.5003.400
Flowmeter configuration (all types)	√	√	√	√
Download data log sessions	√	√	√	√
Data Export	√	√	√	√
Real Time measurement VPFlowScope/VPFlowTerminal			√	√
Real time measurement VPFlowMate		√		√
Scheduler for display/ VPFlowTerminal			√	√
CSV Studio		√	√	√

<sup>1</sup> Free edition: basic configuration only

<sup>2</sup> Evaluation version is valid for one month from date of activation



**Manage** 'Beware of little expenses; a small leak will sink a great ship'

- Ben Franklin



## VPVision

VPVision offers you the complete monitoring solution for compressed air and technical gases. It makes energy savings easy, quick and rewarding. Using the latest web technology, VPVision enables you to view data anywhere, anytime. VPVision analyzes flow data and makes your savings potential transparent.

VPVision can be expanded to receive and consolidate data such as electric demand (compressor kW) and dew point. VPVision can also be fully integrated into a plant's existing SCADA system and linked to the Internet to allow access by designated company staff from anywhere.

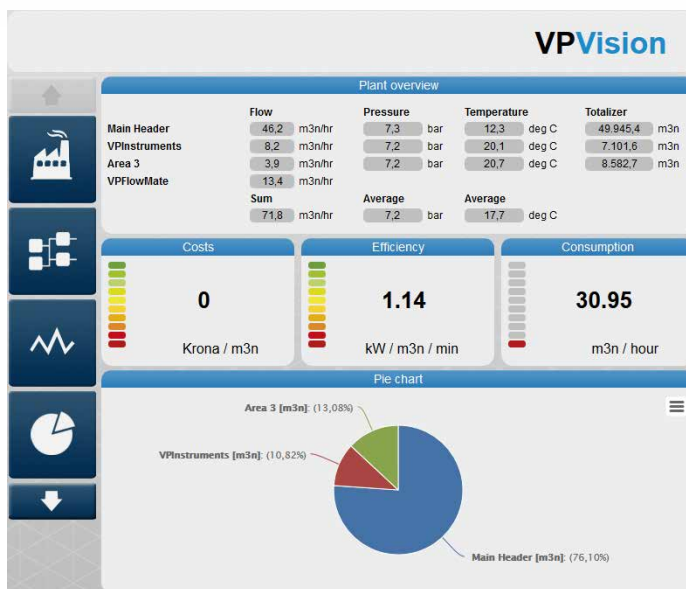

### With VPVision you can:

- > Maintain your efficiency
- > Allocate costs
- > Track and monitor leak level
- > Generate automated reports in PDF
- > Expand and adapt the system
- > Follow your system via iPad®, Smart PH, tablet and web browser
- > Centralize benchmark different plants on different locations.
- > Track Maintenance need points

### Product highlights

- > Web based interface
- > Built in reporting tools
- > Early alert on leakage
- > Customizable screens
- > Interactive P&ID
- > SQL connections
- > Direct insight in costs
- > Based on standardized hardware

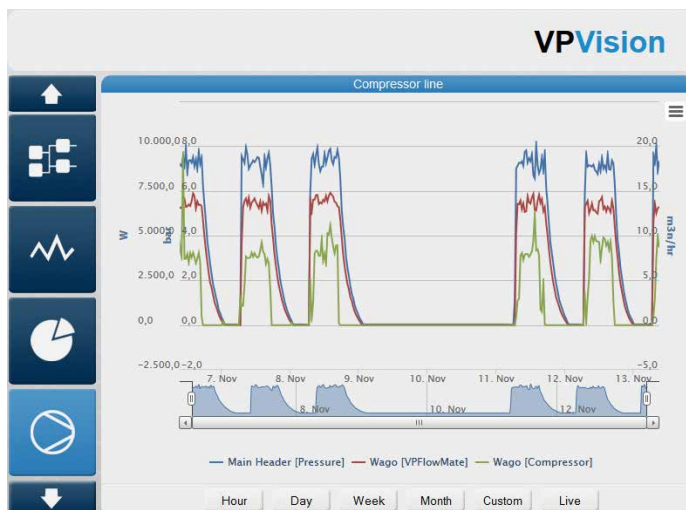

# VPVision project examples

## Food production

In a Kikkoman soy sauce factory, a VPVision system has been installed to monitor the demand side of the compressed air system. All individual cost centers are monitored by flow meters. VPVision logs all data and provides real-time feedback on actual use.

## Cookie factory

Bolletje, a Dutch manufacturer of cookies and bakery products invested in a VPVision system to allocate costs to various production lines. The system is linked to 3rd party energy monitoring and reporting software. VPVision was part of a compressed air optimization project, which resulted in a cost reduction of 25%.

## Steel factory

In a large steel plant, VPVision is used to monitor 10 compressor stations. It guards a savings program which exceeds 250,000 Euro per annum, and helps to make the right decision on where to save next.

## Metal parts production

Astrum, a leading manufacturer of casted steel parts in the UK invested in a VPVision system to monitor the overall compressed air supply and demand. The VPVision system is part of a complete compressed air system re-design, with an ROI of less than 3 years.

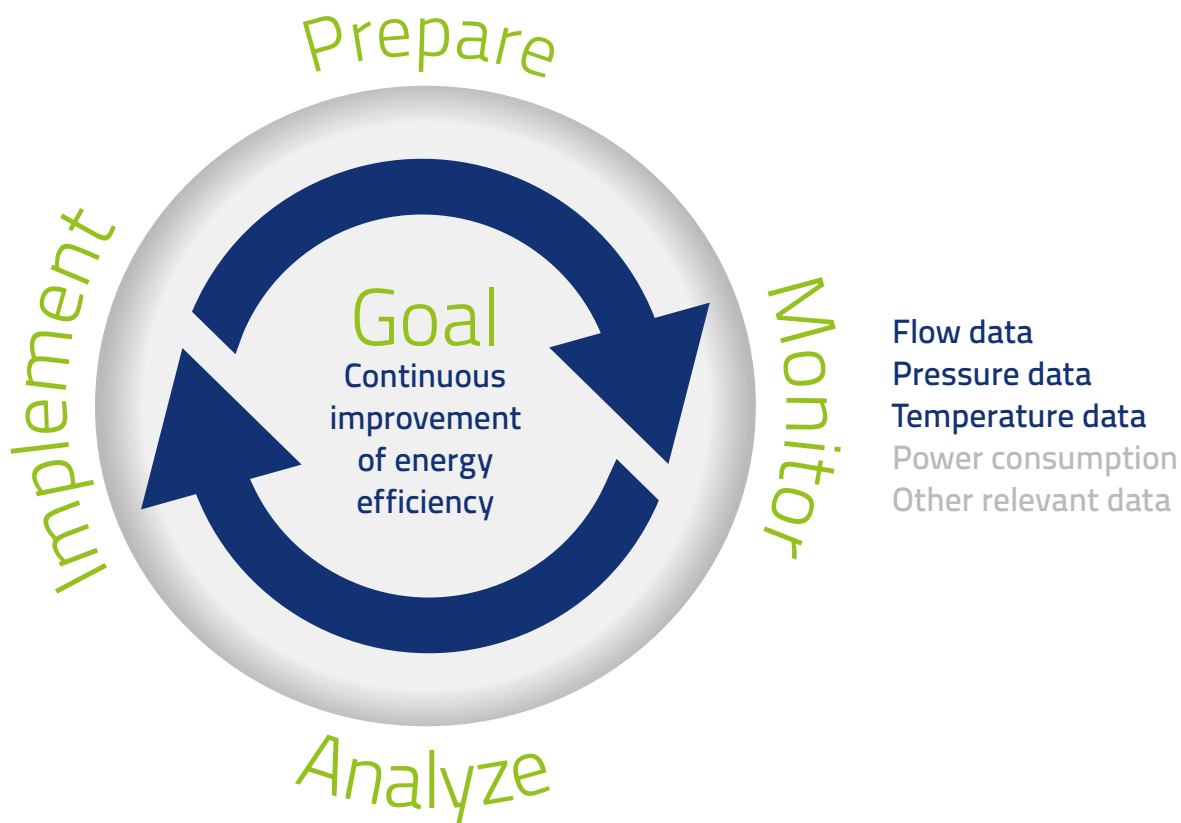



# Part numbers overview

The following table provides an overview of the available hardware and software. Please use the project preparation form, which can be supplied by your local distributor. This form is used to determine the complete list of required hardware and software for your project.

Order codes	
VPV.6001.M00	VPVision M. Main unit, with VPVision software, database, webserver, built-in power supply pre configured to display up to 8 VPFlowScope sensors. Can be read out on your own PDA, Tablet, PC or touch screen via the network. Powder coated steel enclosure, IP65.
VPV.HMI2.010 (optional)	10" panel mount touchscreen.
VPA.5030.020	Modbus junction box (IP65.) Add one per VPFlowScope for a Modbus RS485 multidrop network.
VPA.5030.011	Modbus extension module with power supply. Din rail mounted power supply module built into IP65 plastic enclosure. With this module you can supply power to another 8 VPFlowScopes in a daisy chain.
VPA.5030.111	Power supply module with Ethernet converter for 8 additional VPFlowScope sensors. Built in IP65 plastic enclosure. With this converter you can transfer Modbus signals over Ethernet to the VPVision M unit, or an existing building management system.
VPA.5030.211	Analogue to Ethernet converter with power supply. Power supply module with 4..20 mA analogue inputs. Built in IP65 plastic enclosure. With this converter you can transfer analogue signals over Ethernet to the VPVision M unit or an existing building management system.
VPA.5030.311	Analogue and Modbus to Ethernet converter with power supply. Power supply module with an analogue and a Modbus converter, to combine analog sensors with up to 8 VPFlowScope sensors. Built in IP65 plastic enclosure. With this converter you can transfer Analogue and Modbus signals over Ethernet to the VPVision M unit or an existing building management system.
SFT.6001.M01	Additional measurement points implemented in the software. The software is designed to display up to 8 flow meters in a convenient way. Above 8, channels are grouped together. Ask us for a project specific quotation in this case.
SFT.6001.M05	Additional visualiation P&ID : overview of your compressed air system
SFT.6001.M07	Alarms module. With the alarm module, you can pre-set trigger levels, and e-mail an alarm message if signals are out of bounds. The ideal tool for maintenance management and leakage alerts.
SFT.6001.M10	Virtual channel sensor extension (paid per channel). Add, subtract, multiply, avarage sensor values into a new unit display.
SFT.6001.M11	SQL data base connection to transfer data to an overlay or parent system. Data available every hour in 15 minute or hourly averaged blocks.



# Install

'It all begins with proper installation'

## Hot tap drill

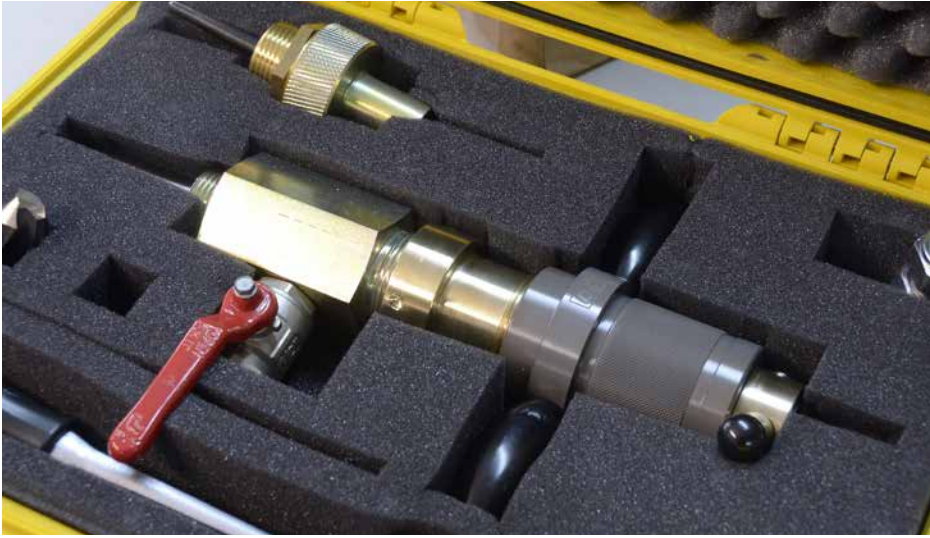

### Specifications

#### VPA.8001.1002

Max pressure	10 bar   145 psi, higher pressure ratings on request
Drill shaft diameter	16 mm   0.6 inch
Drill shaft length	345 mm   14 inch
Drill diameter	17 mm x M10   0.7 inch x M10

The hot tap drill is the universal tool to install your insertion flow meter in any compressed air system. In only 30 minutes you can drill a hole and install your flow meter. Using a hot tap saddle and a hot tap drill, you can create a new installation point without depressurizing your installation. Compared to low-cost electrical hot tap drills, which are prone to jamming and breaking of the drill head, our hot tap drill is safe and easy to operate. See our instruction video for details.

**Note:** Hot tapping is a skilled task. Familiarize yourself with this task. VPInstruments also offers you training to become skilled. Once trained, you will be able to make process connections quickly, safe and economically. The average time to install is only 30 minutes.

#### Features:

- > For application up to 10 bar
- > 1" Hot tap drill size
- > All accessories included
- > Explorer® transport case included

#### Benefits:

- > Make an installation point without taking the pressure off your system
- > Hand operated: no power tool needed on-site
- > Safe and easy operation
- > Versatile: For stainless and carbon steel

# Thickness gauge

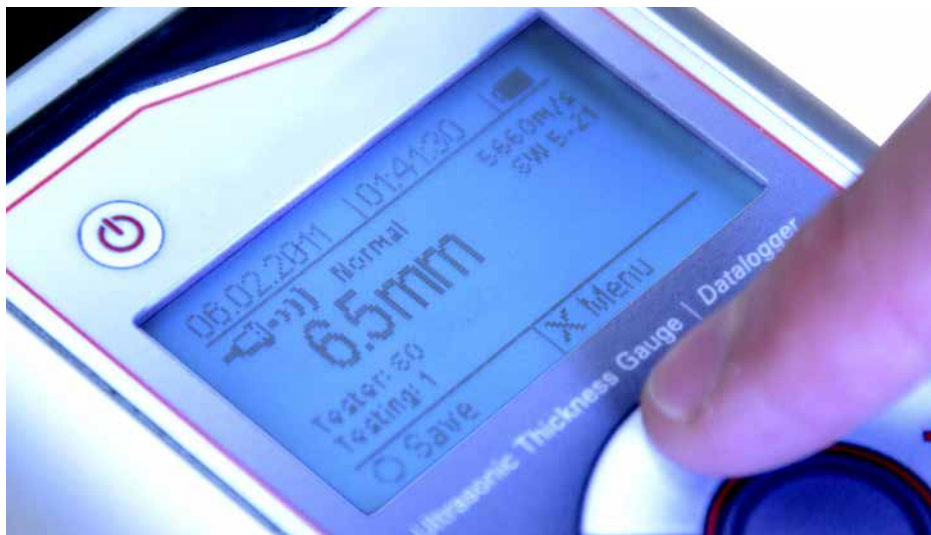

The ultrasonic thickness gauge is used to measure wall thickness, which is key information to calculate the exact inner pipe diameter.

It is important to know the exact wall thickness, especially in smaller pipes. In the table below, we show the influence of 1 mm | 0.04 inch error on your flow meter reading, for various pipe diameters.

### Features:

- > Capable of performing measurements on a wide range of materials, including metals, plastic, ceramics, and glass
- > High accuracy
- > Integrated data logger
- > One universal probe for a wide measuring range
- > Includes transport case

Disclaimer: The VP Thickness Gauge is only to be used to measure wall thickness, not integrity or composition of the material.



DIAMETER (MM)	~INCH	ERROR (%)
50	2	4
100	4	2
150	6	1.30
200	8	1
250	10	0.80
300	12	0.70

## Specifications

### VPA.8001.1001

Measuring range (steel)	0.6 ... 400 mm   0.02 ... 16 inch (depending on probe type)
Accuracy	0.1 mm   4/1000"
Working temperature	-10 ... 50°C   14 ... 122 °F
Display	Back-lit display (128 x 64 pixel)
Connections	USB, probe
Power supply	2 x LR6 / AA - primary cell
Operating time	40 hours (backlight off)
Data logger	Max. 10,000 readings
Protection class Device	IP65   NEMA 4
Probe	IP67   NEMA 6P
Software	Software included, Windows



# Leak Detector



The VP Leak Detector is a practical tool for any leak detection program. Simple to use - find compressed air leaks and prevent machinery failure with this unique instrument.

Leak detectors are a beneficial addition to mass flow meters for your leakage management program. The two instruments together make your leakage management system efficient. Measure and manage your ROI when repairing leaks. Use your flow meters to establish a leakage level before you repair the leaks and report the savings after.

Ultrasound is generated due to friction caused by the flow of gases, liquids and solids in pipes and leakages. These ultrasonic signals are recorded by the VP Leak Detector, their intensity is shown on the display screen and made audible through speakers or headphones.

## Order codes

VPA.8000.1009	Leak detector basic
VPA.8000.1010	Leak detector for leaks and bearings, basic
VPA.8000.1011	Leak detector with data logger - for leaks and bearings

## Specifications

Function	Multifunctional detector
Display	Graphical display with background lighting and Menu control
Connections	Ultrasonic sensor, temperature sensor, headphone USB interface (USB 2.0)
Keyboard	8 function digits
Ultrasonic sensor	Internal and external
External sensors	Sound level (noise level) dBA
Data logger	Memory for 250 single- and longtime tests with max. 21.000 datasets
Measuring Range	-10 dB $\mu$ V to +70 dB $\mu$ V *1)
Accuracy	$\pm$ 0.5 dB $\mu$ V
Measuring resolution	0.1 dB $\mu$ V
Lowest signal level	-5 dB $\mu$ V typical
Band width	(-3 dB) 2 kHz
Frequency range	40 kHz (20-60 kHz width 2 kHz increments)
Battery pack	Batteries (R6) with a nominal voltage of 1.5V are used
Operating temperature	-10 °C to +60 °C
Temperature measurement range	0 °C to 800 °C
Storage temperature	-20 °C to +60 °C
Housing	Shock-proof plastic with wiping resistant keyboard (foil)
Weight	Approx. 650 g
Dimensions	190 x 110 x 85 mm

### Application examples:

- > Compressed Air Leak Detection
- > Pressure and Vacuum Leak Detection
- > Exhaust system leaks
- > Tanks, pipes, Leak testing
- > Electrical Inspection

# Savings tips

## 1. Shut off sections and machines that you do not use

A simple manual or motorized valve can save you thousands of euros/dollars. Make sure that air is not lost through leaks or machines standing in idle mode. Flow meters help to determine to which sections air is flowing.

## 2. Breathe cool, fresh and clean air

A compressor converts 90% of its power into heat. The compressor room heats up, while a compressor uses less energy to compress cold air. 3°C cooler air, already results in 1% energy savings.

## 3. Invest in an efficient control system

Have insight in your compressed air usage profile, so you can optimize your compressor control system. Ask an air audit specialist to perform an air audit, and make an improvement plan based upon the results.

## 4. Think about the required air quality

Clean compressed air is important for the life span of your compressed air installation. Choose the right quality carefully for specific processes whenever possible, as higher air quality results in higher energy costs.

## 5. Reduce offload hours

Electricity consumption of a compressor in offload stage costs 10-35% of the consumption during load hours. At >80% use of the capacity, the offload-load control is considered efficient. Choose the right control system.

## 6. Manage your leakage

In general there is 20-40% of leakage in a compressed air installation. VPVision can be used as a global leakage management system and helps you to rank the leaks on savings potential. Invest in an ultrasound leak detector to find the leaks.

## 7. Balance your system

Is your compressor oversized? In some applications the compressor is bigger than necessary, for instance after changes in the production process. The payback time of the investment in a smaller compressor is often short.

## 8. Reduce the pressure

Every bar pressure reduction gives an instant win of 7% on your energy consumption. Invest in pressure regulators per production area, use buffer vessels and reduce pressure swings in your network.

## 9. Think of alternative uses

Compressed air is 8 times more expensive than electric power. However compressed air is often used, simply because it is present. The VPFlowScope offers insight in the usage and helps you to select the right solution.

## 10. Choose the right pipe size and material

A proper pipe system is crucial to limit your pressure drop. Iron pipes tend to rust. Too small piping creates pressure loss. Use angular feed-ins on the main header to reduce pressure loss.





**Corporate Headquarters**  
**Van Putten Instruments BV**  
Buitenwatersloot 335  
2614 GS, Delft, The Netherlands

T +3115 2131580  
F +3115 2130669  
Email: [info@vpinstruments.com](mailto:info@vpinstruments.com)

**USA Service Center**

In the USA, please contact our  
authorized service center:  
T +1 614 729 8135  
Email: [info@vpinstruments.com](mailto:info@vpinstruments.com)



**INSTRUMENTS**

© 2012-2015 Van Putten Instruments.

Subject to change without prior notice. All dimensions stated in drawings are indicative. For actual specifications, always consult factory. Our core intellectual property and brand names are protected by Dutch, US and international patents trademark rights, copyrights, and exclusive licenses. All artwork and 3D images in this catalog are copyright material and exclusively made for promotion of VPIstruments. Violators will be prosecuted to the maximum extent possible, by the respective owners. Nothing from this catalog may be re-printed or reused in any way without prior permission. Our general terms and conditions of sale apply on all sales transactions. A copy can be downloaded from our website.

VPinstruments only sell and distribute through authorized dealers  
Your local dealer:

[www.vpinstruments.com](http://www.vpinstruments.com)