

Relief Valve

5.2 to 100 gpm
3045 psi

Features

Balanced piston relief valve.
Optimum pressure control for hydraulic circuit allows operation as a safety valve.

A vent port enables remote control of pressure and use of an unloading circuit.

Specifications

Model No.		Nominal Diameter (Size)	Maximum Working Pressure psi	Maximum Flow Rate gpm	Pressure adjustment range psi	Weight lbs	
Screw Mounting	Gasket Mounting					T Type	G Type
R-T03- A-12 B-12	R-G03- A-E12 B-E12	3/8	3045 P, X (Vent Ports)	5.2	0 to 145 0 to 362	6.6	9.5
R-T03- 1-12 3-12	R-G03- 1-E20 3-E20	3/8		21	0 to 1000 500 to 3000	6.6	9.5
R-T06- 1-E20 3-E20	R-G06- 1-E20 3-E20	3/4		45	0 to 1000 500 to 3000	8.5	11.6
R-T10- 1-E20 3-E20	R-G10- 1-E20 3-E20	1 1/4		100	0 to 1000 500 to 3000	17	17

Note: See the Flow Rate - Low Pressure characteristics for information about items marked with an asterisk (*).

Handling

- To adjust pressure, loosen the lock nut and then rotate the handle clockwise (rightward) to increase pressure or counterclockwise (leftward) to decrease it.
- Make sure that tank port back pressure is no greater than 29 psi. For tank piping of the A and B type pressure adjusting ranges, return directly to the tank without connecting any other piping and eliminate back pressure.
- The pressure adjustment range for the high vent type is 188 psi. Note that R-T/G03 is not a high vent type.
- When using a relief valve as a safety valve, use a pressure override that is higher than the required circuit pressure.
- When using a remote control valve, connect piping to the relief valve port. Pipe capacity can be a source of vibration. Use of thick iron pipe with an inside diameter of no more than .15 in. and a connection length of no more than three meters is recommended.
- Pressure becomes unstable when at slow control flow rates. Use a flow rate of no less than 2.1 gpm for the 03, 06 sizes, and 2.6 gpm for the 10 size. Use

a drain type relief valve in the case of a flow rate that is less than the minimum flow rate.

- Use the following table for specification when a sub plate is required.

Model No.	Pipe Diameter	Weight lbs	Applicable Valve Model
MR-03-E10	3/8	3.5	R-G03-*-12
MR-06-E20	3/4	7.7	R-G06-*-E20
MR-06X-E20	1		
MR-10-E20	1 1/4	18.7	R-G10-*-E20
MR-10X-E20	1 1/2		

- The following are the bundled mounting bolts.

Model No.	Bolt Dimensions	Q'ty	Tightening Torque ft lbs
R-G03-*-12	3/8-16 x 3"	4	33 to 40
R-G06-*-E20	5/8-11 x 3 1/8"	4	140 to 173
R-G10-*-E20	7/8-9 x 4 1/8"	4	272 to 339

Note: For mounting bolts, use grade 8 or equivalent.

Understanding Model Numbers

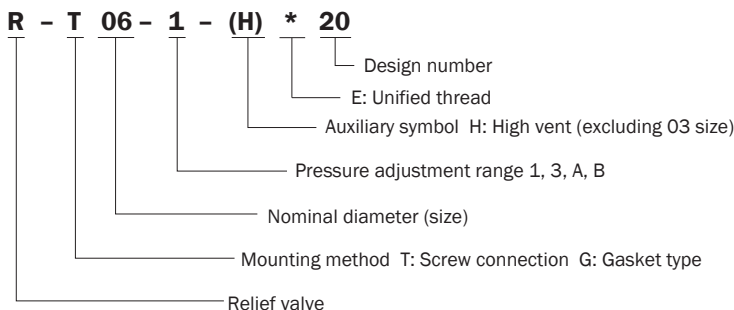

Installation Dimension Drawings

R-T03-*- E12 (Screw Mounting)

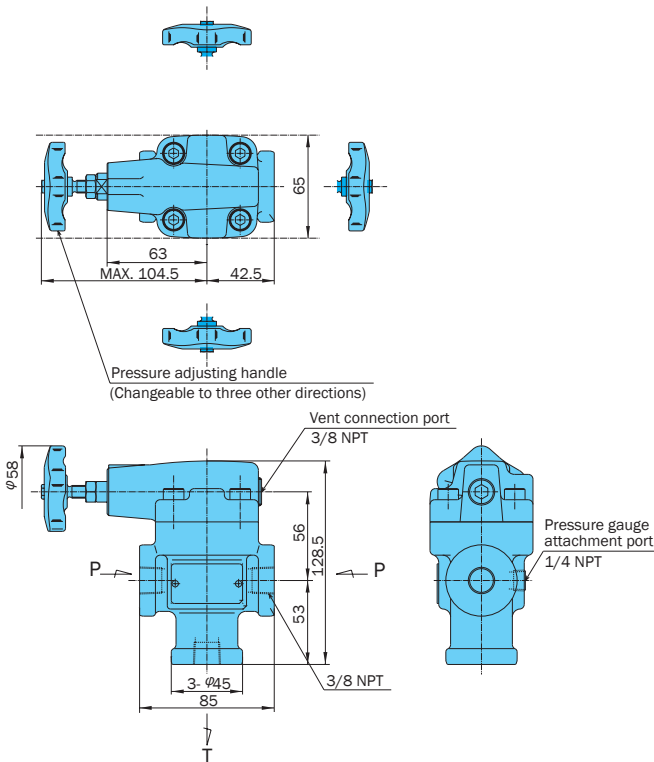

R-G03-*-12 (Gasket Mounting)

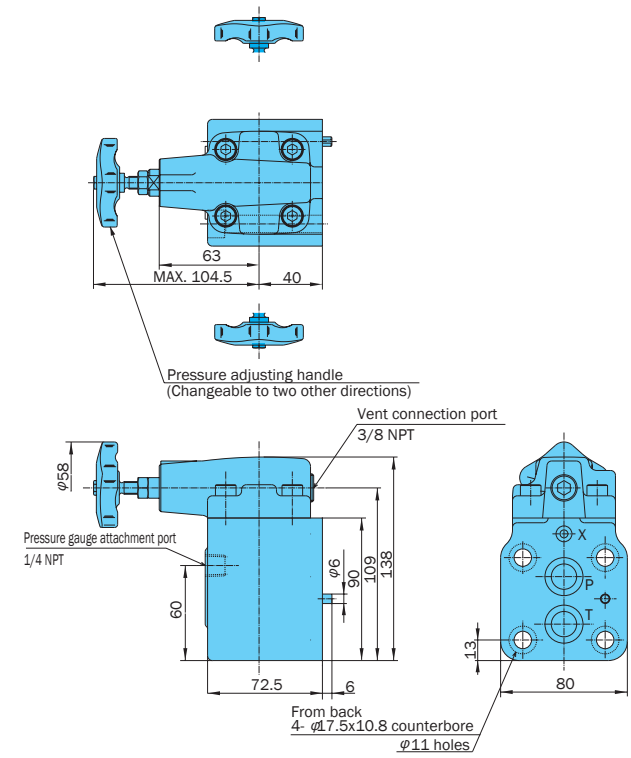

R-T**-*- E20 (Screw Mounting)

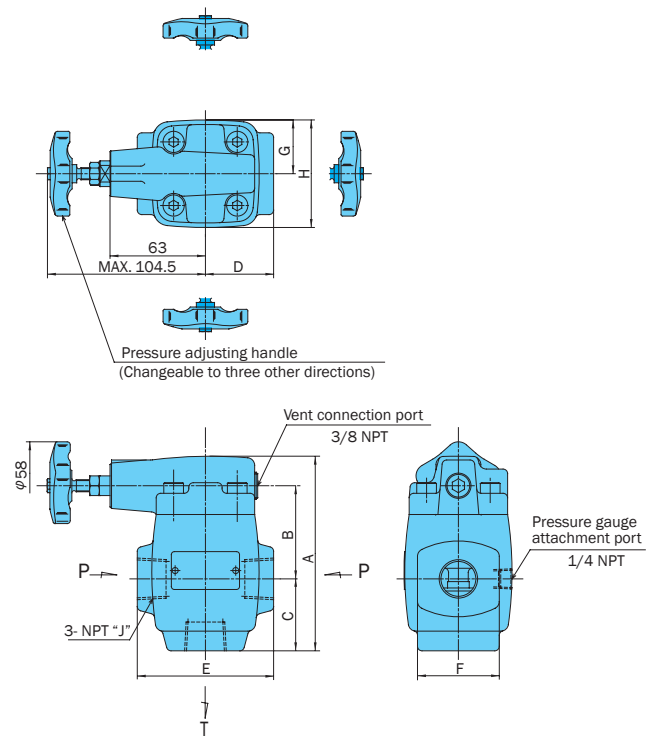

R-G**-*-20 (Gasket Mounting)

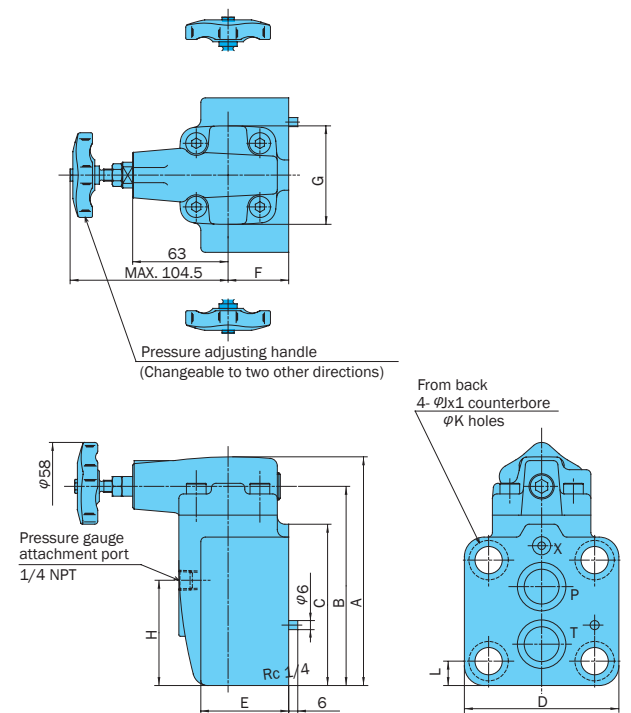

Model No.	A	B	C	D	E	F	G	H	J
R-T06*-20	128.5	61.5	47.5	45	90	54	35.5	71	3/4
R-T10*-20	153.5	72	62	62.5	125	69	47	94	1 1/4

Model No.	A	B	C	D	E	F	G	H	J	K	L
R-G06*-20	151	131.5	106.5	102	58	40	65	69.5	26	18	16.1
R-G10*-20	162.5	143	110	127	80	50	86	70.5	32	22	17.7

Sub Plate MR-03- E10

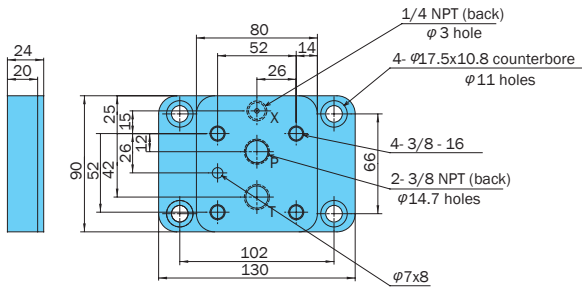

MR-**- E20

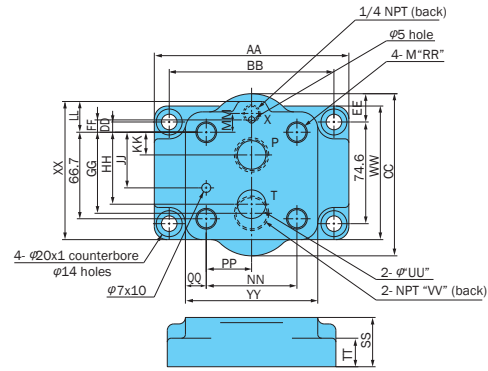

Model No.	Dimensions (mm)																						
	AA	BB	CC	DD	EE	FF	GG	HH	JJ	KK	LL	MM	NN	PP	QQ	RR	SS	TT	UU	VV	WW	XX	YY
MR-06-E20	150	127	125	7.9	21.8	9.5	62.5	55.5	42.9	17.5	23.7	14.5	69.9	34.9	16.1	5/8-11	38	22	22	3/4	98.5	106.5	102
MR-06X-E20																				1			
MR-10-E20	175	152.4	150	6.4	39.2	15.9	71.3	58.7	50.8	14.3	25.6	25.9	92.1	46.1	17.5	7/8-9	55	22	28.5	1 1/4	102.5	110	127
MR-10X-E20																				1 1/2			

Performance Curves

Hydraulic Operating Fluid Viscosity 32 centistokes

Pressure - Flow Rate Characteristics

R-*03-**-E12

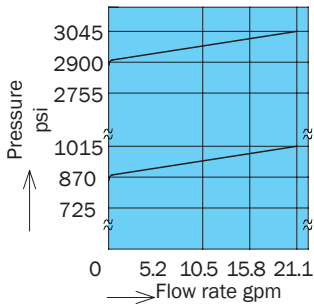

R-*06-**-E20

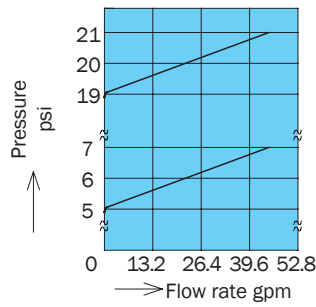

R-*10-**-E20

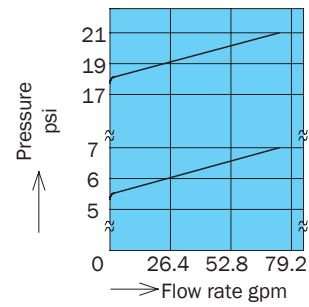

Flow Rate - Minimum Pressure Characteristics

R-*03-^A/_B-E12

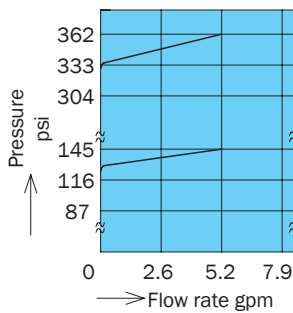

R-*03-^A/_B-E12

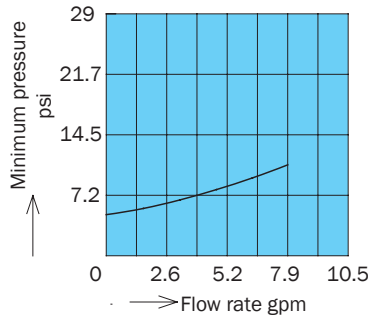

R-*03-1-E12

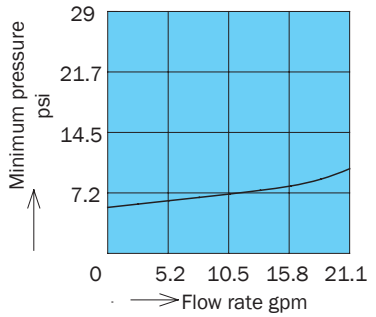

R-*06-1-E20

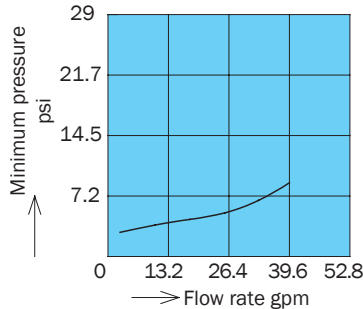

R-*10-1-E20

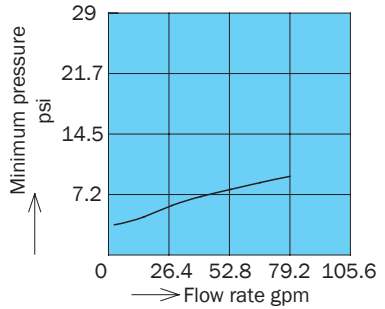

Note: The performance curves do not include T port back pressure.

Installation Dimension Drawings

R-G03- $\frac{A}{B}$ -12

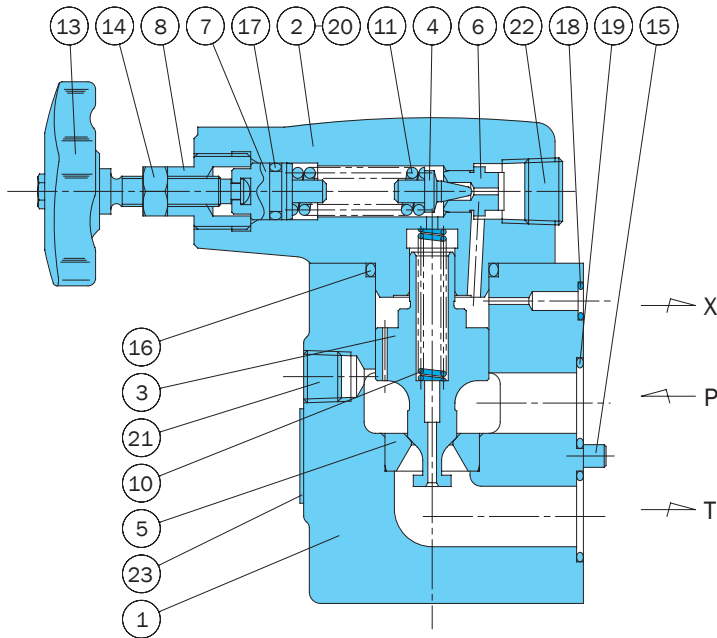

Part No.	Part Name
1	Body
2	Cover
3	Spool
4	Poppet
5	Seat
6	Seat
7	Plunger
8	Retainer
9	Collar
10	Spring
11	Spring
12	Spring
13	Handle
14	Nut
15	Spring pin
16	O-ring
17	O-ring
18	O-ring
19	O-ring
20	Screw
21	Plug
22	Plug
23	Nameplate

Note:
The No. 12 spring is not included when auxiliary symbol H is selected (except with the 03 size).

R-G03- $\frac{1}{3}$ -12 R-G $\frac{06}{10}$ - $\frac{1}{3}$ -20

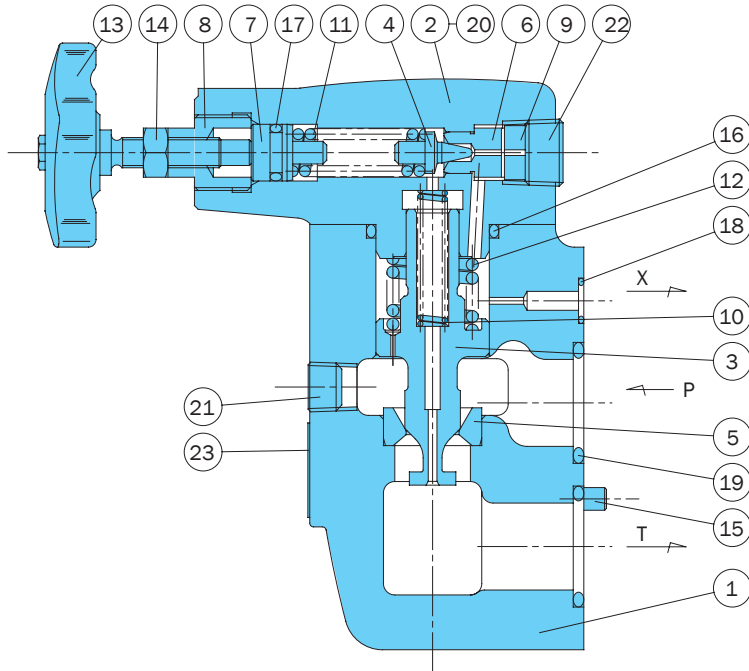

Seal Part List (Kit Model Number RRS-*** (03 size)
RRBS-*** (06, 10 size))

Part No.	Part Name	Type/Part Number						Q'ty
		R-G03-*-12	R-T03-*-12	R-G06-*-20	R-T06-*-20	R-G10-*-20	R-T10-*-20	
16	O-ring	IB-G30	IB-G30	IB-G30	IB-G30	IB-G40	IB-G40	1
17	O-ring	IA-P11	IA-P11	IA-P11	IA-P11	IA-P11	IA-P11	1
18	O-ring	IB-P7	-	IB-P9	-	IB-P9	-	1
19	O-ring	IB-P20	-	IB-P26	-	IB-G35	-	2

Note: O-ring 1A/B-**-** refers to JIS B2401-1A/B.
*** in the kit number is used for specification of the valve size (G03, T06, etc.)

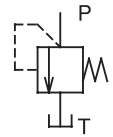

RI Series Relief Valve (ISO Mounting, Balanced Piston Type) 10.5 to 84.5 gpm 5075 psi

Features

Balanced piston relief valve.
Optimum pressure control for hydraulic circuit allows operation as a safety valve.

A vent port enables remote control of pressure and use of an unloading circuit.

Specifications

Model No.	Nominal Diameter (Size)	Maximum Working Pressure psi	Maximum Flow Rate gpm	Pressure adjustment range psi	Weight lbs	Gasket Surface Dimensions
RI-G03-C-20	3/8	5075 P, X Ports	10.5	21 to 507	9.9	ISO 6264-AR-06-2-A
RI-G03-1-20 3 5	3/8		39.6	116 to 1000 507 to 3625 507 to 5075	9.9	
RI-G06-1-20 3 5	3/4		84.5	116 to 1000 507 to 3625 507 to 5075	12.3	ISO 6264-AS-08-2-A

Handling

- To adjust pressure, loosen the lock nut and then rotate the handle clockwise (rightward) to increase pressure or counterclockwise (leftward) to decrease it.
- Make sure that tank port back pressure is no greater than 29 psi.
- For use as a safety valve, use a pressure override that is higher than the required circuit pressure.
- When using a remote control valve, connect piping to the relief valve port. Pipe capacity can cause vibration. Use of thick iron pipe with an inside diameter of no

more than .15" and a connection length of no more than three meters is recommended.

- The following are the bundled mounting bolts.

Model No.	Bolt Dimensions	Q'ty	Tightening Torque ft lbs
RI-G03-*-20	3/8 - 16	4	55 to 70
RI-G06-*-20	5/8 - 11	4	140 to 173

Note: For mounting bolts, use grade 8 or equivalent.

- A small control flow rate can cause pressure instability. Use a control flow rate that is at least 2.1 gpm.

Use a drain type relief valve in the case of a flow rate that is less than the minimum flow rate.

- Use the following table for specification when a sub plate is required.

Model No.	Pipe Diameter	Weight lbs	Applicable Valve Model
MRI-03-E10	3/8	5.7	RI-G03
MRI-03X-E10	1/2		
MRI-06-E10	3/4	7.7	RI-G06
MRI-06X-E10	1		

Understanding Model Numbers

RI - G 06 - 1 - 20

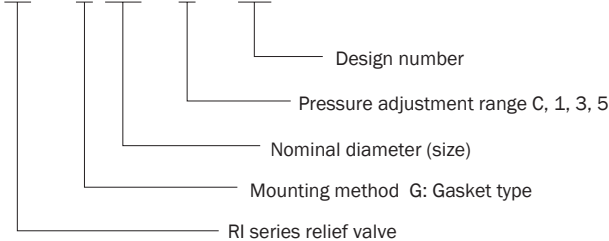

Installation Dimension Drawings

RI-G**-*-20

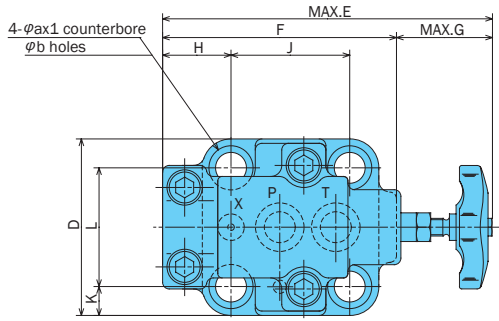

Model No.	A	B	C	D	E	F	G	H	J	K	L	a	b
RI-G03-*-20	132	78	32	80	149.5	106	43.5	31	53.8	13.1	53.8	20	14
RI-G06-*-20	137	83	36	100	158.5	119	39.5	37	66.7	15	70	26	17.5

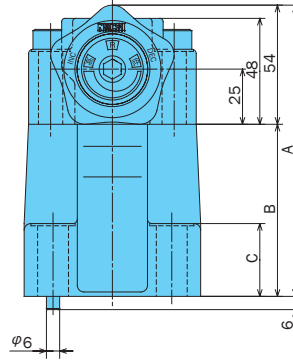
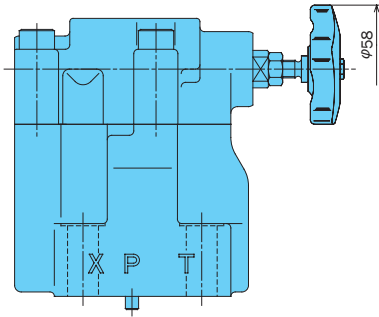

Sub Plate MRI-03-*-E10

(Maximum Operating Pressure: 3625 psi)

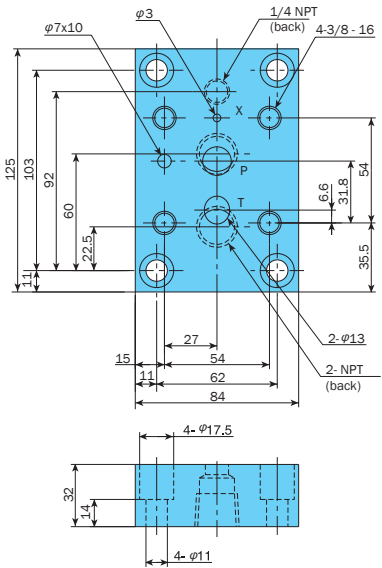

Model No.	A
MRI-03-E10	3/8
MRI-03X-E10	1/2
MRI-06-E10	3/4
MRI-06X-E10	1

Sub Plate MRI-06-*-E10

(Maximum Operating Pressure: 3625 psi)

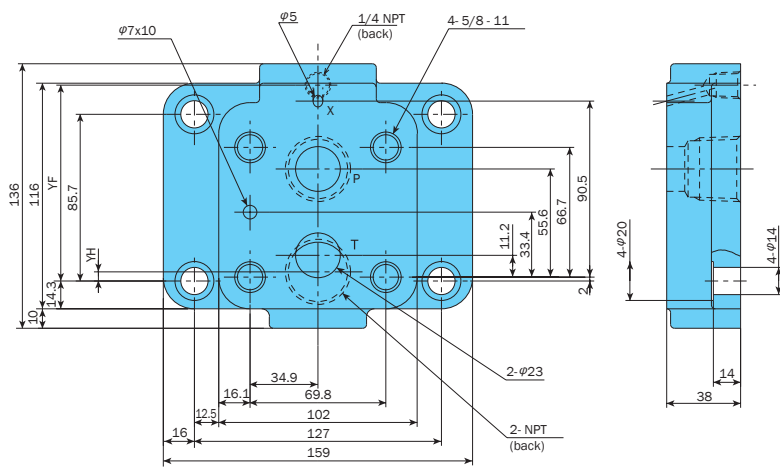

Attach a plug when the vent (X) port is not used.

Model No.	YF	YH
MRI-06-E10	92.5	13.2
MRI-06X-E10	100.7	4.7

Performance Curves

Hydraulic Operating Fluid Viscosity 32 centistokes

Pressure - Flow Rate Characteristics

RI-G03-C-20

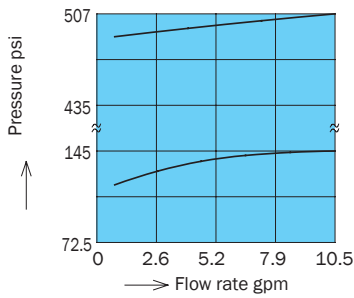

RI-G03-*-20

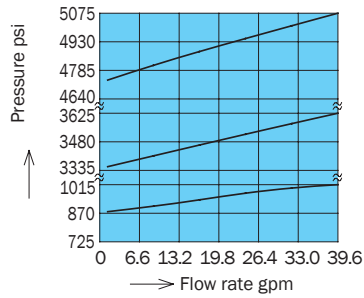

RI-G06-*-20

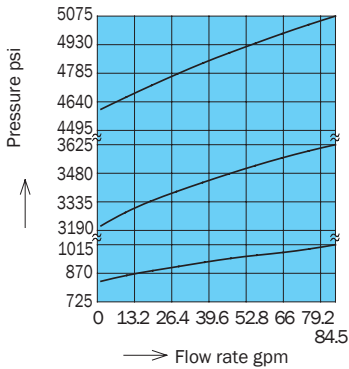

Note: The performance curves do not include T port back pressure.

Cross-sectional Drawing

RI-G**-*-20

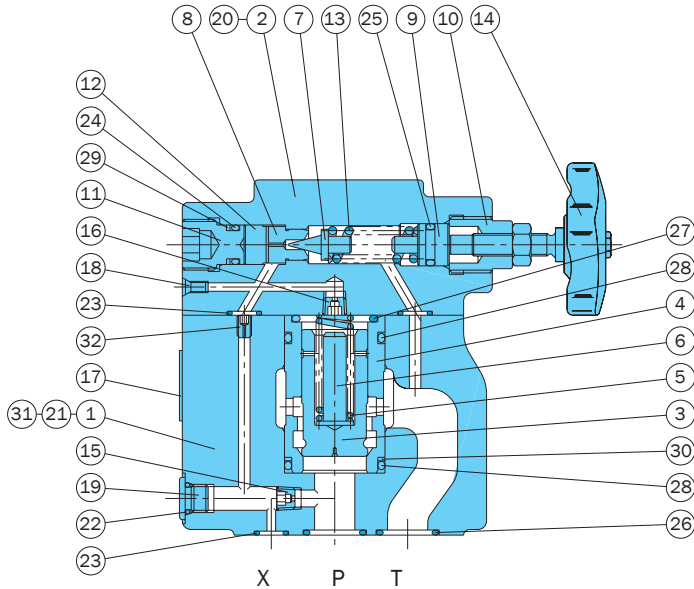

Part No.	Part Name	Part No.	Part Name
1	Body	17	Plate
2	Cover	18	Plug
3	Poppet	19	Plug
4	Sleeve	20	Screw
5	Spring	21	Pin
6	Spacer	22	O-ring
7	Poppet	23	O-ring
8	Seat	24	O-ring
9	Plunger	25	O-ring
10	Retainer	26	O-ring
11	Plug	27	O-ring
12	Collar	28	O-ring
13	Spring	29	Backup ring
14	Handle Assy	30	Backup ring
15	Orifice	31	Screw
16	Orifice	32	Choke

Seal Part List (Kit Model Number REBS-***)

Part No.	Part Name	Nominal Diameter/Part Number		Qty
		G03	G06	
22	O-ring	1B-P8	1B-P8	1
23	O-ring	1B-P9	1B-P9	3
24	O-ring	1B-P10A	1B-P10A	1
25	O-ring	1A-P11	1A-P11	1
26	O-ring	1B-P18	1B-P28	2
27	O-ring	1B-G25	1B-P28	1
28	O-ring	1B-G30	1B-P32	2
29	Backup ring	T2-P10A	T2-P10A	1
30	Backup ring	T2-G30	T2-P32	1

Note: O-ring 1A/B-** refers to JIS B 2401-1A/1B-**. For the *** part of the kit number, specify the valve size (G03, G06).

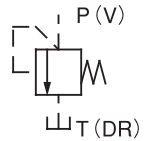

Remote Control Relief Valve

.52 to 3.9 gpm
3045 psi

Features

Connecting a relief valve or reducing valve to the vent port of a balanced piston type pressure control valve provides

simple remote control of pressure. RCD type can also be used as a direct type relief valve.

Specifications

Model No.		Nominal Diameter (Size)	Maximum Working Pressure psi	Maximum Flow Rate gpm	Pressure adjustment range psi	Weight lbs
Screw Mounting	Gasket mounting					
RCD-T02-1-11 3-11	-	1/4	3045 P, V ports	3.9	116 to 1015 507 to 3045	4.6
RC-T02-1-12 3-12	RC-G02-1-21 3-21					

Note: The pressure adjustment range indicates cracking pressure.

Understanding Model Numbers

RC - G 02 - 1 - (K) - 21

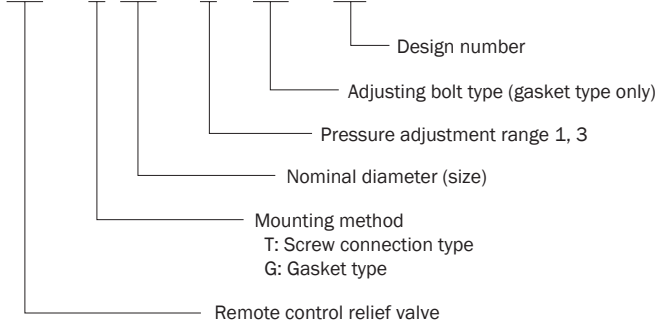

• Handling

- To adjust pressure, loosen the lock nut and then rotate the handle clockwise (rightward) to increase pressure or counterclockwise (leftward) to decrease it.
- Make sure that drain port back pressure is no greater than 29 psi.
- When configuring pipes for the pressure control valve and remote control valve, use of thick iron pipe with an inside diameter of no more than .15" and a connection length of no more than three meters is recommended. Pipe capacity can be a source of vibration.
- When an adjustment bolt type is required for the pressure adjustment block, insert K for the type specification. See the dimension drawings, RC-G02 only.
- Use the following to specify a sub plate.

Model No.	Weight lbs
MRC-02-20	2.2

- The following are the bundled mounting bolts.

Model No.	Bolt Dimensions	Q'ty	Tightening Torque ft lbs
RC-G02-*-21	M8 x 25r	4	14 to 18.5

Note: For mounting bolts, use 12T or equivalent.

Installation Dimension Drawings

RCD-T02-*-11 (Screw Mounting)

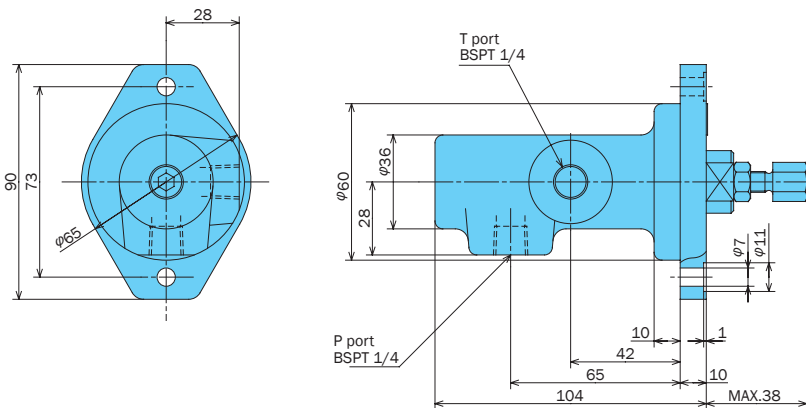

RC-T02-*-12 (Screw Mounting)

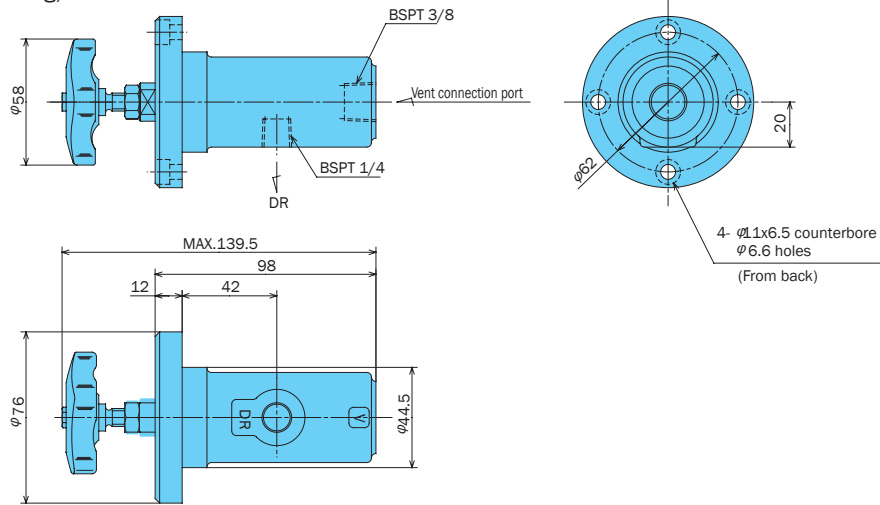

RC-G02-*-21 (Gasket Mounting)

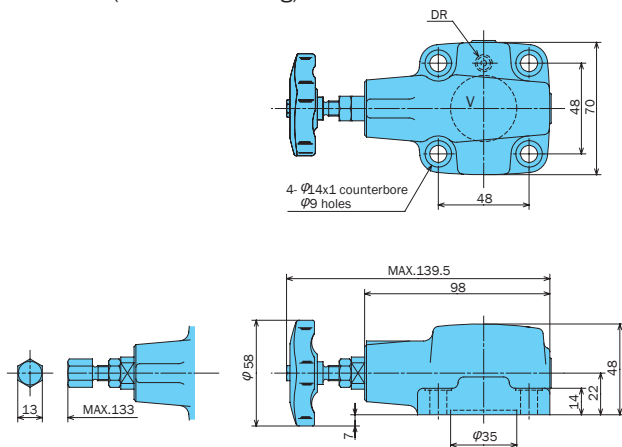

Sub Plate MRC-02-20

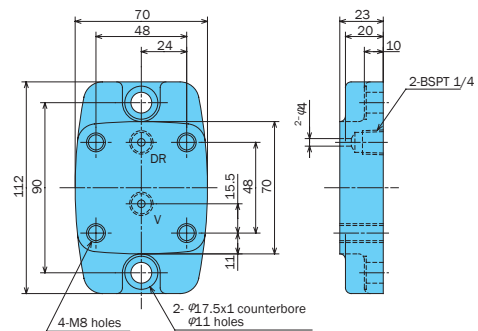

Cross-sectional Drawing

RCD-T02-*-11

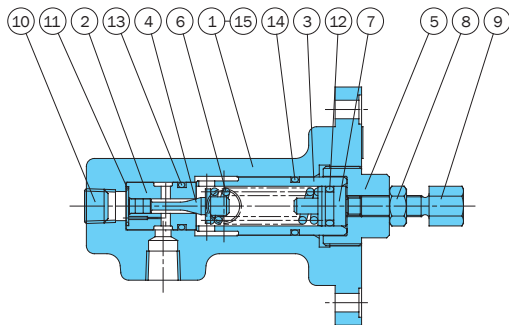

RC-G02-*- (K)-21

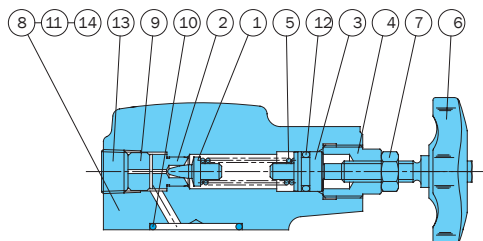

Part No.	Part Name	Part No.	Part Name
1	Body	12	O-ring
2	Sleeve	13	O-ring
3	Sleeve	14	O-ring
4	Poppet	15	Nameplate
5	Retainer		
6	Spring		
7	Guide		
8	Nut		
9	Screw		
10	Plug		
11	O-ring		

Seal Part List (Kit Model Number RCS-T02CD)

Part No.	Part Name	Part Number	Q'ty
11	O-ring	S12.5(NOK)	1
12	O-ring	1A-P11	1
13	O-ring	1B-P14	1
14	O-ring	1B-P18	1

Note: O-ring 1A/B-** refers to JIS B2401 1A/B.

Part No.	Part Name	Part No.	Part Name
1	Poppet	8	Cover
2	Seat	9	Collar
3	Plunger	10	O-ring
4	Retainer	11	O-ring
5	Spring	12	O-ring
6	Handle	13	Plug
7	Nut	14	Plate

Seal Part List (Kit Model Number RCBS-G02)

Part No.	Part Name	Part Number	Q'ty
10	O-ring	1B-G30	1
11	O-ring	1B-P6	1
12	O-ring	1A-P11	1

Note: O-ring 1A/B-** refers to JIS B2401 1A/B.



Solenoid Controlled Relief Valve 7.9 to 100 gpm 3045 psi

Features

This valve adds a wet type solenoid valve to a balanced type piston type relief valve to form a hydraulic device unload circuit. The shockless type has an internal structure that prevents shock generated during unloading. This valve can also be used in a pressure relief circuit, and has a maximum adjustment time of three seconds. See the pressure relief circuit example.

A two-pressure control circuit can be configured by adding a relief modular valve. Contact your agent for more information.

(Pressure Relief Circuit Example)

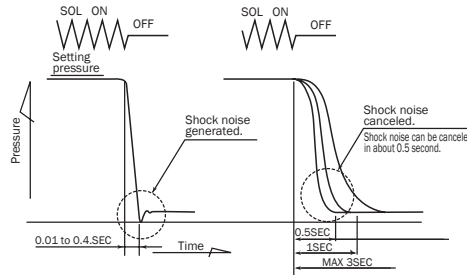

(Two-pressure Control Circuit Example)

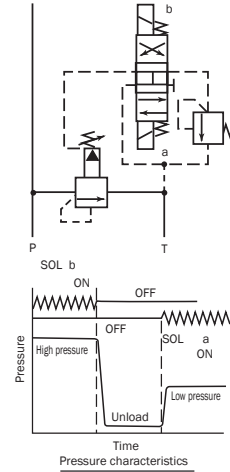

Specifications

Model No.		Nominal Diameter (Size)	Maximum Working Pressure psi	Maximum Flow Rate gpm	Pressure adjustment range psi	Weight lbs		JIS Symbol	Used Solenoid Valve Model Number
Screw Mounting	Gasket Mounting					T Type	G Type		
RSS (RSA) -T03-AQ 1/3-**-15	RSS (RSA) -G03-AQ 1/3-**-15	3/8	3045 P, X Ports	21	Type 1 0.8 to 7 116 to 1015	7	9.9		SS (SA) -G01-A3X-**-31
RSS (RSA) -T06-AQ 1/3-**-E23	RSS (RSA) -G06-AQ 1/3-**-E23	3/4		45		8.8	14		
RSS (RSA) -T10-AQ 1/3-**-E23	RSS (RSA) -G10-AQ 1/3-**-E23	1 1/4		100		19.4	22		
RSS (RSA) -T03-AR 1/3-**-15	RSS (RSA) -G03-AR 1/3-**-15	3/8		21	Type 3 3.5 to 21 507 to 3045	7	9.9		SS (SA) -G01-AR-**-31
RSS (RSA) -T06-AR 1/3-**-E23	RSS (RSA) -G06-AR 1/3-**-E23	3/4		45		8.8	14		
RSS (RSA) -T10-AR 1/3-**-E23	RSS (RSA) -G10-AR 1/3-**-E23	1 1/4		100		19.4	22		

Shockless Type

RSS (RSA) -T03-1/3-F-**-15	RSS (RSA) -G03-1/3-F-**-15	3/8	3045 P, X Ports	21	Type 1 1 to 7 145 to 1015 Type 3 3.5 to 21 507 to 3045	9.2	12		SS (SA) -G01-A8X0-**-31
RSS (RSA) -T06-1/3-F-**-E23	RSS (RSA) -G06-1/3-F-**-E23	3/4		45		11	16.3		
RSS (RSA) -T10-1/3-F-**-E23	RSS (RSA) -G10-1/3-F-**-E23	1 1/4		100		21.6	26.4		

Note: For information about electrical specifications, see the SS type and SA type solenoid valve items on pages D-4 and D-16.

• Handling

- To adjust pressure, loosen the lock nut and then rotate the adjusting bolt clockwise (rightward) to increase pressure or counterclockwise (leftward) to decrease it.
- To adjust the time from onload to unload, loosen the lock nut and rotate the restrictor adjusting bolt clockwise (rightward) to make the time longer, or counterclockwise (leftward) to make it shorter.
- Make sure that tank port back pressure is no greater than 29 psi.
- The ** before the design number in the model number of the solenoid valve used shows voltage. See the voltage symbols in the model number explanation.

- Pressure becomes unstable when at slow control flow rates. Use a flow rate of no less than 2.1 gpm for the 03, 06 sizes, and 2.6 gpm for the 10 size.
- Use 90 to 110% of rated voltage.
- The pressure adjustment range for the high vent type is 188 psi. Note that RSS (RSA) -T/G03 is not a high vent type.
- Use the following table for specification when a sub plate is required.

Model No.	Pipe Diameter	Weight lbs	Applicable Valve Type
MR-03-E10	3/8	3.5	RSS (RSA) -G03-**-**-15
MR-06-E20	3/4	7.7	RSS (RSA) -G06-**-**-23
MR-06X-E20			1
MR-10-E20	1 1/4	18.7	RSS (RSA) -G10-**-**-23
MR-10X-E20	1 1/2		

Note: See page relief valve page item on I-3 for dimensions.

- The following are the bundled mounting bolts.

Model No.	Bolt Dimensions	Q'ty	Tightening Torque ft lbs
RSS (RSA) -G03-**-**-15	3/8-16	4	33 to 40.5
RSS (RSA) -G06-**-**-23	5/8-11	4	140 to 173
RSS (RSA) -G10-**-**-23	7/8-9	4	272 to 339

Note: For mounting bolts, use 12T or equivalent.

- The coil surface temperature increases if this pump is kept continuously energized. Install the valve so there is not chance of it being touched directly by hand.

Understanding Model Numbers

RSS (RSA) - G 06 - A Q 1 - (H) - C1 * 23

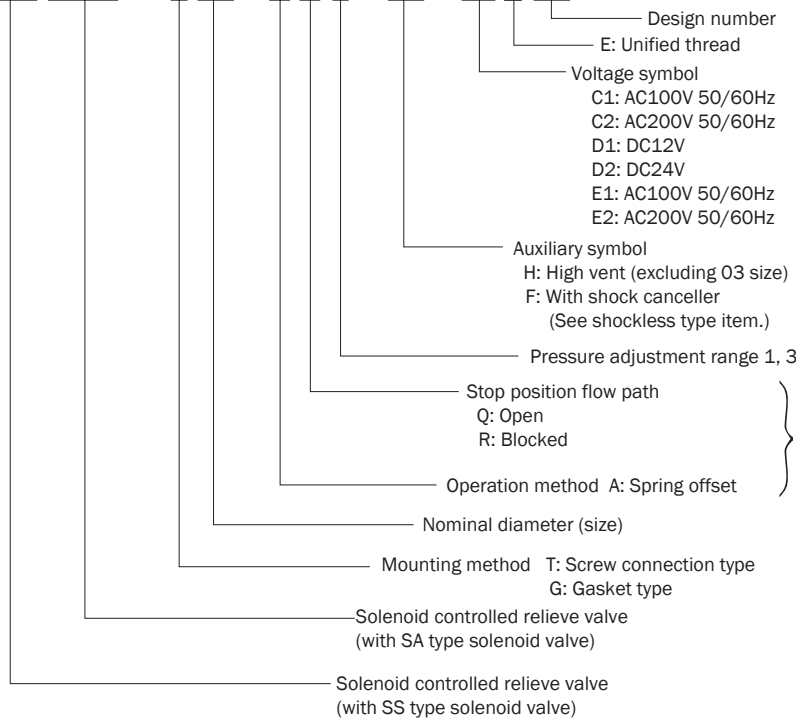

Other auxiliary symbols can be used
(enter them in alphabetic order if there are 2 or more).

With SS type solenoid valve	G, N, Q (R is omitted).
With SA type solenoid valve	GR, J, N, Q, R

Not required with the shockless type.

Installation Dimension Drawings

RSS -T**-A**-**-E23
(RSA)

Note: Dimensions marked with Ⓢ are for the RSA type.
Note: Dimensions in parentheses apply in the case of a DC solenoid valve.

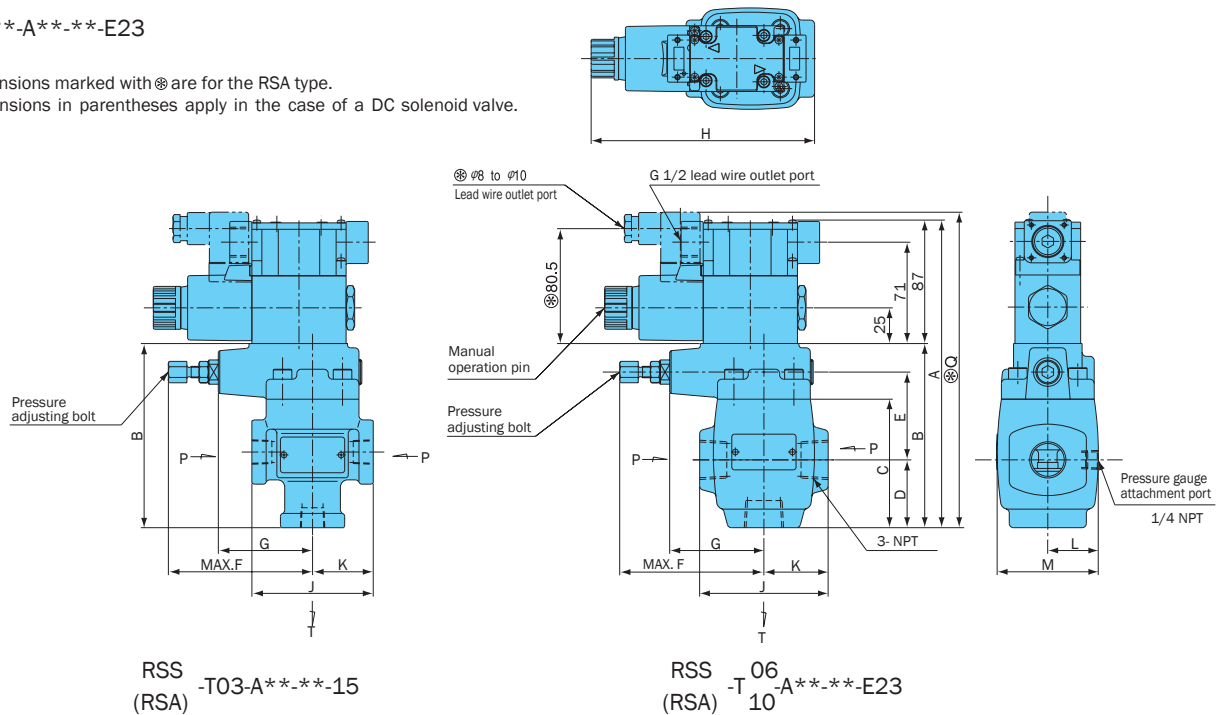

Model No.	A	B	C	D	E	F	G	H	J	K	L	M	N	Q
RSS (RSA) -T03-A**-**-15	214.5	129	90	53	56	101	66	154 (161)	85	42.5	32.5	65	3/8	221.5
RSS (RSA) -T06-A**-**-E23	214.5	129	90	47.5	61.5	101	66	156.5 (163.5)	90	45	35.5	71	3/4	221.5
RSS (RSA) -T10-A**-**-E23	239	153.5	111.5	62	72	98	63	164.5 (171.5)	125	62.5	47	94	1 1/4	246

RSS
(RSA) -G**-A**-**-E23

Note: Dimensions marked with Ⓢ & are for the RSA type.
Note: Dimensions in parentheses apply in the case of a DC solenoid valve.

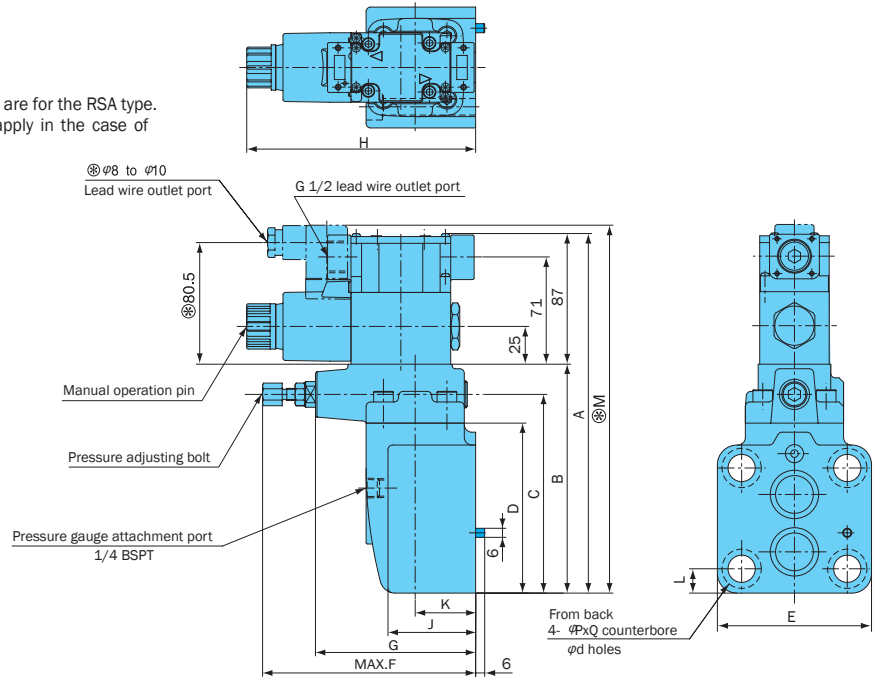

Model No.	A	B	C	D	E	F	G	H	J	K	L	P	Q	d	M
RSS (RSA) -G03-A**-**-15	214.5	129	109	90	80	141	106	150.5 (157.5)	72.5	40	13	17.5	10.8	11	221.5
RSS (RSA) -G06-A**-**-E23	237	151.5	131.5	112.5	102	141	106	151.5 (158.5)	58	40	16.1	26	1	18	244
RSS (RSA) -G10-A**-**-E23	248	162.5	143	120.5	127	148	113	152 (159)	80	50	17.7	32	1	22	255

Note: For gasket surface dimensions, see R-G**-** 12/20.

RSS
(RSA) -T**-*-F**-*-E23

Note: Dimensions marked with Ⓢ & are for the RSA type.
Note: Dimensions in parentheses apply in the case of a DC solenoid valve.

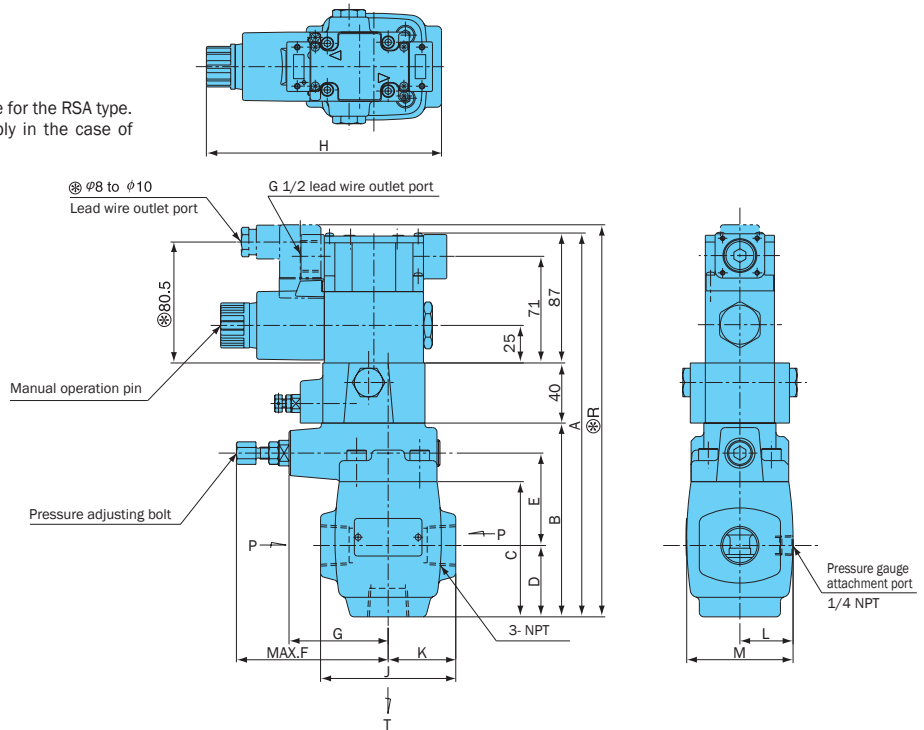

Model No.	A	B	C	D	E	F	G	H	J	K	L	M	N	Q	R
RSS (RSA) -T03-*-F**-*-15	254.5	129	90	53	56	101	66	154 (161)	85	42.5	32.5	65	32	3/8	261.5
RSS (RSA) -T06-*-F**-*-E23	254.5	129	90	47.5	61.5	101	66	156.5 (163.5)	90	45	35.5	71	33	3/4	261.5
RSS (RSA) -T10-*-F**-*-E23	279	153.5	111.5	62	72	98	63	164.5 (171.5)	125	62.5	47	94	32.5	1 1/4	286

RSS
(RSA) -G***-F***-23

Note: Dimensions marked with ⌀ & are for the RSA type.
Note: Dimensions in parentheses apply in the case of a DC solenoid valve.

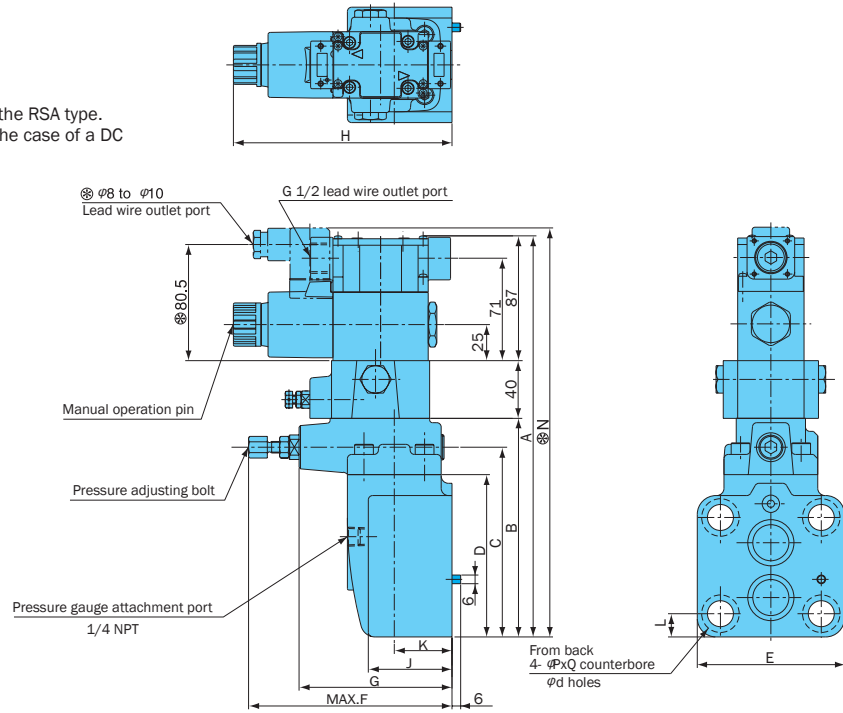

Model No.	A	B	C	D	E	F	G	H	J	K	L	M	N	P	Q	d
RSS (RSA) -G03*-F***-15	254.5	129	109	90	80	141	106	150.5 (157.5)	72.5	40	13	32	261.5	17.5	10.8	11
RSS (RSA) -G06*-F***-23	277	151.5	131.5	112.5	102	141	106	151.5 (158.5)	58	40	16.1	33	284	26	1	18
RSS (RSA) -G10*-F***-23	288	162.5	143	120.5	127	148	113	152 (159)	80	50	17.7	32.5	295	32	1	22

Note: For gasket surface dimensions, see R-G*** 12/20.

Cross-sectional Drawing

RSS-G***-F***-23

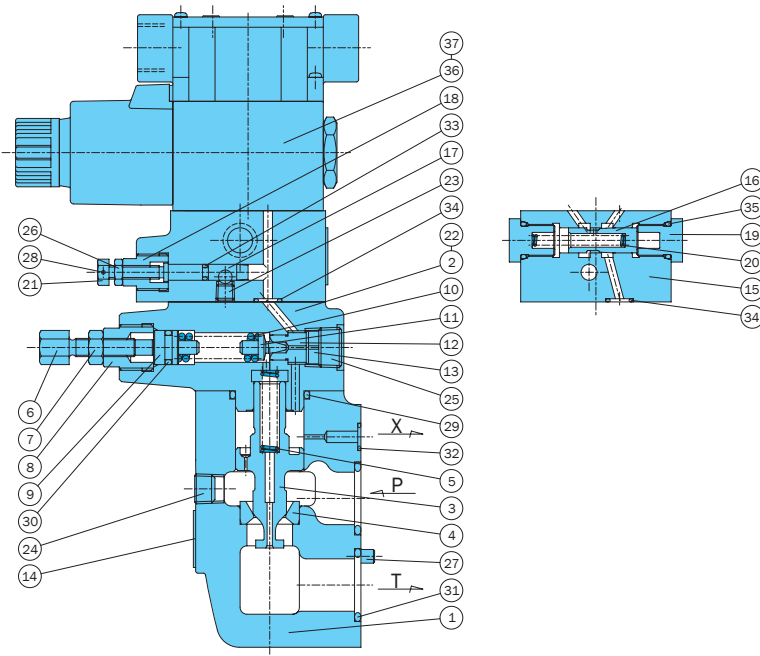

Part No.	Part Name	Part No.	Part Name
1	Body	20	Spring
2	Cover	21	Nut
3	Spool	22	Screw
4	Seat	23	Plug
5	Spring	24	Plug
6	Screw	25	Plug
7	Nut	26	Nut
8	Retainer	27	Spring pin
9	Plunger	28	Spring pin
10	Spring	29	O-ring
11	Poppet	30	O-ring
12	Seat	31	O-ring
13	Collar	32	O-ring
14	Nameplate	33	O-ring
15	Body	34	O-ring
16	Spool	35	O-ring
17	Throttle	36	Solenoid Valves
18	Retainer	37	Screw
19	Spring guide		

Seal Parts List (Kit Model Number RSBS-***F)

Part No.	Part Name	Type/Part Number			Q'ty
		RSS-G03-*-F-**-15	RSS-G06-*-F-**-23	RSS-G10-*-F-**-23	
29	O-ring	1B-G30	1B-G30	1B-G40	1
30	O-ring	1A-P11	1A-P11	1A-P11	1
31	O-ring	1B-P20	1B-P26	1B-G35	2
32	O-ring	1B-P7	1B-P9	1B-P9	1
33	O-ring	1B-P4	1B-P4	1B-P4	1
34	O-ring	1B-P9	1B-P9	1B-P9	2
35	O-ring	1B-P12.5	1B-P12.5	1B-P12.5	2

- Note: 1. O-ring 1A/B-** refers to JIS B2401-1A/B.
 2. For the *** part of the kit number, specify the valve size (G03, G06, G10).
 3. SS (SA)-G01 pilot valve seal is available separately. For details, see pages D-14 (D-26).



RI Series Solenoid Controlled Relief Valve

39.6 to 84.5 gpm
5075 psi

Features

This valve adds a wet type solenoid valve to a balanced type piston type relief valve to form a hydraulic device unload circuit. The shockless type has an internal structure that prevents shock generated during unloading. This valve can also be used in a pressure relief circuit, and has a maximum adjustment time of three seconds. See the pressure relief circuit example.

A two-pressure control circuit can be configured by adding a relief modular valve. Contact your agent for more information.

(Two-pressure Control Circuit Example)

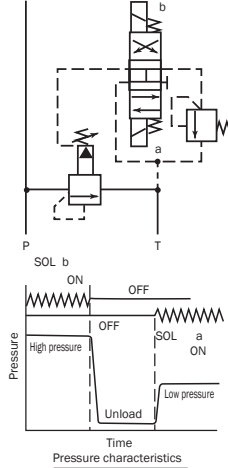

(Pressure Relief Circuit Example)

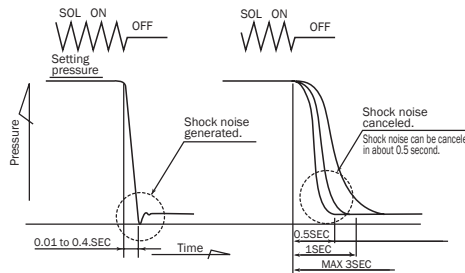

Specifications

Model No.	Nominal Diameter (Size)	Maximum Flow Rate gpm	Maximum Working Pressure psi	Pressure adjustment range psi	Weight lbs	Gasket Surface Dimensions	JIS Symbol	Used Solenoid Valve Type
RIS-G03-AQ 1 3-**-21 5	3/8	39.6	5075 P, X Ports	Type 1: 116 to 1015	13.2	ISO 6264-AR-06-2-A		SS-G01-A3X-**-31
RIS-G06-AQ 1 3-**-21 5	3/4	84.5		Type 3: 507 to 3625	15.6	ISO 6264-AS-08-2-A		
RIS-G03-AR 1 3-**-21 5	3/8	39.6		Type 5: 507 to 5075	13.2	ISO 6264-AR-06-2-A		SS-G01-AR-**-31
RIS-G06-AR 1 3-**-21 5	3/4	84.5			15.6	ISO 6264-AS-08-2-A		

Shockless Type

RIS-G03-3-F-**-21 1 5	3/8	39.6	5075 P, X Ports	Type 1: 145 to 1015	15.4	ISO 6264-AR-06-2-A		SS-G01-A3X-**-31
RIS-G06-3-F-**-21 1 5	3/4	84.5		Type 3: 507 to 3625	17.8	ISO 6264-AS-08-2-A		

Note: For electrical specifications, see the SS type solenoid valve item on page D-4.

Handling

- To adjust pressure, loosen the lock nut and then rotate the handle clockwise (rightward) to increase pressure or counterclockwise (leftward) to decrease it.
- To adjust the time from onload to unload, loosen the lock nut and rotate the restrictor adjusting bolt clockwise (rightward) to make the time longer, or counterclockwise (leftward) to make it shorter.
- Make sure that tank port back pressure is no greater than 29 psi.
- The ** before the design number in the model number of the solenoid valve used shows voltage. See the voltage symbols in

- the model number explanation.
- A small control flow rate can cause pressure instability. Use a control flow rate that is at least 2.1 gpm. Use a drain type relief valve in the case of a flow rate that is less than the minimum flow rate.
- Use 90 to 110% of rated voltage. Use the following table for specification when a sub plate is required. Maximum operating pressure is 3625 psi.

Model No.	Pipe Diameter	Weight lbs	Applicable Valve Model
MRI-03-E10	3/8	5.7	RIS-G03
MRI-03X-E10	1/2		
MRI-06-E10	3/4	7.7	RIS-G06
MRI-06X-E10	1		

- The following are the bundled mounting bolts.

Model No.	Bolt Dimensions	Qty	Tightening Torque ft lbs
RIS-G03-**-**-21	3/8 - 16	4	55 to 70
RIS-G06-**-**-21	5/8 - 11	4	140 to 173

Note: For mounting bolts, use Grade 8 or equivalent.

- The coil surface temperature increases if this pump is kept continuously energized. Install the valve so there is not chance of it being touched directly by hand.

Understanding Model Numbers

RIS - G 06 - A Q 1 - (F) - C1 - 21

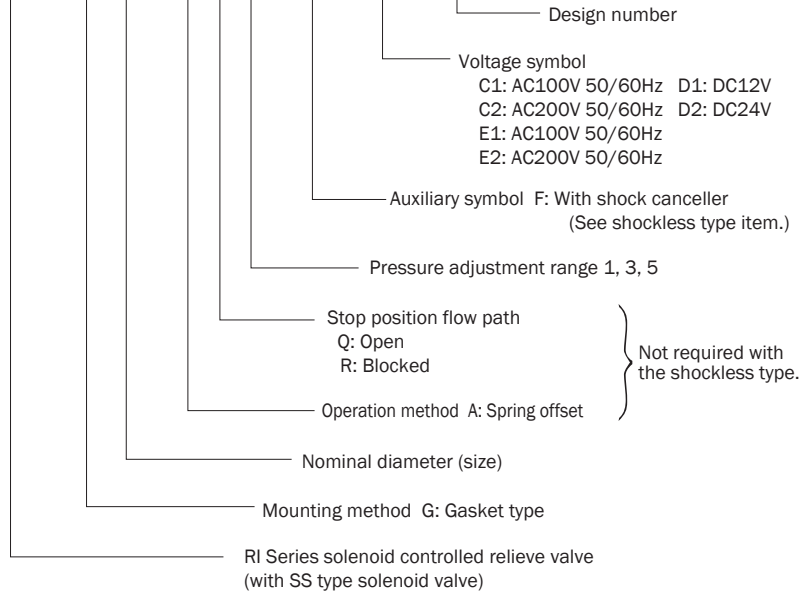

Other auxiliary symbols G, N, and Q (R is omitted) can be used (enter them in alpha-betic order if there are 2 or more).

Installation Dimension Drawings

RIS-G**-A**-**-21

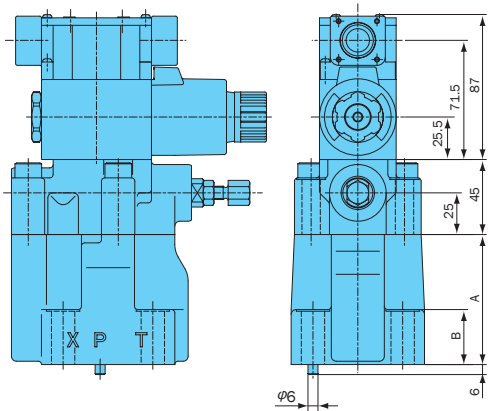
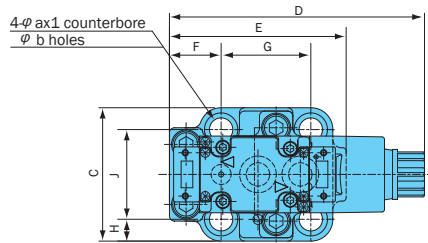

RIS-G**-*-F**-**-21

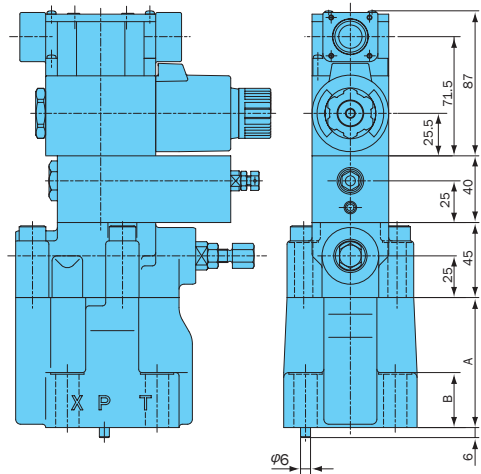

Model No.	A	B	C	D	E	F	G	H	J	a	b
RIS-G03-**-**-21	78	32	80	153 (160)	106	31	53.8	13.1	53.8	20	14
RIS-G06-**-**-21	83	36	100	162 (169)	119	37	66.7	15	70	26	17.5

Note: 1. For gasket surface dimensions, see RI-G**-** on page I-5.
 2. Figures in (parenthesis) are for the DC solenoid valve.

Cross-sectional Drawing

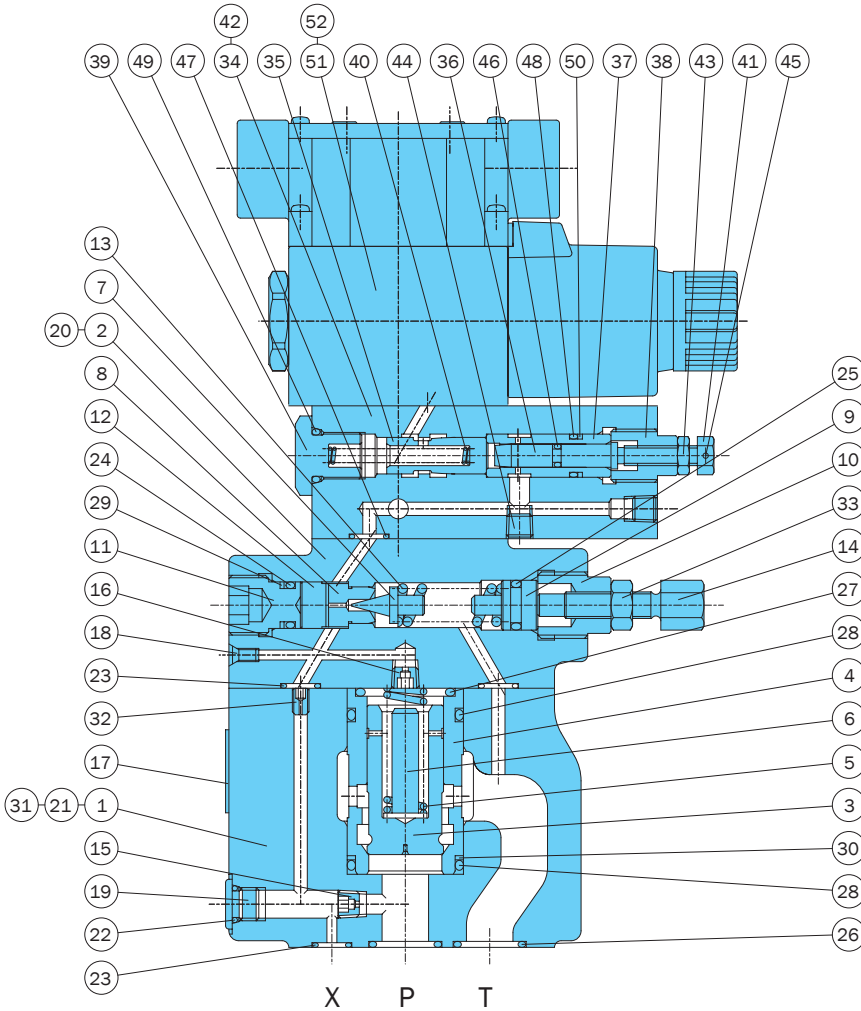

Part No.	Part Name
1	Body
2	Cover
3	Poppet
4	Sleeve
5	Spring
6	Spacer
7	Poppet
8	Seat
9	Plunger
10	Retainer
11	Plug
12	Collar
13	Spring
14	Handle assy
15	Orifice
16	Orifice
17	Plate

Part No.	Part Name
18	Plug
19	Plug
20	Screw
21	Pin
22	O-ring
23	O-ring
24	O-ring
25	O-ring
26	O-ring
27	O-ring
28	O-ring
29	Backup ring
30	Backup ring
31	Screw
32	Choke
33	Nut
34	Body

Part No.	Part Name
35	Spool
36	Throttle
37	Sleeve
38	Retainer
39	Guide
40	Spring
41	Nut
42	Plate
43	Nut
44	Plug
45	Pin
46	O-ring
47	O-ring
48	O-ring
49	O-ring
50	Backup ring
51	Solenoid Valves
52	Screw

Seal Part List (Kit Model Numbers: Main REBS-***, Restrictor Valve DFS-01H)

Component Parts	Part No.	Part Name	Nominal Diameter/Part Number		Qty
			G03	G06	
Main	22	O-ring	1B-P8	1B-P8	1
	23	O-ring	1B-P9	1B-P9	3
	24	O-ring	1B-P10A	1B-P10A	1
	25	O-ring	1A-P11	1A-P11	1
	26	O-ring	1B-P18	1B-P28	2
	27	O-ring	1B-G25	1B-P28	1
	28	O-ring	1B-G30	1B-P32	2
	29	Backup ring	T2-P10A	T2-P10A	1
	30	Backup ring	T2-G30	T2-P32	1
	Restrictor Valve	46	O-ring	1B-P4	
47		O-ring	1B-P9		2
48		O-ring	1B-P10		1
49		O-ring	1B-P12.5		1
50		Backup ring	T2-P10		1

- Note: 1. O-ring 1A/1B-** refers to JIS B 2401-1A/1B-**.
 2. For the *** part of the kit number, specify the valve size (G03, G06).
 3. The restrictor valve kit is required only when a shockless valve is included.
 4. SS (SA)-G01 pilot valve seal is available separately. For details, see pages D-14 (D-26).

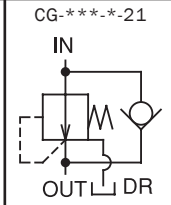
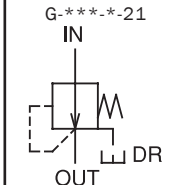

Pressure Reducing (and Check) Valve

5.2 to 73.9 gpm
3045 psi

Features

This valve is used when part of the circuit uses pressure that is lower than the main circuit.

Even when pressure changes in the primary main circuit, the reduced secondary pressure is adjusted automati-

cally and maintained at a constant level. Connecting a remote control valve to the vent port allows remote control of adjustment pressure.

The mounting surface of the gasket conforms to the ISO standards shown in the table below.

Specifications

Model No.		Nominal Diameter (Size)	Maximum Working Pressure psi	Maximum Flow Rate gpm	Pressure adjustment range psi	Weight lbs		Gasket Surface Dimensions
Screw Mounting	Gasket Mounting					T Type	G Type	
(C)G-T03- A-21 B-21	(C)G-G03- A-21 B-21	3/8	3045 IN, OUT, Vent Port	5.2	36 to 145 43 to 362	7.2 7.9	8.5 9.2	ISO 5781-AG-06-2-A
(C)G-T03-1-21 3-21	(C)G-G03-1-21 3-21	3/8			116 to 1015 507 to 3045	7.2 7.9	8.5 9.2	
(C)G-T06-1-21 3-21	(C)G-G06-1-21 3-21	3/4		116 to 1015 507 to 3045	12.5 13.4	13.6 14.5	ISO 5781-AH-08-2-A	
(C)G-T10-1-21 3-21	(C)G-G10-1-21 3-21	1 1/4		116 to 1015 507 to 3045	22 25	26 29	ISO 5781-AJ-10-2-A	

Weight values in parentheses are for when a check valve is included. The cracking pressure of the check valve is 14.5 psi.

Understanding Model Numbers

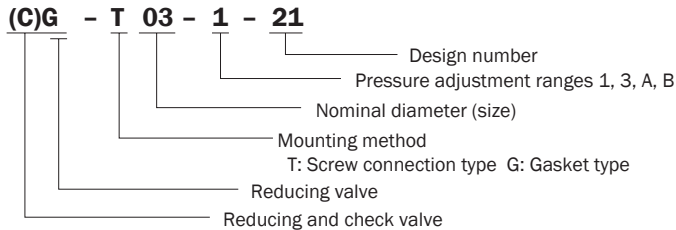

Installation Dimension Drawings

G-T***-21 (Screw Mounting)

Model No.	Dimensions (mm)					
	A	B	C	D	E	F
G-T03-*21	146	118.5	52	23	52.5	19
G-T06-*21	174	148	66.5	27	64	24
G-T10-*21	203.5	178.5	80.5	28	73	30

Model No.	Dimensions (mm)						
	G	H	J	K	L	M	P
G-T03-*21	35	70	40	32	63	36	3/8
G-T06-*21	47.5	95	50	37	73	54	3/4
G-T10-*21	54	108	68.5	47.5	95	69	1 1/4

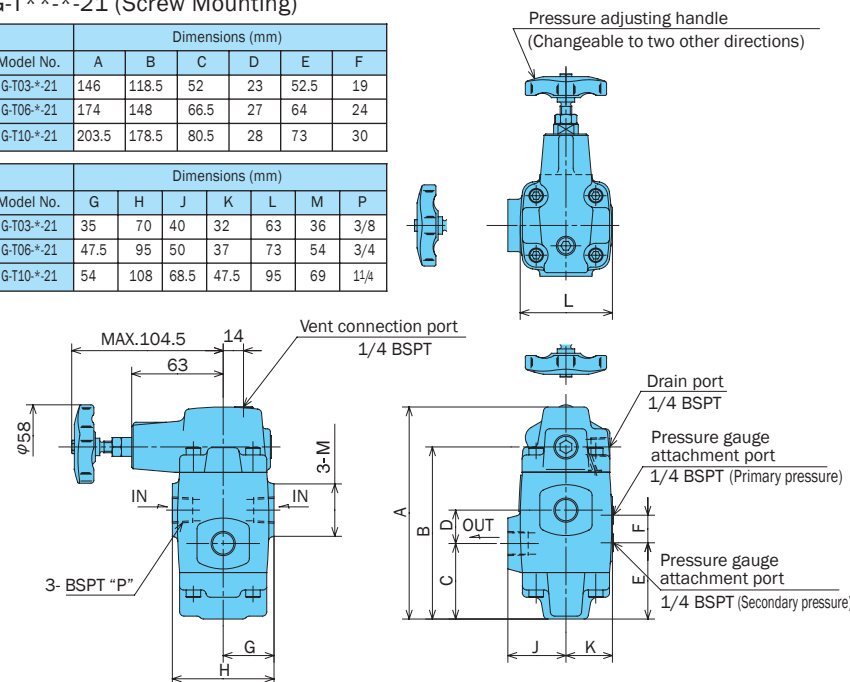

- Handling
- 1 Provide an independent drain pipe directly to the tank.
 - 2 When using a remote control valve, connect piping to the reducing valve vent port. Pipe capacity can be a source of vibration. Use of thick iron pipe with an inside diameter of no more than .15" and a connection length of no more than three meters is recommended.
 - 3 Use the following table for specification when a sub plate is required.

Model No.	Pipe Diameter	Weight lbs	Applicable Valve Model
MG-03-20	3/8	3.5	(C)G-G03-*-21
MG-03X-20	1/2		
MG-06-20	3/4	8.6	(C)G-G06-*-21
MG-06X-20	1		
MG-10-20	1 1/4	14.7	(C)G-G10-*-21
MG-10X-20	1 1/2		

These sub plates can also be used for pressure control valves.

- 4 The following are the bundled mounting bolts.

Model No.	Bolt Dimensions	Q'ty	Tightening Torque ft lbs
(C)G-G03-*-21	M10 × 75 ℓ	4	33 to 40.5
(C)G-G06-*-21	M10 × 85 ℓ	4	
(C)G-G10-*-21	M10 × 105 ℓ	6	

Note: For mounting bolts, use 12T or equivalent.

G-G*-*-21 (Gasket Mounting)

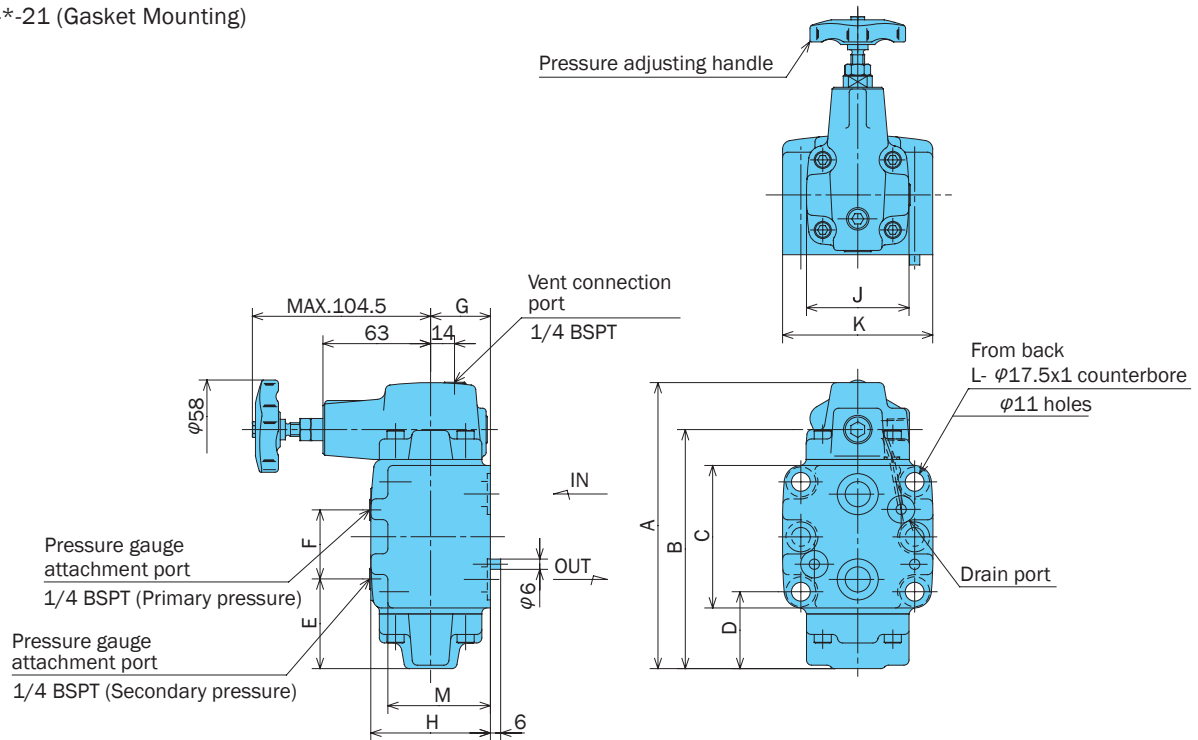

Model No.	A	B	C	D	E	F	G	H	J	K	L	M
G-G03*-21	146	118.5	62	45.1	52.5	19	35	70	60	88	4	60
G-G06*-21	174	148	82	51.4	64	24	40	80	70	102	4	70
G-G10*-21	203.5	178.5	102	54	73	30	51	102	92	122	6	92

Note: The orientation of the pressure adjusting handle cannot be change.

CG-T*-*-21 (Screw Mounting)

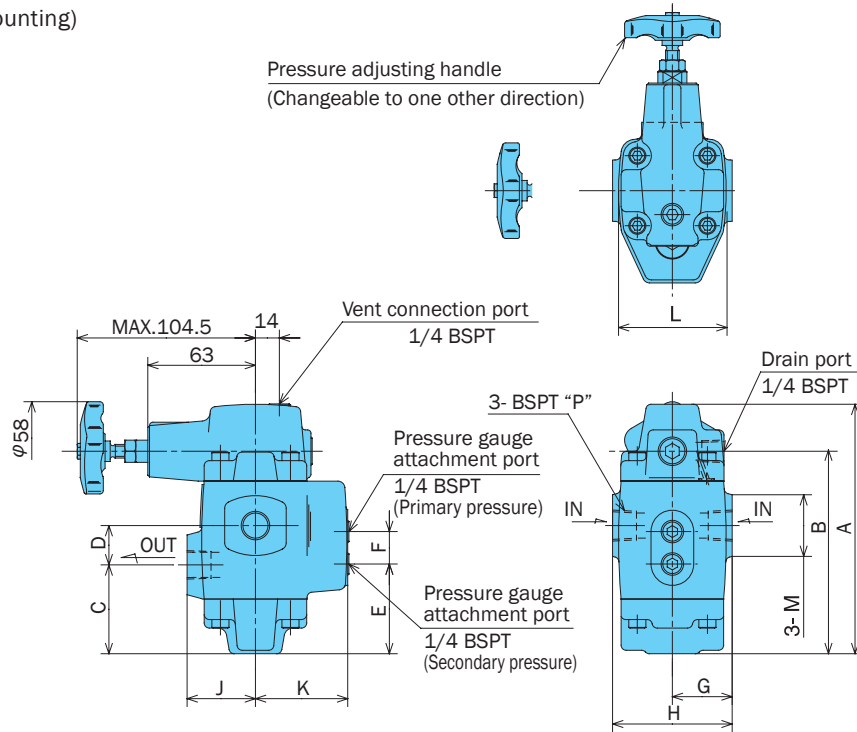

Model No.	A	B	C	D	E	F	G	H	J	K	L	M	P
CG-T03*-21	146	118.5	52	23	52.5	19	35	70	40	54	63	36	3/8
CG-T06*-21	174	148	66.5	27	64	24	47.5	95	50	60	73	54	3/4
CG-T10*-21	203.5	178.5	80.5	28	73	30	54	108	68.5	80	95	69	1 1/4

Note: After the orientation of the pressure adjusting handle has been changed, also modify the cover alignment surface ring (1B-P6).

CG-G**-*-21 (Gasket Mounting)

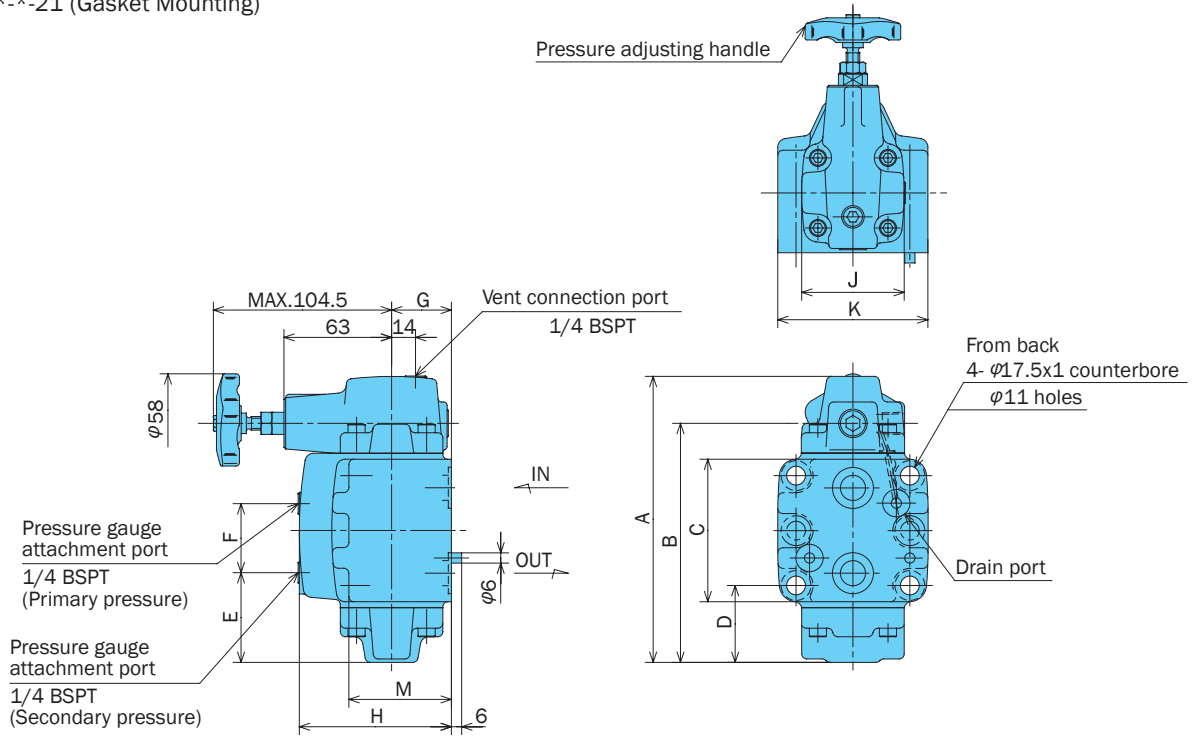

Model No.	Dimensions mm											
	A	B	C	D	E	F	G	H	J	K	L	M
CG-G03-*-21	146	118.5	62	45.1	52.5	19	35	89	60	88	4	60
CG-G06-*-21	174	148	82	51.4	64	24	40	100	70	102	4	70
CG-G10-*-21	203.5	178.5	102	54	73	30	51	131	92	122	6	92

Note: The orientation of the pressure adjusting handle cannot be change.

Sub Plate MG-***-20

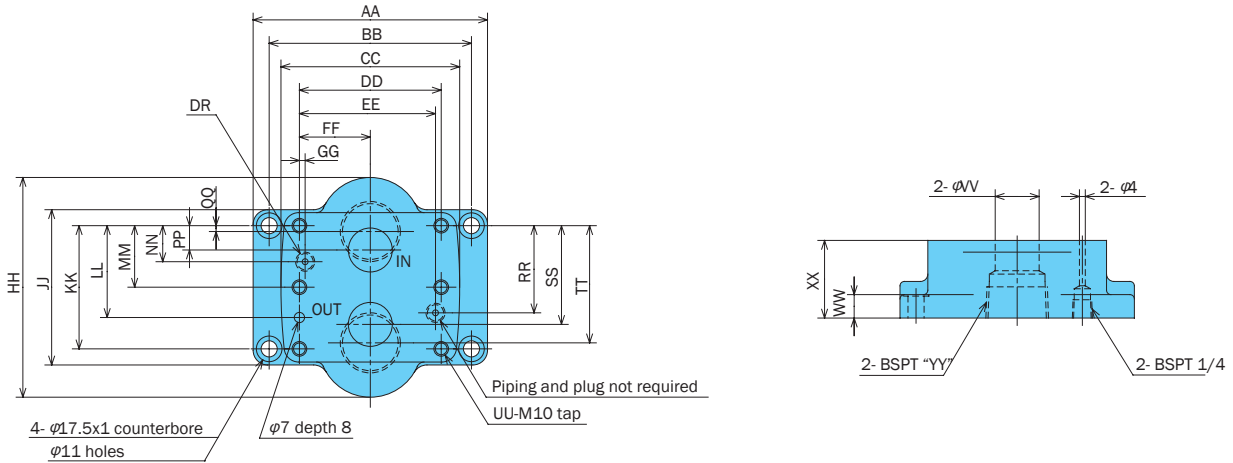

Model No.	Dimensions mm																						
	AA	BB	CC	DD	EE	FF	GG	HH	JJ	KK	LL	MM	NN	PP	QQ	RR	SS	TT	UU	VV	WW	XX	YY
MG-03-20	128	106.4	88	66.6	58.7	33.3	7.9	76	62	42.9	31.8	-	21.4	7.2	3.5	21.5	35.7	39.5	4	14	11	30	3/8
MG-03X-20																							1/2
MG-06-20	146	123.8	102	79.3	72.9	39.7	6.4	110	82	60.3	44.5	-	20.6	11.1	3.7	39.7	49.2	56.7	4	22	16	40	3/4
MG-06X-20																							1
MG-10-20	160	138.1	122	96.8	92.9	48.4	3.9	150	102	84.1	62.7	42.1	24.6	16.7	4.1	59.5	67.5	80.1	6	30	16	53	1 1/4
MG-10X-20																							1 1/2

Performance Curves

Hydraulic Operating Fluid Viscosity 32 centistokes

Pressure Loss Characteristics

(C)G-G03-*-21

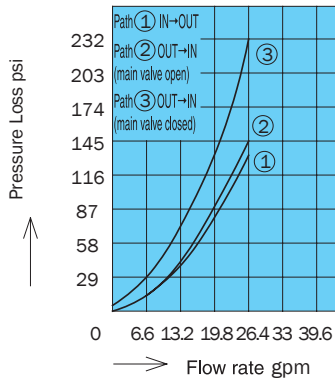

(C)G-T03-*-21

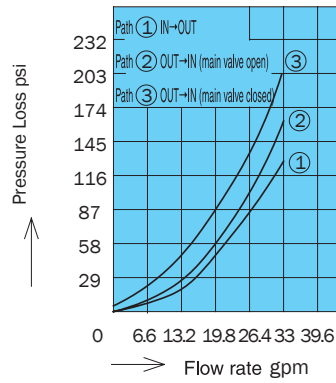

Pressure - Drain Flow Rate Characteristics

(C)G-***-*-21

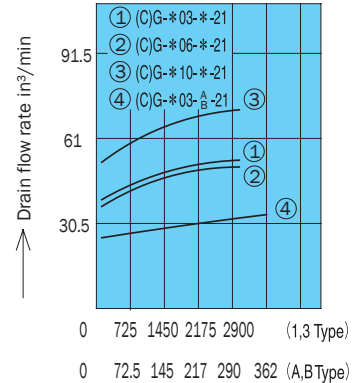

→ Differential pressure psi
Secondary Pressure - Flow Rate Characteristics

(C)G-G06-*-21

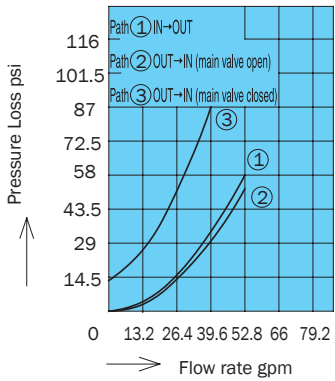

(C)G-T06-*-21

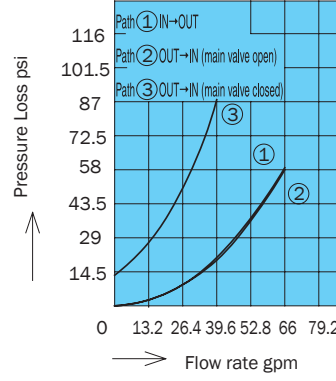

(C)G-*03-^A/_B-21

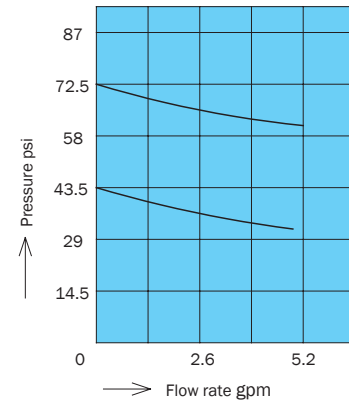

(C)G-G10-*-21

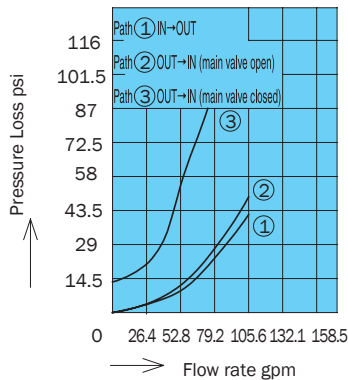

(C)G-T10-*-21

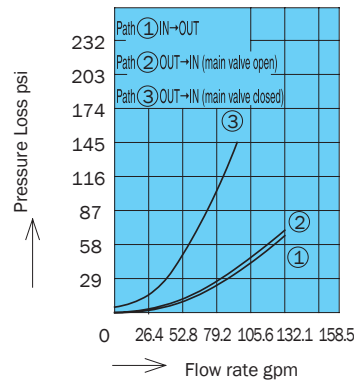

Cross-sectional Drawing

(C)G-G**-^A/_B-21

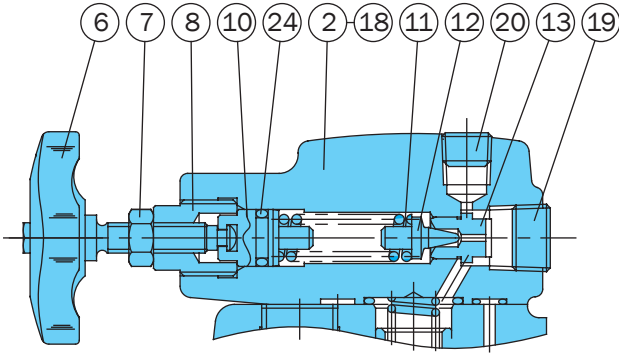

CG-G**-**-21

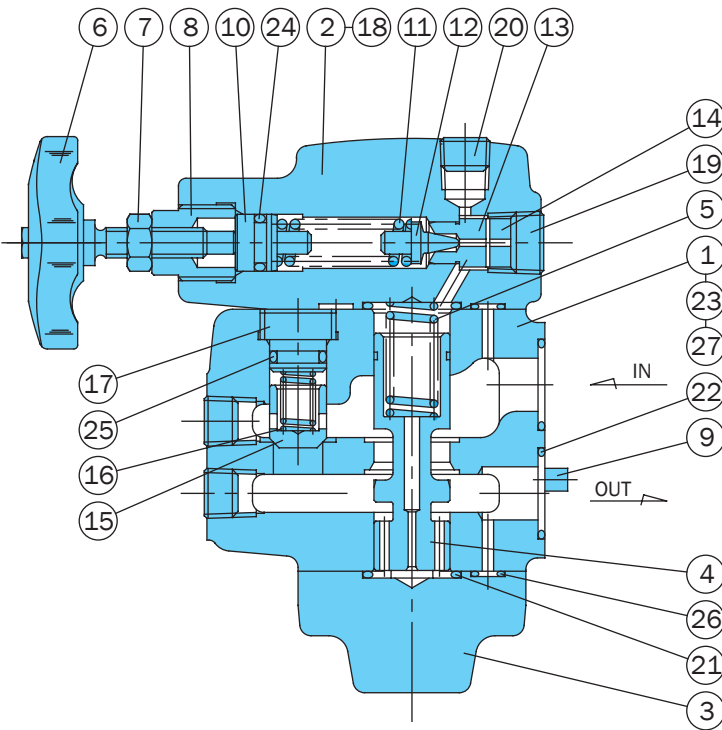

Part No.	Part Name
1	Body
2	Cover
3	Cover
4	Piston
5	Spring
6	Handle
7	Nut
8	Retainer
9	Spring pin
10	Push rod
11	Spring
12	Poppet
13	Seat
14	Collar
15	Poppet
16	Spring
17	Spring guide
18	Screw
19	Plug
20	Plug
21	O-ring
22	O-ring
23	O-ring
24	O-ring
25	O-ring
26	O-ring
27	Nameplate

Note: Part numbers 15, 16, 17, and 25 are not required when there is no check valve.

Seal Part List (Kit Model Number RGSB-***)

Part No.	Part Name	Part Number						Q'ty
		CG-G03*-21	CG-T03*-21	CG-G06*-21	CG-T06*-21	CG-G10*-21	CG-T10*-21	
21	O-ring	1B-P22	1B-P22	1B-G30	1B-G30	1B-G40	1B-G40	2
22	O-ring	1B-P20	-	1B-P26	-	1B-G35	-	2
23	O-ring	1B-P12	-	1B-P12	-	1B-P12	-	2
24	O-ring	1A-P11	1A-P11	1A-P11	1A-P11	1A-P11	1A-P11	1
25	O-ring	1B-P11	1B-P11	1B-P14	1B-P14	1B-P22	1B-P22	1
26	O-ring	1B-P6	1B-P6	1B-P6	1B-P6	1B-P6	1B-P6	4

Note: O-ring 1A/B-** refers to JIS B2401 1A/B-**.

*** in the kit number is used for specification of the valve size (G03, T06, etc.) To specify inclusion of a check valve, add C to the end.

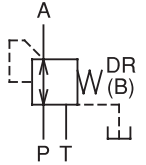

Balancing Valve (Pressure Reducing and Relief Valve)

7.9 to 13.2 gpm
2030 psi

Features

2-in-1 operation allows a simpler circuit configuration. Combination valve that provides both pressure reducing and counter balance functions.

Pressure adjustment using a single screw (bolt). Compact and lightweight valve that can be mounted using the same methods as a O1, O3 size solenoid valve.

Specifications

Model No.	Nominal Diameter (Size)	Maximum Working Pressure psi	Maximum Flow Rate gpm	Pressure adjustment range psi	Weight lbs	Gasket Surface Dimensions
GR-G01- A1-20 A2	1/8	3045 P port	30	116 to 1015 507 to 2030	3.3	ISO 4401-03-02-0-94
GR-G03- A1-(B)-20 A2	3/8		50	145 to 1015 507 to 2030	7.7	ISO 4401-05-04-0-94

Understanding Model Numbers

GR - G 03 - A 1 - BK - 20

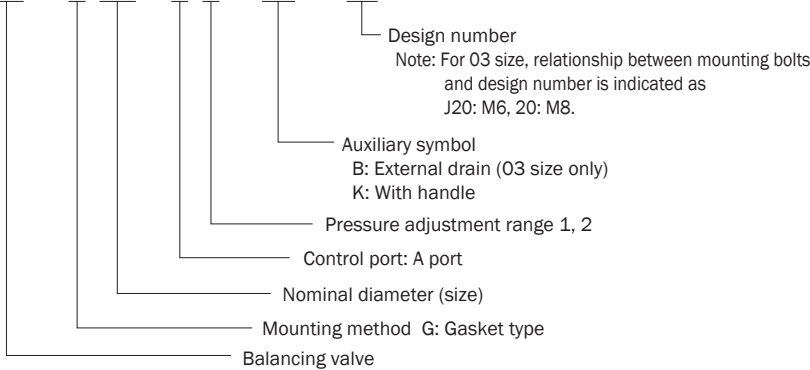

Installation Dimension Drawings

GR-G01-A*-20

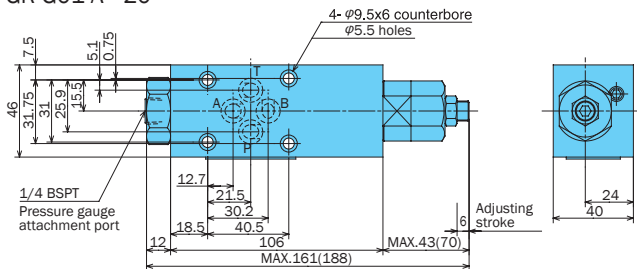

GR-G03-A*-B-20

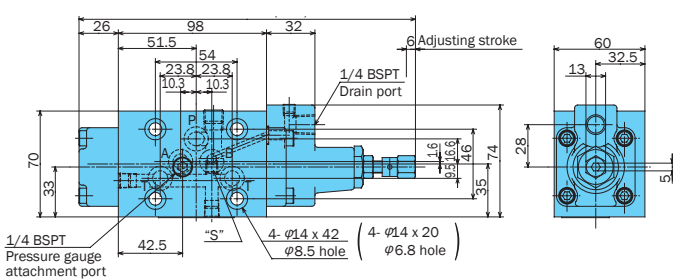

Note: 1. For size O3, an escape valve with piping from the drain discharge port is standard for the drain (GR-G03-A*-B-20). To change from internal drain to external drain, install a plug (NPTF 1/16) in part S, and remove the drain discharge port plug (1/4 BSPT). To change from external drain to internal drain, install a plug (1/4 BSPT) into the drain discharge port, and remove the S part plug (NPTF 1/16). In this case, however, the B port cannot be used as the tank port.
2. Dimensions in parentheses show dimensions with handle (K type).

- Handling
- To adjust pressure, loosen the lock nut and then rotate the adjusting screw (bolt) clockwise (rightward) to increase pressure or counterclockwise (leftward) to decrease it.
 - For the O1 size, draining is from the gasket side B port.
 - For the drain of a O3 size valve when auxiliary symbol B is specified, run a pipe from the drain discharge port directly to the tank. The drain discharge port can also be plugged for direct draining from the gasket side B port. In the case of modification, be sure to change the valve type marking on the nameplate. When using drain piping, use a tightening torque of 16-18.4 ft lbs for pipe joints.
 - The drain of O3 size valve that does not have a B auxiliary symbol can be directly from the T port.
 - Make sure that drain back pressure is no greater than 29 psi.
 - When an adjustment handle is required for pressure adjustment block, insert K for the type specification.
 - Set the difference between the pressure at the primary circuit (port P) and the secondary circuit (port A) at least 72 psi.
 - Use the following table for specification when a sub plate is required.

Model No.	Pipe Outlet Size	Weight lbs
MSA-01Y-E10	3/8	2.6
MSA-03-E10	3/8	8.3
MSA-03X-E10	1/2	

The following are the bundled mounting bolts.

Model No.	Bolt Dimensions	Q'ty	Tightening Torque ft lbs
GR-G01-A*-20	10-24 x 13/4"	4	3.6 to 5
GR-G03-A*-20	1/4-20 x 11/8"	4	14.7 to 18.4

Note: For mounting bolts, use grade 8 or equivalent.

Adjusting Handle (Option)

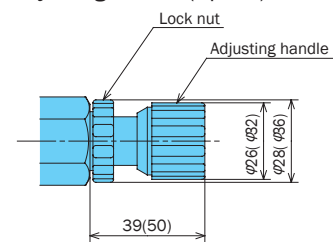

Performance Curves

Hydraulic Operating Fluid Viscosity 32 centistokes

Pressure - Flow Rate Characteristics

Setting Pressure - Drain Flow Rate Characteristics

GR-G01-A*-20

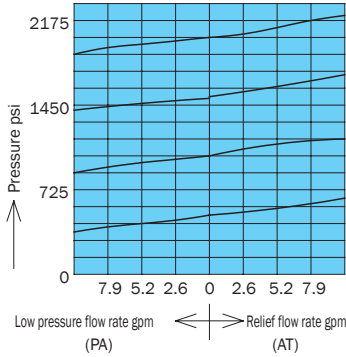

GR-G03-A*-(B)-20

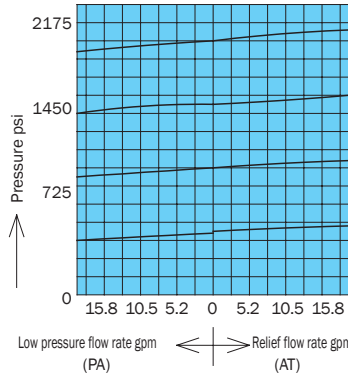

GR-G01-A*-20 ①
GR-G03-A*-(B)-20 ②

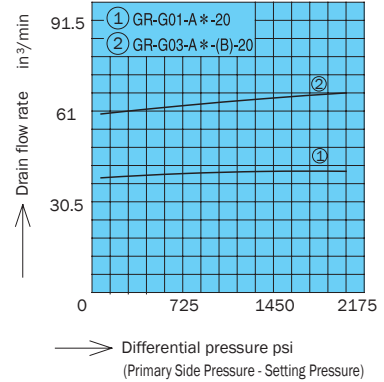

Cross-sectional Drawing

Note: O-ring 1A/B-** refers to JIS B2401- 1A/B-**.

GR-G01-A*-20

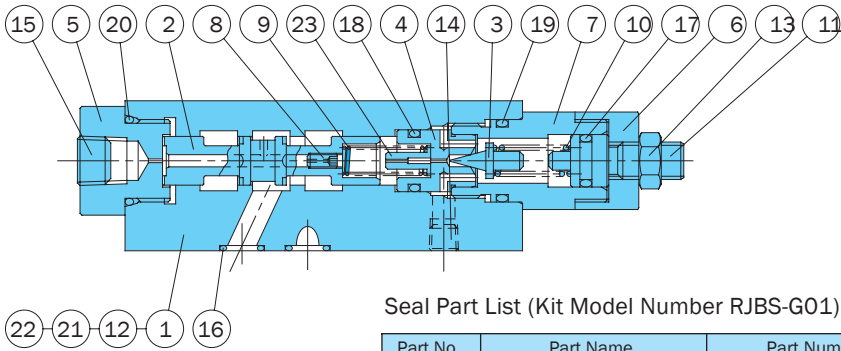

Seal Part List (Kit Model Number RJBS-G01)

Part No.	Part Name	Part Number	Q'ty
16	O-ring	1B-P9	4
17	O-ring	1A-P10A	1
18	O-ring	1B-P12.5	1
19	O-ring	1B-P18	1
20	O-ring	1B-P20	1

Part No.	Part Name	Part No.	Part Name
1	Body	7	Retainer
2	Spool	8	Choke
3	Poppet	9	Spring
4	Seat	10	Spring
5	Bushing	11	Screw
6	Bushing	12	Plate
		13	Nut
		14	Plug
		15	Plug
		16	O-ring
		17	O-ring
		18	O-ring
		19	O-ring
		20	O-ring
		21	Plug
		22	Spacer
		23	Choke

GR-G03-A*-B-20

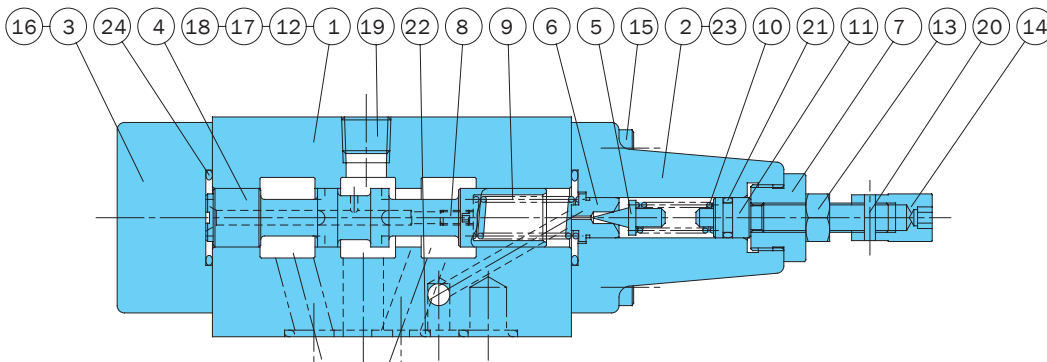

Seal Part List (Kit Model Number RJBS-G03)

Part No.	Part Name	Part Number	Q'ty
21	O-ring	1A-P8	1
22	O-ring	1B-P12	5
23	O-ring	1B-P9	1
24	O-ring	1B-P22	2

Part No.	Part Name
1	Body
2	Cover (A)
3	Cover (B)
4	Spool
5	Poppet
6	Seat
7	Retainer
8	Choke
9	Spring
10	Spring
11	Screw
12	Plate
13	Nut
14	Nut
15	Screw
16	Screw
17	Plug
18	Plug
19	Plug
20	Pin
21	O-ring
22	O-ring
23	O-ring
24	O-ring

Pressure Control (and Check) Valve

13.2 to 73.9 gpm
2030 psi

Features

This circuit control valve works as a sequence valve, unloading valve, and counter balance valve.

Maximum operating pressure is 3045 psi. Though a direct type valve, there is little pressure override.

The mounting surface of the gasket conforms to the ISO standards shown in the table below.

Specifications

Model No.		Nominal Diameter (Size)	Maximum Working Pressure psi	Maximum Flow Rate gpm	Pressure adjustment range psi	Weight lbs		Gasket Surface Dimensions
Screw Mounting	Gasket Mounting					T Type	G Type	
(C)Q-T03-*A-21 B C D E	(C)Q-G03-*A-21 B C D E	3/8	3045 IN, OUT, PP Ports	13.2	Type A 36 to 123	6.3	7.7	ISO 5781-AG-06-2-A
					Type B 72 to 253			
(C)Q-T06-*A-21 B C D E	(C)Q-G06-*A-21 B C D E	3/4					Type C 123 to 507	
					Type D 253 to 1015			
(C)Q-T10-*A-21 B C D E	(C)Q-G10-*A-21 B C D E	1 1/4			Type E 507 to 2030	21.6	25.3	ISO 5781-AJ-10-2-A

Weight values in parentheses are for when a check valve is included. The cracking pressure of the check valve is 14.5 psi.

Example circuit 1
When using type 2.

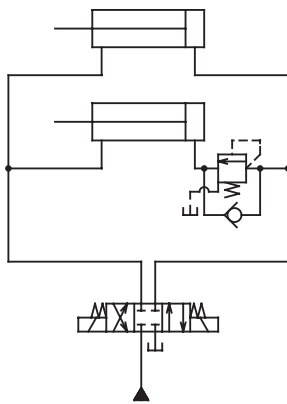

Example circuit 2
When using type 3.

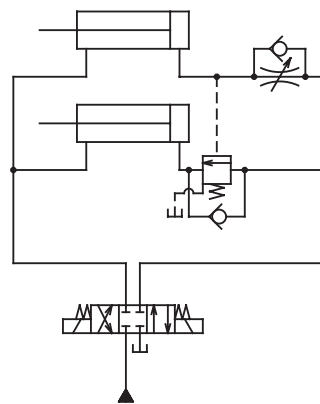

Understanding Model Numbers

(C)Q - G 10 - 1 B - 21

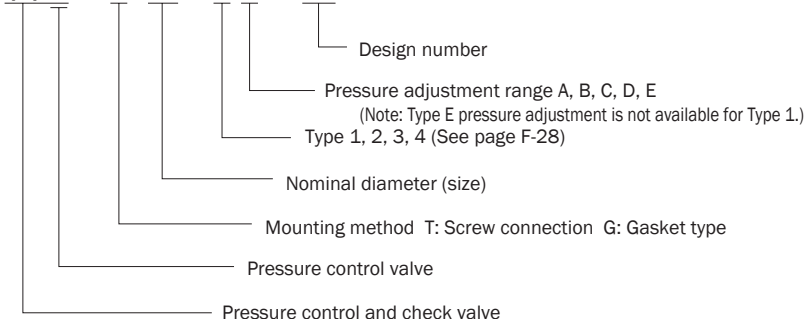

- Handling
- 1 To adjust pressure, loosen the lock nut and then rotate the adjusting bolt clockwise (rightward) to increase pressure or counterclockwise (leftward) to decrease it.
- 2 The pressure adjustment range is expressed in terms of cracking pressure.
- 3 Run the out port of Q-T/G** type 1 and 4 directly to the tank.
- 4 The following describes the method for using Types 2 and 3. Application of back pressure to the valve output side such as in the example circuit shown below, use Type 2 or Type 3 and run the drain port directly to the tank.
- 5 When two or more of these valves are ganged in sequence, make sure the setting pressure (cracking pressure) differential between them is at least 145 psi.
- 6 Vibration (chattering) may occur with the (C) Q-***-1E-21 depending on operating conditions when using type 1 and pressure adjustment range E. Use external drain type 2E if it happens.
- 7 Type 2 is standard. When Type 1, 3, or 4 is required, make modifications in accordance with the figures on the next page. Modifications change the valve type, so be sure to change the markings on the nameplate.
- 8 Use the following table for specification when a sub plate is required.

Model No.	Pipe Diameter	Weight lbs	Applicable Valve Model
MG-03-20	3/8	3.5	(C)Q-G03-**-21
MG-03X-20	1/2		
MG-06-20	3/4	8.5	(C)Q-G06-**-21
MG-06X-20	1		
MG-10-20	1 1/4	14.7	(C)Q-G10-**-21
MG-10X-20	1 1/2		

Note: These sub plates can also be used for reducing valves.

The following are the bundled mounting bolts.

Model No.	Bolt Dimensions	Qty	Tightening Torque ft lbs
(C)Q-G03-**-21	M10 × 75	4	33 to 40
(C)Q-G06-**-21	M10 × 85	4	
(C)Q-G10-**-21	M10 × 105	6	

Note: For mounting bolts, use 12T or equivalent.

Performance Curves

Q-***-**-21

CQ-***-**-21

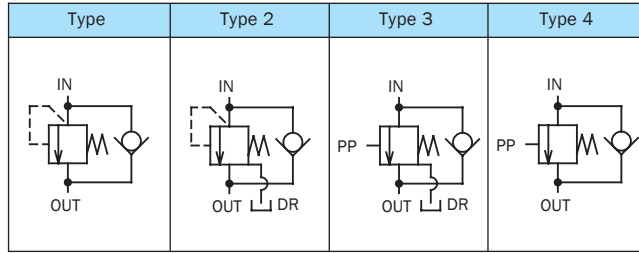
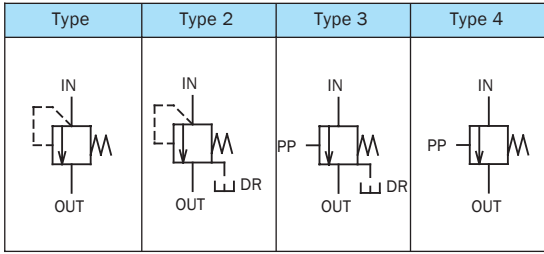

Type 2 is standard.

Installation Dimension Drawing

Q-T**-2*-21 (Screw Mounting)

Type 1

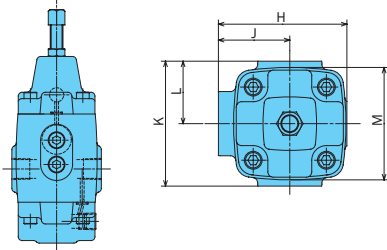

Type 3

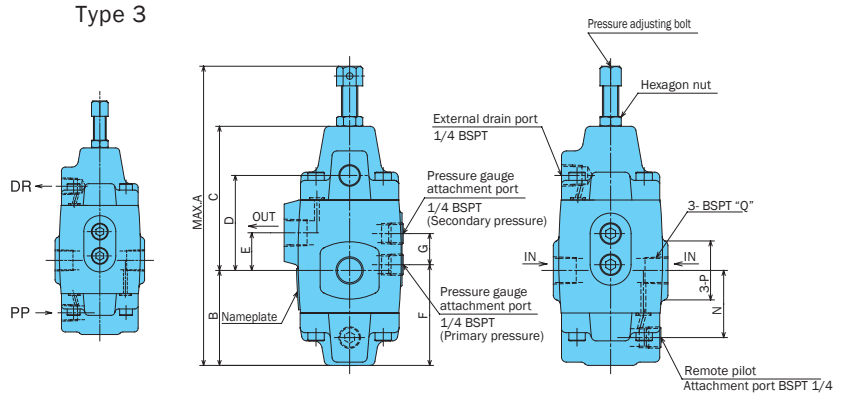

Type 4

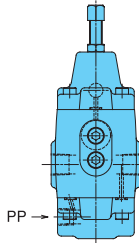

Model No.	A	B	C	D	E	F	G	H	J	K	L	M	N	P	Q
(C)Q-T03-**-21	179.5	58	88	58	23	61.5	19	72	40	70	35	63	41	36	3/8
(C)Q-T06-**-21	204.5	69.5	101.5	71.5	27	85	24	87	50	95	47.5	73	52.5	54	3/4
(C)Q-T10-**-21	251	83.5	132.5	87.5	28	89	30	116	68.5	108	54	95	62.5	69	1 1/4

Q-G**-2*-21 (Gasket Mounting)

Type 1

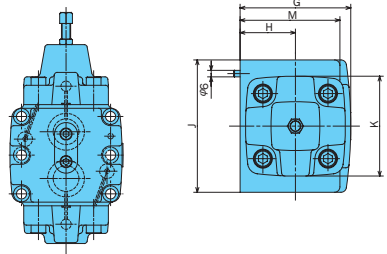

Type 3

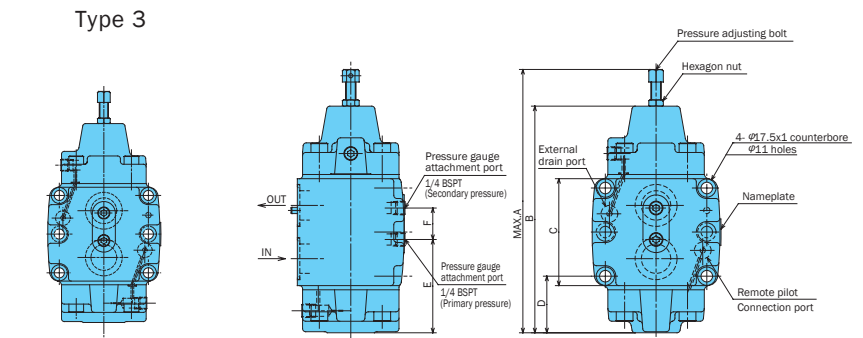

Type 4

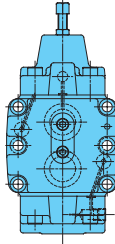

Model No.	A	B	C	D	E	F	G	H	J	K	L	M
Q-G03-**-21	179.5	146	62	45.1	61.5	19	72	35	88	60	4	60
Q-G06-**-21	204.5	171	82	51.4	75	24	80	40	102	70	4	70
Q-G10-**-21	251	216	102	54	89	30	102	51	122	92	6	92

Proportional Valves

Installation Dimension Drawing

CQ-T**-2*-21 (Screw Mounting)

Type 1

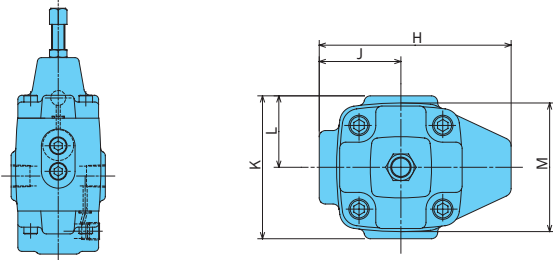

Type 3

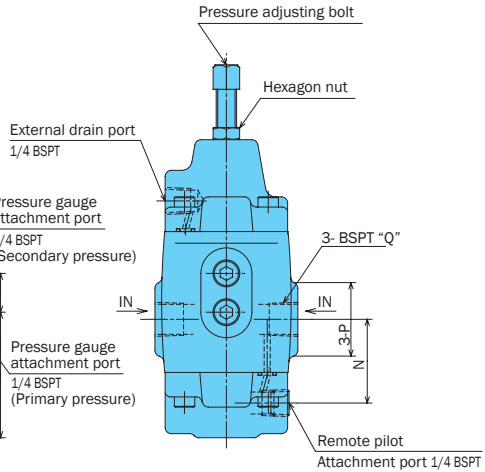
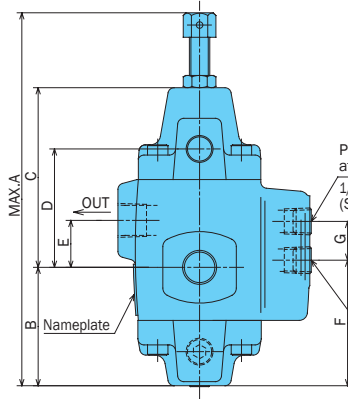
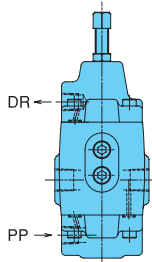

Type 4

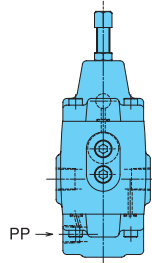

Model No.	A	B	C	D	E	F	G	H	J	K	L	M	N	P	Q
CQ-T03**-21	179.5	58	88	58	23	61.5	19	94	40	70	35	63	41	36	3/8
CQ-T06**-21	204.5	69.5	101.5	81.5	27	75	24	110	50	95	47.5	73	52.5	54	3/4
CQ-T10**-21	251	83.5	132.5	87.5	28	89	30	148.5	68.5	108	54	95	62.5	69	1 1/4

CQ-G**-2*-21 (Gasket Mounting)

Type 1

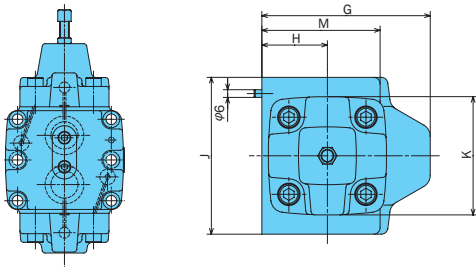

Type 3

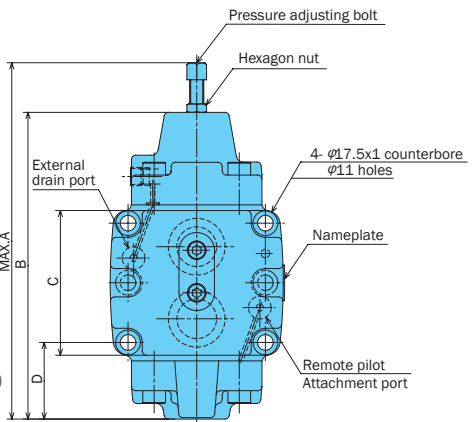
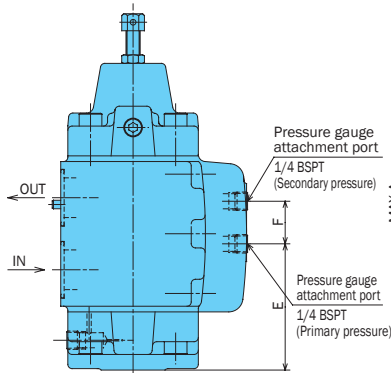
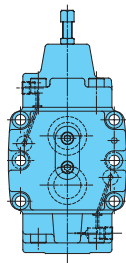

Type 4

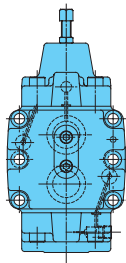

Model No.	A	B	C	D	E	F	G	H	J	K	L	M
CQ-G03**-21	179.5	146	62	45.1	61.5	19	89	35	88	60	4	60
CQ-G06**-21	204.5	171	82	51.4	75	24	100	40	102	70	4	70
CQ-G10**-21	251	216	102	54	89	30	131	51	122	92	6	92

Sub Plate MG-***-20

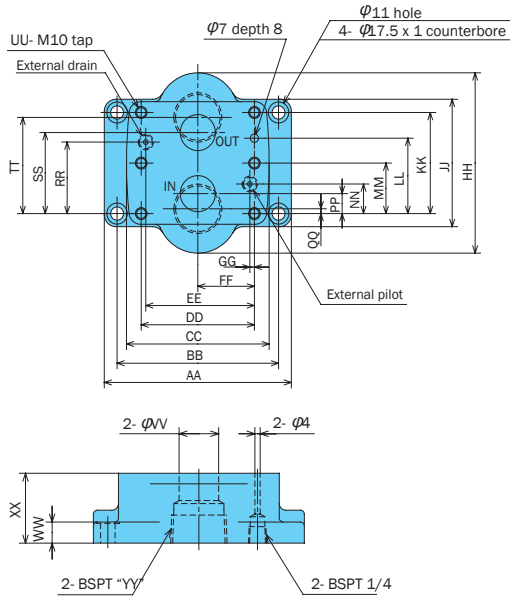

Note 1: The figure shows size 10(X), with four M10 tap holes for size 03(X) and 06(X) valve mounting bolts.
 Note 2: When a valve cover external drain and external pilot port are used, remove the plugs from the sub plate external drain and external pilot port.

Model No.	AA	BB	CC	DD	EE	FF	GG	HH	JJ	KK	LL	MM	NN	PP	QQ	RR	SS	TT	UU	VV	WW	XX	YY
MG-03-20	128	106.4	88	66.6	58.7	33.3	7.9	76	62	42.9	31.8	-	21.4	7.2	3.5	21.4	35.7	39.5	4	14	11	30	3/8
MG-03X-20																							1/2
MG-06-20	160	123.8	102	79.3	72.9	39.7	6.4	110	82	60.3	44.5	-	20.6	11.1	3.7	39.7	49.2	56.7	4	22	16	40	3/4
MG-06X-20																							1
MG-10-20	160	138.1	122	96.8	92.9	48.4	3.9	150	102	84.1	62.7	42.1	24.6	16.7	4.1	59.5	67.5	80.1	6	30	16	53	1 1/4
MG-10X-20																							1 1/2

Performance Curves

Hydraulic Operating Fluid Viscosity 32 centistokes

Pressure Loss Characteristics

(C)Q-T03-***-21

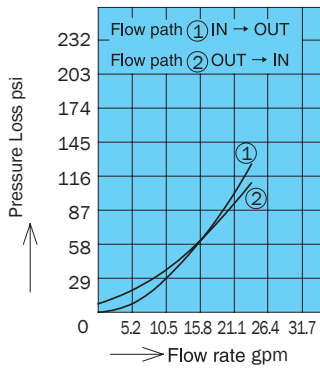

(C)Q-T06-***-21

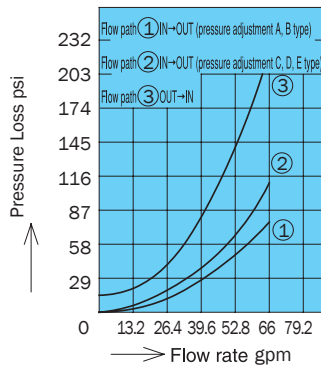

(C)Q-T10-***-21

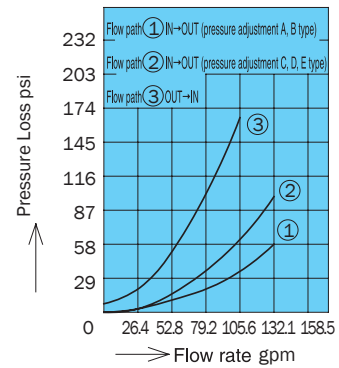

(C)Q-G03-***-21

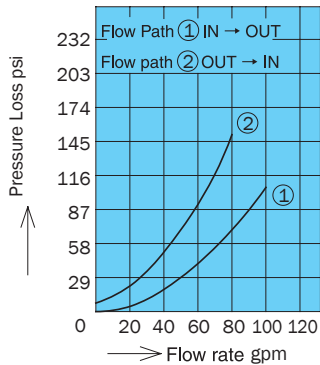

(C)Q-G06-***-21

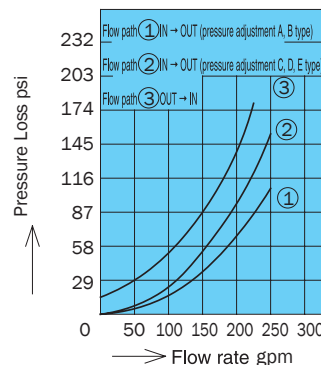

(C)Q-G10-***-21

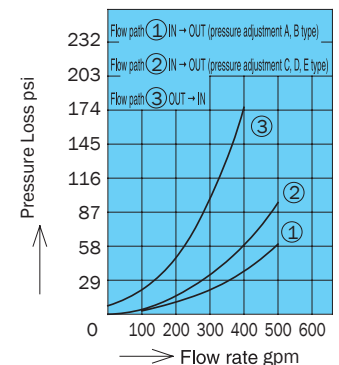

Pressure - Flow Rate Characteristics

(— : Press rise
 - - - : Pressure drop)

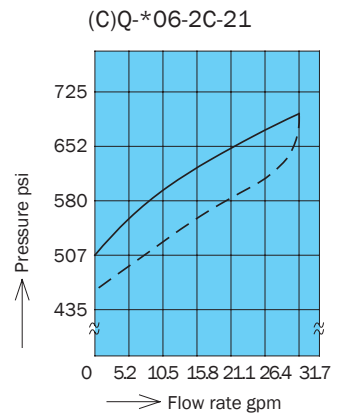
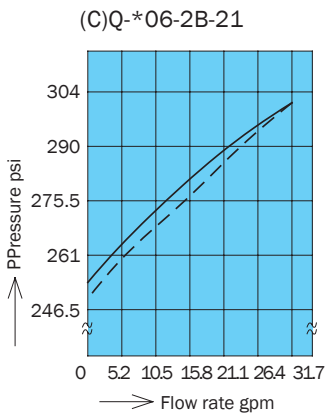
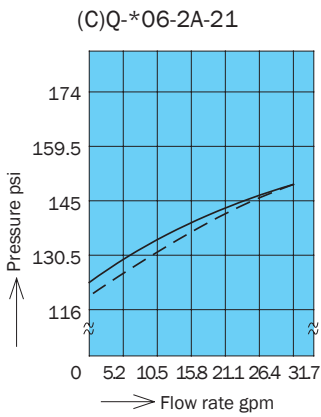
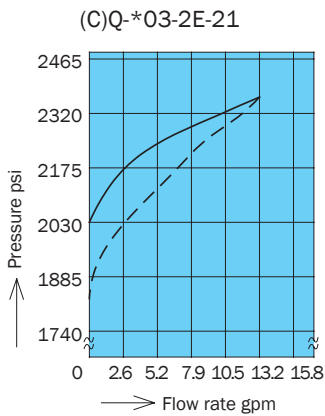
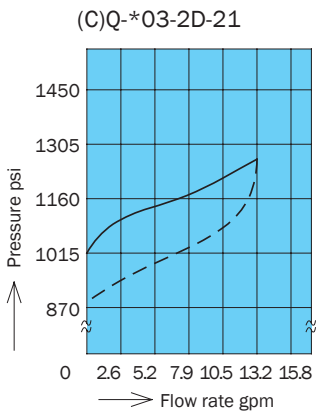
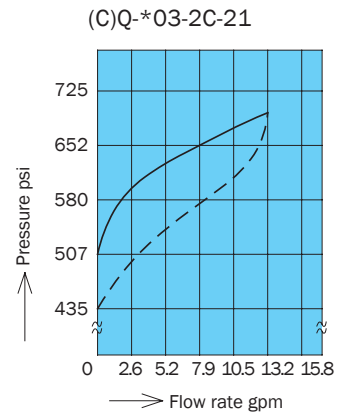
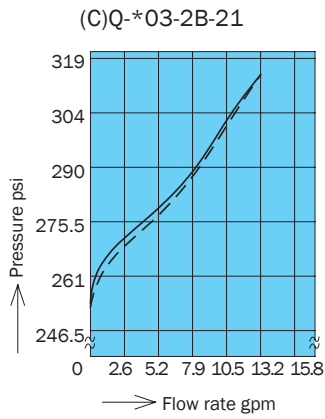
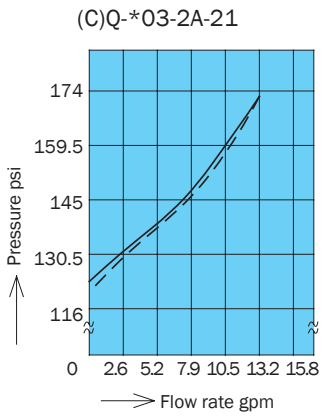

Pressure - Flow Rate Characteristics

(— : Press rise
 - - - : Pressure drop)

(C)Q-*06-2D-21

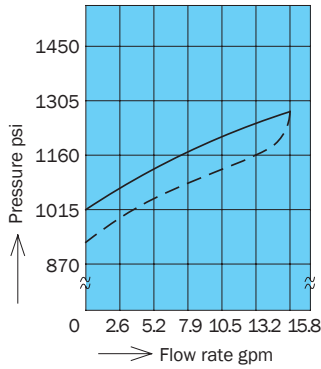

(C)Q-*06-2E-21

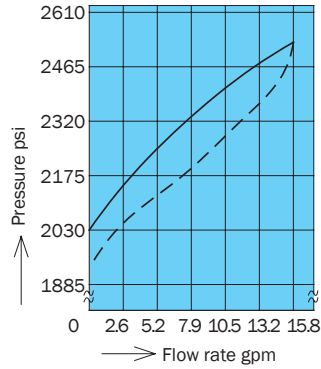

(C)Q-*10-2A-21

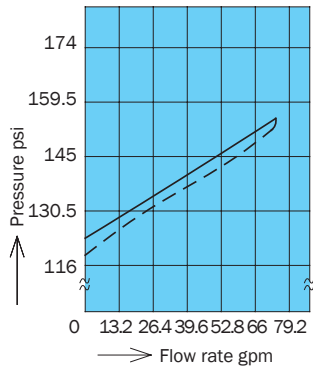

(C)Q-*10-2B-21

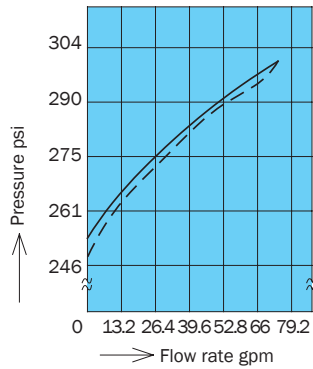

(C)Q-*10-2C-21

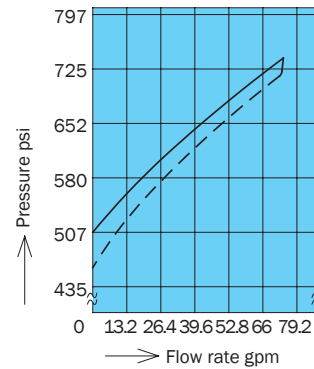

(C)Q-*10-2D-21

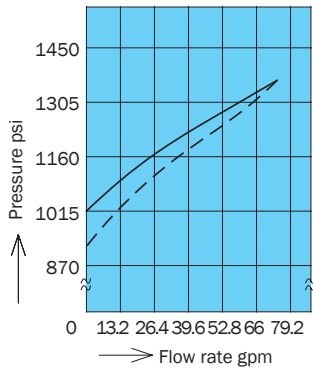

(C)Q-*10-2E-21

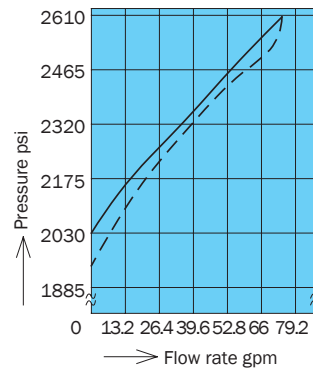

CQ-G***-21

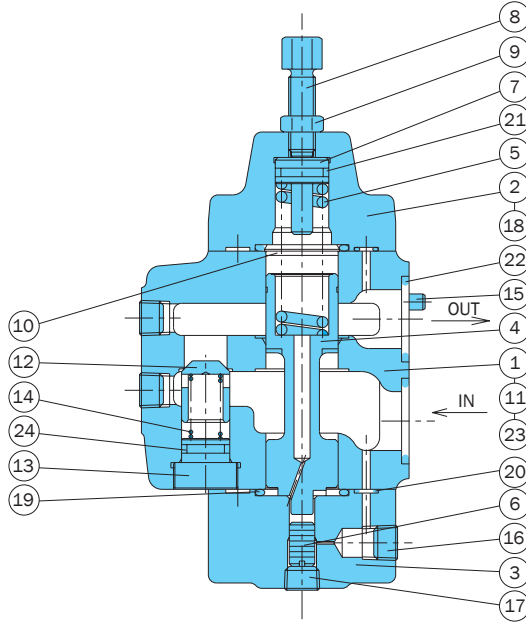

Part No.	Part Name
1	Body
2	Cover
3	Cover
4	Piston
5	Spring
6	Plunger
7	Push rod
8	Screw
9	Nut
10	Spacer
11	Nameplate
12	Poppet
13	Spring guide
14	Spring
15	Pin
16	Plug
17	Plug
18	Screw
19	O-ring
20	O-ring
21	O-ring
22	O-ring
23	O-ring
24	O-ring

Note: The illustration shows the configuration for pressure adjustment ranges Type C, Type D, and Type E. For Type A and Type B, the #6 piston is eliminated, and the #4 spool and #5 spring are different.

Note: Part numbers 12, 13, 14, and 24 are not required when there is no check valve.

Seal Part List (Kit Model Number RQBS-***(C))

Part No.	Part Name	Type/Part Number						Q'ty
		CQ-G03-**-21	CQ-T03-**-21	CQ-G06-**-21	CQ-T06-**-21	CQ-G10-**-21	CQ-T10-**-21	
19	O-ring	1B-P22	1B-P22	1B-G30	1B-G30	1B-P40	1B-G40	2
20	O-ring	1B-P6	1B-P6	1B-P6	1B-P6	1B-P6	1B-P6	4
21	O-ring	1B-P11	1B-P11	1B-P16	1B-P16	1B-P22A	1B-P22A	1
22	O-ring	1B-P20	-	1B-P26	-	1B-G35	-	2
23	O-ring	1B-P12	-	1B-P12	-	1B-P12	-	2
24	O-ring	1B-P11	1B-P11	1B-P14	1B-P14	1B-P22	1B-P22	1

Note: O-ring 1B-** refers to JIS B2401-1B-**.

For the *** part of the kit number, specify the valve size (G03, T06). To specify inclusion of a check valve, add C to the end.