



2019 PRODUCT CATALOG



BLADDER | PISTON | DIAPHRAGM

Houston, Texas, USA
Established 1987

An ISO-9001 Company

The information contained in this catalog is for the exclusive use of our customers. Assigned stocking distributors may reproduce all or any portion of this catalog for internal use or for the promotion of our products. Permission for other customers must be requested and granted in writing from the Accumulators, Inc. Sales department. All information in this catalog is copyrighted by Accumulators, Inc. The Accumulators, Inc. name and logo, AccuMight name and logo, Acc Inc, ACCINC and accumulators, accumulators.com and variations, are all registered Trademarks and Service Marks of Accumulators, Inc. As with all hydraulic products, the correct selection, installation, operation and maintenance of accumulators by qualified personnel is solely the user's responsibility. ALL WARRANTIES, EXPRESS OR IMPLIED, OF MERCHANTABILITY OR FITNESS FOR A PARTICULAR PURPOSE, WITH RESPECT TO ANY LISTED OR PURCHASED PRODUCT(S), ARE EXPRESSLY EXCLUDED AND DISCLAIMED BY ACCUMULATORS, INC. Accumulators, Inc. is not responsible for typographical errors.

CONTACTING US

Phone: 713-465-0202
Fax: 713-468-1618
Web: accumulators.com
Email: info@accumulators.com

WORLD HEADQUARTERS

18435 Morton Road
Houston, TX 77084

To download this catalog, to use our online tools (accumulator sizing, elastomer compatibility, and part number cross reference), and to check for contact information updates, please visit our website at accumulators.com

CONTENTS	1
Contact and Location Information	1
Product Overview	2
BLADDER ACCUMULATORS	3
Bladder Accumulators Overview	4
Bladder Accumulator Ordering Table	5
Bladder Accumulator Specifications	6
Transfer Barrier Accumulators	7
High-Flow Accumulators	8
Bladder Material Specifications	9
Bladders & Bladder Kits	10
Gas Valves & Bladder Valve Stems	11
Fluid Port Assemblies	12
Mounting Collars	13
Mounting Bases	14
Mounting U-Bolts	15
Charging & Gauging Kits and Assemblies	16
Permanent Mount Pressure Monitors	19
Maintenance Kits	20
Tools	21
Safety Blocks	22
Nitrogen Gas Booster Packages	23
Bladder Kit Storage & Care	24
Special Order Bladder Accumulators	25
PISTON ACCUMULATORS	27
Piston Accumulator Overview	28
Piston Accumulator Ordering Table	29
Piston Accumulator Specifications	30
Mounting Collars	32
DIAPHRAGM ACCUMULATORS	33
Diaphragm Accumulator Overview	34
Diaphragm Accumulator Ordering Table	35
Diaphragm Accumulators	36
Welded Diaphragm Accumulators	37
Mounting Collars	38
SPECIALTY ACCUMULATOR PRODUCTS	39
Gas Storage Bottles	40
Seamless Dual-Port Gas Bottles	41
Float Accumulators	42
ENGINEERING, SERVICE, SUPPORT, TRAINING	43
Custom Engineering & Fabrication	44
Hazmat & D.O.T. Exemption	45
Training	46
Frequently Asked Questions	47
TERMS & CONDITIONS AND WARRANTY	51
INDEX	55

PRIMARY ACCUMULATOR OPTIONS

CATALOG OVERVIEW

Established in 1987 and located in Houston, Texas, Accumulators, Inc.® is the technological leader for all types of accumulators. Why do our customers rate us so highly? We consistently deliver the correct product quickly and on-time, and we will do the same for you! We are your accumulator specialists.

Our accumulators and related products are useful in many industries including but not limited to:

Oil Field and Petro-Chemical
Ground Support and Agriculture
Entertainment Simulators
Manufacturing
Renewable Energy Generation

Defense and Maritime
Aerospace and Transport
Machine Tools
Rubber and Plastics Manufacturing
Mining

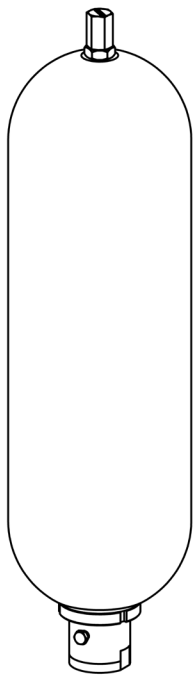

BLADDER ACCUMULATORS

Bladder accumulators are easily field repairable and have a high tolerance for contamination; perfect for offshore applications. We offer standard sizes ranging up to 40 gallons capacity at 3,000 PSI, and up to 15 gallons capacity at 6,000 and 10,000 PSI.

Available with carbon steel, stainless steel, or carbon-fiber wrapped shells and a wide variety of protective coatings.

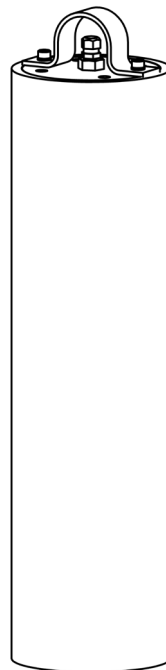

PISTON ACCUMULATORS

Piston accumulators are highly-customizable and can offer much larger volumes and higher pressures and temperatures than many bladder accumulators. Additionally, a wider tolerance for the initial precharge setting allows for a higher fluid-to-gas ratio necessary for certain applications. We can manufacture any required piston accumulator for your application. Several sizes are available from stock.

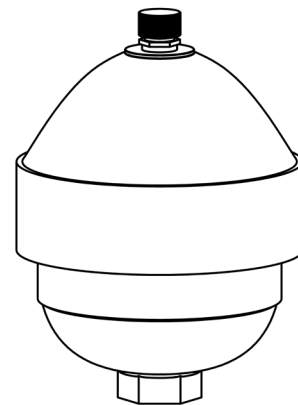

DIAPHRAGM ACCUMULATORS

Diaphragm accumulators provide a great deal of energy in a small space. They have a high tolerance for contamination and are perfect for pulsation dampening, off road equipment and other small-flow applications.

Available up to 150 in³ capacity at 3,000 PSI and 45 in³ capacity at 5,000 PSI. We offer both welded and field-repairable versions.



BLADDER ACCUMULATORS



Visit accumulators.com for more information.

OVERVIEW

BLADDER ACCUMULATORS



Our standard bladder accumulator consists of a molded rubber bladder inside a forged steel shell with a nitrogen gas valve on one end and a fluid port at the other. The flexible bladder provides excellent separation between the fluid and gas in the accumulator, while the seamless shell reduces leak points. Additionally, our design ensures the accumulator cannot be disassembled while under pressure. Before typical use, the bladder must be charged with a calculated pressure of nitrogen gas as determined by the application requirements. As system pressure changes, the nitrogen-charged bladder expands or contracts within the shell, allowing the accumulator to discharge or absorb fluid from the system as necessary. All of our bladder accumulators are ASME code stamped.

Bladder accumulators are durable and efficient and have a wide variety of applications such as blowout preventer systems, pulsation dampening, hydraulic power units, fluid volume compensation, wind energy, and many other industrial applications.

Bladder accumulators have several advantages over other types of accumulators:

- Rapid response to pressure changes and work cycle
- Complete separation of gas and fluid
- Highly resistant to fluid contamination
- Low maintenance, trouble-free operation
- Readily available, low cost replacement parts
- Eliminates costly down time on expensive systems due to simple repair

PARTS, ACCESSORIES & TOOLS		MAINTENANCE & SELECTION		ENGINEERING, SERVICE & TRAINING	
Accumulators	6	Ordering Table	5	Custom Engineering	44
Bladders	10	FAQ	47	Hazmat & D.O.T.	45
Gas Valves	11			Training Services	46
Fluid Port Assemblies	12				
Mounting Equipment	13				
Charging & Gauging	16				
Tools & Tool Kits	20				
Safety Blocks	22				
Nitrogen Gas Boosters	23				
Gas Bottles	40				

BLADDER ACCUMULATOR ORDERING TABLE

BLADDER ACCUMULATORS

Use the table below to determine the part number for your desired accumulator. For help sizing your accumulator, selecting a compatible elastomer, and to obtain a quote on accumulators and all our other products, visit our website at accumulators.com

Select the desired option from each list and place the corresponding code in its proper place:

APPROVAL CODE	SIZE	MODEL	PRESSURE	FLUID PORT	BLADDER	SERVICE	EXAMPLE
A	15		3100	3		NP	= A1531003NP

APPROVAL CODE		MODEL		1 PINT & 1 QUART FLUID PORTS		BLADDER	
OPTION	CODE	OPTION	CODE	OPTION	CODE	OPTION	CODE
Standard (ASME)	A	Bottom Repairable	Blank	3/4" NPT	Blank	Buna-Nitrile	Blank
DNV	N	Top Repairable	TR	1 1/16"-12 SAE #12 ORB	3	Butyl	B
ABS	B	Float	F	Code 61, 3/4" SAE Split Flange (1 QT only)	4	EPR	E
CE	P	High Flow	H	1 & 1.5 GAL FLUID PORTS		Extreme Low-Temp Buna	X
CRN	R	High Flow, Top Repairable	HT	OPTION		Fluorocarbon	V
ABS & DNV	D	Transfer Barrier	TB?*	1 1/4" NPT	Blank	Hydrin/ECO	H
ABS, DNV & NR13	DJ	PRESSURE		1 5/8"-12 SAE #20 ORB	3	Low-Temp Buna	L
SIZE		OPTION		Code 61, 1.5" SAE Split Flange	4	SERVICE	
OPTION		CODE		2.5-15 GAL FLUID PORTS		OPTION	
1 Pint	1PT	2000 PSI	2100	OPTION		CODE	
1 Quart	1QT	3000 PSI	3100	2" NPT	Blank	Oil Service	Blank
1 Gallon	1	4000 PSI	4100	1 1/4" NPT	1	Water Service	WS
1.5 Gallon	1.5	5000 PSI	5100	1-7/8"-12 SAE #24 ORB	3	Chemical Service	PS
2.5 Gallon	2.5	6000 PSI	6100	Code 61, 2" SAE Split Flange (3000 PSI)	4	Nickel Plated	NP
5 Gallon	5	10000 PSI	10100	Code 62, 1.5" SAE Split Flange (6000 PSI)	4	Extreme Service	XS
10 Gallon	10			Code 62, 1.5" SAE Split Flange Extended Neck	15	Economy Service	CS
11 Gallon	11			Code 62, 1.5" SAE Split Flange; Seal Sub, Male	98	All Stainless	AS
15 Gallon	15						
40 Gallon	40						

* ?=Letter code for coupler options, see page 7.

Only the most popular options are shown above. We have many more options and products available.

BLADDER ACCUMULATORS

1 PT - 40 GAL 3000 | 6000 | 10000 PSI

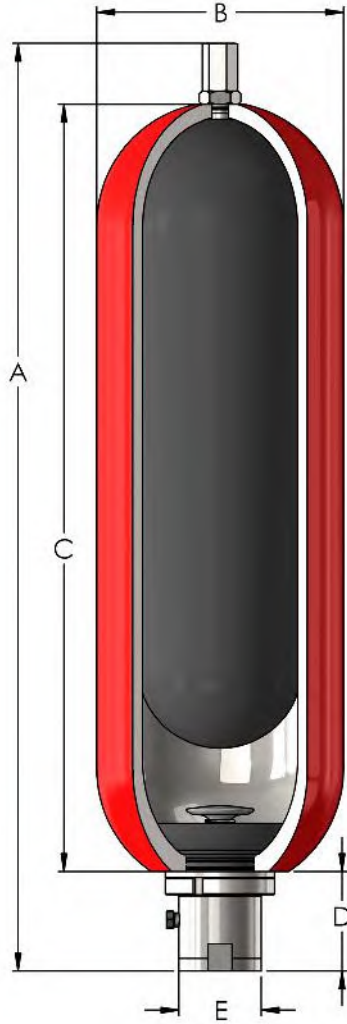

For standard options, see our ordering table on page 5.

3000 PSI MODELS

PART	PART (TR)	NOMINAL SIZE (GAL)	GAS VOLUME (IN ³)	DIMENSIONS (IN.)					WEIGHT (LBS.)	WEIGHT (TR)
				A	B	C	D	E		
A1PT3100	-	0.12	28	9.9	3.5	6.5	1.9	1.4	6	-
A1QT3100	-	0.25	49	12.0	4.5	7.6	2.1	1.4	10	-
A13100	-	1	214	17.0	6.7	11.0	3.5	2.4	32	-
A1.53100	-	1.5	328	21.5	6.6	15.8	3.5	2.4	41	-
A2.53100	A2.5TR3100	2.5	536	21.0	9.0	15.5	3.5	3.0	76	78
A53100	A5TR3100	5	1106	33.0	9.0	27.5	3.5	3.0	116	118
A103100	A10TR3100	10	2101	54.0	9.0	48.5	3.5	3.0	212	214
A113100	A11TR3100	11	2359	60.0	9.0	54.0	3.5	3.0	230	232
A153100	A15TR3100	15	3165	78.0	9.0	72.0	3.5	3.0	296	298
-	A40TR3100	40	9240	93.0	14	87.8	5.1	4.3	-	780

5000 & 6000 PSI MODELS

PART	PART (TR)	NOMINAL SIZE (GAL)	GAS VOLUME (IN ³)	DIMENSIONS (IN.)					WEIGHT (LBS.)	WEIGHT (TR)
				A	B	C	D	E		
A1QT5100	-	0.25	49	12.0	4.7	7.6	2.1	1.4	12	-
A16100	-	1	214	18.0	7.2	11.4	3.5	2.4	36	-
A2.56100	A2.5TR6100	2.5	536	22.0	9.6	15.5	3.9	3.0	118	120
A56100	A5TR6100	5	1106	34.0	9.6	27.5	3.9	3.0	198	200
A106100	A10TR6100	10	2101	55.0	9.6	48.5	3.9	3.0	308	310
A156100	A15TR6100	15	3165	79.0	9.6	72.0	3.9	3.0	468	470

10000 PSI MODELS

PART	NOMINAL SIZE (GAL)	GAS VOLUME (IN ³)	DIMENSIONS (IN.)					WEIGHT (LBS.)
			A	B	C	D	E	
A2.510100XS	2.5	496	25.0	11.75	17.0	3.5	3.0	325
A510100XS	5	1065	37.0	11.75	29.0	3.5	3.0	515
A1010100XS	10	2060	58.0	11.75	50.0	3.5	3.0	850
A1510100XS	15	3165	81.0	11.75	73.5	3.5	3.0	1225

Carbon steel standard. Also available in stainless steel, carbon fiber, and with a wide variety of protective coatings. Contact us for more information.



TOP REPAIRABLE (TR) OPTION

TRANSFER BARRIER ACCUMULATORS

1QT - 15 GAL 3000 | 6000 PSI

For standard options, please see our ordering table on page 5.

3000 PSI TRANSFER BARRIER MODELS

PART	NOMINAL SIZE (GAL)	GAS VOLUME (IN ³)	DIMENSIONS (IN.)					WEIGHT (LBS.)
			A	B	C	D	E	
A1QTTBF3100	0.25	49	12.0	4.5	7.6	2.1	1.6	10
A1TBF3100	1	214	18.0	6.7	11.0	3.5	2.4	32
A1.5TBF3100	1.5	328	22.5	6.6	15.8	3.5	2.4	41
A2.5TBF3100	2.5	536	22.0	9.0	15.5	3.5	3.0	78
A5TBF3100	5	1106	34.0	9.0	27.5	3.5	3.0	118
A10TBF3100	10	2101	55.0	9.0	48.5	3.5	3.0	214
A11TBF3100	11	2359	61.0	9.0	54.0	3.5	3.0	232
A15TBF3100	15	3165	79.0	9.0	72.0	3.5	3.0	298

5000 & 6000 PSI TRANSFER BARRIER MODELS

PART	NOMINAL SIZE (GAL)	GAS VOLUME (IN ³)	DIMENSIONS (IN.)					WEIGHT (LBS.)
			A	B	C	D	E	
A1QTTBF5100	0.25	49	14.4	4.6	7.6	2.1	1.2	12
A1TBF6100	1	214	19.0	7.2	11.4	3.5	2.4	39
A2.5TBF6100	2.5	536	25.0	9.6	15.5	3.9	3.0	120
A5TBF6100	5	1106	37.0	9.6	27.5	3.9	3.0	200
A10TBF6100	10	2101	58.0	9.6	48.5	3.9	3.0	310
A15TBF6100	15	3165	82.0	9.6	72.0	3.9	3.0	470

TRANSFER BARRIER COUPLER OPTIONS

COUPLER OPTIONS

PART NUMBER	DESCRIPTION
AI-TB-321-C	3/4" NPT
AI-TB-321-E	1 1/4" NPT
AI-TB-321-F	1/2" NPT x 3
AI-TB-321-G	1/4" NPT
AI-TB-321-O	3/4"-16 SAE
AI-TB-321-Q	7/16" SAE
AI-TB-321-R	1 1/16" SAE
AI-TB-321-X	3/8" Medium Pressure x 3
AI-TB-321-Z	1/4" NPT x 1/2" NPT
AI-TB-321-AC	1/4" Medium Pressure

For accumulator ordering purposes, use the letter code after the last hyphen, for example A5TBF3100 or A5TBG3100.

316 SS FLUID STRAINERS

Used primarily as a seawater strainer for subsea compensators. Typically attaches to the fluid port of a transfer barrier accumulator. Also available in copper.



PART	THREAD
AI-S-440-SS	3/4" NPT
AI-S-441-SS	2" NPT
AI-S-442-SS	1-1/4" NPT
AI-S-444-SS	1" NPT

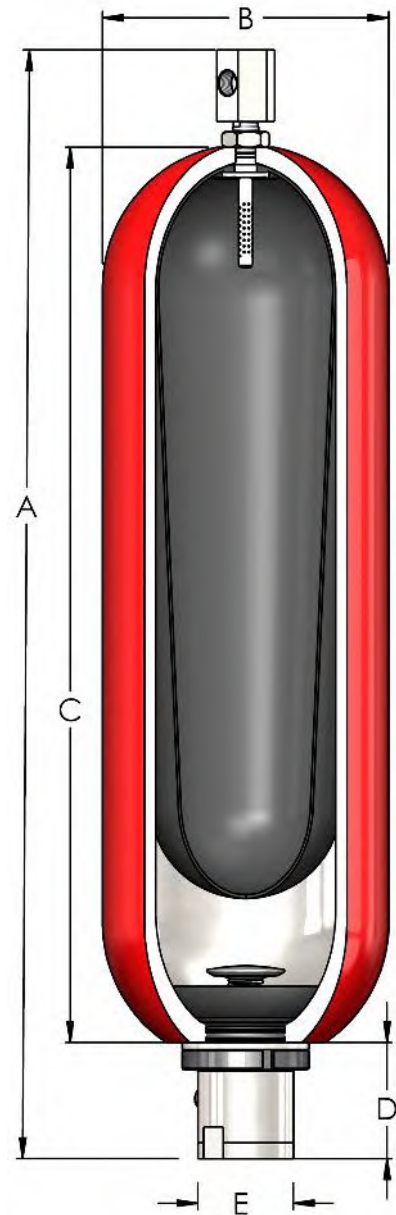

HIGH-FLOW BLADDER ACCUMULATORS

2.5 - 15 GAL 3000 PSI

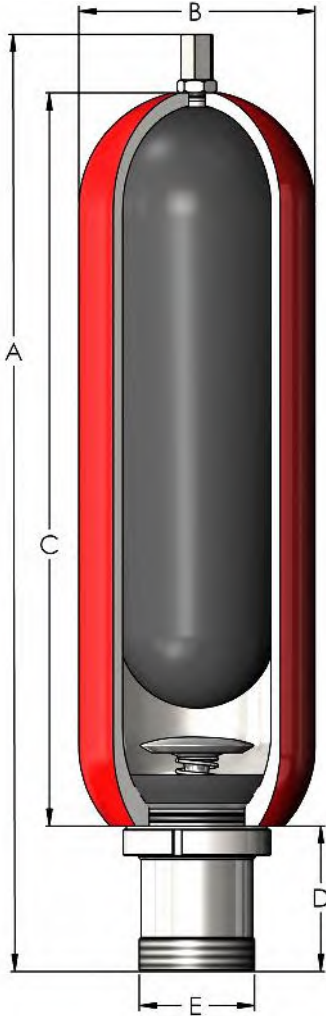

Designed for applications that require a fluid transfer rate of 200-600 GPM.

3000 PSI MODELS

PART	TOP REPAIRABLE	NOMINAL SIZE (GAL)	GAS VOLUME (IN ³)	DIMENSIONS (IN.)					WEIGHT (LBS.)	WEIGHT (TR)
				A	B	C	D	E		
A2.5H3100	A2.5HT3100	2.5	522	24.0	9.0	16.0	5.6	4.4	78	80
A5H3100	A5HT3100	5	1092	36.0	9.0	28.0	5.6	4.4	118	120
A10H3100	A10HT3100	10	2087	57.0	9.0	49.0	5.6	4.4	214	216
A11H3100	A11HT3100	11	2345	63.0	9.0	55.0	5.6	4.4	230	232
A15H3100	A15HT3100	15	3208	81.0	9.0	73.0	5.6	4.4	296	298

FLUID PORT OPTIONS

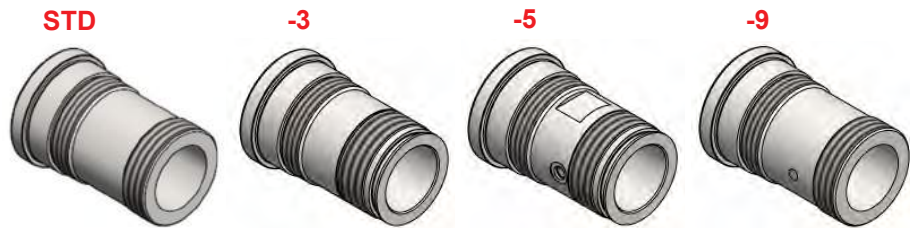

STANDARD HIGH-FLOW FLUID PORT OPTIONS

Std	4" -8 Male NPT
-3	4-1/4" -8 UN-2 Male SAE
-5	4-1/4" -8 UN-2 Male SAE, 9/16" -18 SAE Bleed
-9	4" -8 Male NPT, 1/4" -18 NPT bleed

BLADDER MATERIAL SPECIFICATIONS

BLADDER ACCUMULATORS - PARTS

BLADDER MATERIAL SPECIFICATIONS

The following chart is for typical applications at moderate cycles and is based on a combination of laboratory results and field testing. System fluid selection and contamination can significantly affect performance. Since real world usage can vary widely, ACC INC cannot guarantee the acceptability of any particular system or the expected life of an elastomer product.

The use of compatible clean fluids is highly recommended. Proper filtration is necessary. High temperature applications should use oil coolers. Low temperature applications require fluid that is in a liquid state.

BLADDER MATERIAL SPECIFICATIONS							
RUBBER COMPOUND	CODE	PEAK RANGE (F)	OPTIMAL RANGE (F)	PERMEABILITY	HARDNESS SHORE (A)	TENSILE (PSI)	ELONGATION (%)
BUNA-NITRILE	N/A	-10 TO 220	35 TO 160	.39	60	2000	400
LOW TEMP BUNA-NITRILE	L	-60 TO 200	-25 TO 145	2.05	50	1500	400
EXTREME LOW TEMP NITRILE	X	-80 TO 200	-25 TO 145	2.10	60	1500	400
BUTYL	B	-45 TO 200	35 TO 160	.22	60	1500	400
ETHYLENE-PROPYLENE (EPR)	E	-55 TO 330	35 TO 250	2.25	60	1500	400
FLUORO-ELASTOMER (FKM)	V	0 TO 350	35 TO 350	1.72	65	1300	400
HYDRIN/ECO	H	-40 TO 275	-	.23	60	1300	400

PEAK: Upper value is based on elastomer vendor data. Lower value is based on ASTM D-1053.

OPTIMAL: Based on good hydraulic practices. Extended operation beyond these temperatures may shorten the life of the bladder.

PERMEABILITY: Based on ASTM D-1434 at 73° F. Units x 10⁻⁸ cm²/sec • atm.

OTHER PHYSICAL PROPERTIES: Values are nominal and are based on laboratory results.

BLADDER ELASTOMER CAPABILITY

There are thousands of chemical compounds that have been tested with bladder elastomers. An up to date compatibility chart of the most popular fluids can be found on our website at www.accumulators.com/rubber-compatibility.html.

Please contact our sales department for additional assistance in determining the proper elastomer for your application.

BLADDERS & BLADDER KITS

BLADDER ACCUMULATORS - PARTS

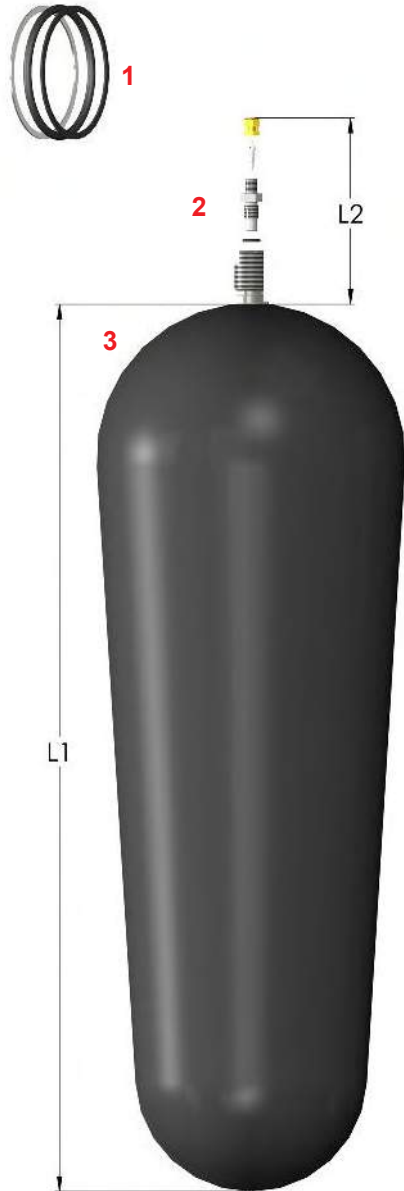

COMPONENT PARTS

- 1 Seal Rings
- 2 Gas Valve*
- 3 Bladder

*3000 PSI gas valve shown

3000 PSI BLADDER SPECIFICATIONS

SIZE (PART NO.)	L1 (IN)	L2 (IN)	STD. THREAD OD	WEIGHT (LBS)
1 Pint (AI-1PT-3KT)	5.25	1.7	5/8"-18 UNF	1
1 Quart (AI-1QT-3KT)	5.7	1.7	5/8"-18 UNF	1
150 CI (AI-150CI-3KT)	11	2.3	5/8"-18 UNF	1
1 Gallon (AI-1-3KT)	8	2.3	7/8"-14 UNF	1
1.5 Gallon (AI-1.5-3KT)	12.0	2.3	7/8"-14 UNF	1
2.5 Gallon (AI-2.5-3KT)	11.5	2.3	7/8"-14 UNF	2
5 Gallon (AI-5-3KT)	23	2.3	7/8"-14 UNF	4
10 Gallon (AI-10-3KT)	43.5	2.3	7/8"-14 UNF	6
11 Gallon (AI-11-3KT)	49.5	2.3	7/8"-14 UNF	7
15 Gallon (AI-15-3KT)	64	2.3	7/8"-14 UNF	8
40 Gallon (AI-40-3KT)	80	5	2"-12 UNF	25

5000 & 6000 PSI BLADDER SPECIFICATIONS

SIZE (PART NO.)	L1 (IN)	L2 (IN)	STD. THREAD OD	WEIGHT (LBS)
1 Quart (AI-1QT-5-3KT)	5.7	1.7	7/8"-14 UNF	1
1 Gallon (AI-1-6-3KT)	8	3.3	7/8"-14 UNF	1
2.5 Gallon (AI-2.5-6-3KT)	11.5	3.3	7/8"-14 UNF	2
5 Gallon (AI-5-6-3KT)	23	3.3	7/8"-14 UNF	4
10 Gallon (AI-10-6-3KT)	43.5	3.3	7/8"-14 UNF	6
15 Gallon (AI-15-6-3KT)	64	3.3	7/8"-14 UNF	8

10000 PSI BLADDER SPECIFICATIONS

SIZE (PART NO.)	L1 (IN)	L2 (IN)	STD. THREAD OD	WEIGHT (LBS)
2.5 Gallon (AI-2.5-10-3KT-SS)	11.5	5.2	2"-12 UNF	5
5 Gallon (AI-5-10-3KT-SS)	23	5.2	2"-12 UNF	7
10 Gallon (AI-10-10-3KT-SS)	43.5	5.2	2"-12 UNF	9
15 Gallon (AI-15-10-3KT-SS)	64	5.2	2"-12 UNF	11

GT TYPE 3000 & 5000 PSI BLADDER SPECIFICATIONS

SIZE (PART NO.)	L1 (IN)	L2 (IN)	STD. THREAD OD	WEIGHT (LBS)
2.5 Gallon (AI-2.5-GT5-3KT)	11.5	4.8	2"-12 UNF	6
5 Gallon (AI-5-GT5-3KT)	23	4.8	2"-12 UNF	8
10 Gallon (AI-10-GT5-3KT)	43.5	4.8	2"-12 UNF	10
15 Gallon (AI-15-GT5-3KT)	64	4.8	2"-12 UNF	12

For a list of available elastomers, see page 9.

ANTI-EXTRUSION RINGS*

PART NUMBER	SIZE
AI-1PT-407	1 PT, 3000 PSI
AI-1QT-407	1 QT, 3000 & 5000 PSI
AI-1-407	1 & 1.5 GAL, 3000 & 6000 PSI
AI-S-407	2.5-15 GAL, 3000 & 6000 PSI
AI-S10-407	2.5-15 GAL, 10000 PSI

*Anti-Extrusion Rings are not included in bladder kits

GAS VALVES & MOLDED BLADDER VALVE STEMS

BLADDER ACCUMULATORS - PARTS

GAS VALVES

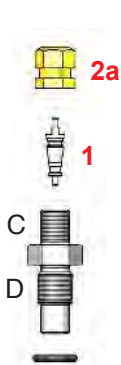

AI-GT3-309-KIT
3000 PSI

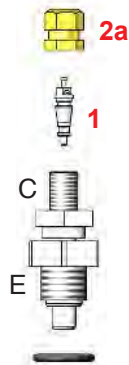

AI-S3-309-KIT
3000 PSI

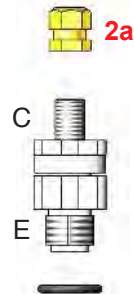

AI-S6-309-KIT
5000 & 6000 PSI

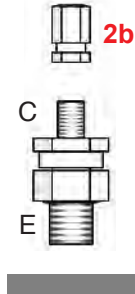

AI-S10-309-KIT
10000 PSI

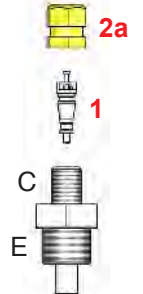

AI-S3-309-15
1500 PSI

MOLDED BLADDER VALVE STEMS

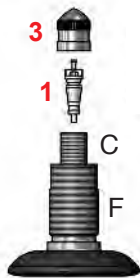

1 PT & 1 QT
3000 PSI

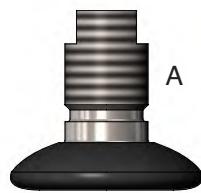

1 & 1.5 GAL
3000 PSI

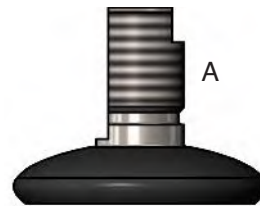

2.5-15 GAL
3000 PSI

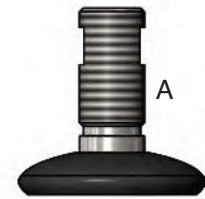

TB 1QT - 15 GAL
3000 & 6000 PSI



1 QUART
5000 PSI



1-15 GAL
6000 PSI



2.5-15 GAL GT
5000 PSI

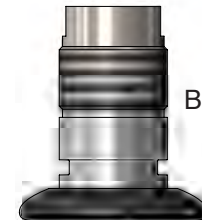

2.5-15 GAL
10000 PSI

Other custom designs available, including European designs. Drawings are not shown to scale.

COMPONENT PARTS		
PART	DESCRIPTION	AI PART #
1	Valve core	AI-S-304
2a	Valve cap	AI-S-303
2b	Valve cap, stainless	AI-S-303-SS-316
3	Valve cap, 1 quart	AI-1QT-303

OD THREAD SPECIFICATIONS	
PART	DESCRIPTION
A	7/8"-14 UNF OD
B	2"-12 UNF OD
C	.305"-32 UNEF OD
D	3/8"-24 UNF OD
E	1/2"-20 UNF OD
F	5/8"-18 UNF OD

FLUID PORTS

BLADDER ACCUMULATORS - PARTS



3000 PSI ASSEMBLIES

PART	DESCRIPTION	1 QUART	1-1.5 GALLON	2.5-15 GALLON
	Fluid port assembly (1-12)	AI-1QT-400	AI-1-400	AI-S3-400
	Plug and poppet assembly (1-6)	AI-1QT-401	AI-1-401	AI-S3-401
1	Poppet	AI-1QT-404	AI-1-404	AI-S-404
2	Spring	AI-1QT-409-SS	AI-1-409-SS	AI-S-409-SS
3	Fluid port	AI-1QT-402	AI-1-402	AI-S3-402
4	Bleed plug	-	-	-
	NPT	-	AI-S-418	AI-S-418
	SAE	-	AI-S-419	AI-S-419
5	Piston	AI-1QT-405-SS	AI-1-405-SS	AI-S-405-SS
6	Stop nut	AI-1QT-408	AI-1-408	AI-S-408-SS
7	Anti-extrusion ring	AI-1QT-407	AI-1-407	AI-S-407
8	Metal backup ring	AI-1QT-412	AI-1-412	AI-S-412
9	O-ring	AI-1QT-410	AI-1-410	AI-S-410
10	Rubber backup ring	-	AI-1-411	AI-S-411
11	Spacer	AI-1QT-406	AI-1-406	AI-S3-406
12	Locknut	AI-1QT-403	AI-1-403	AI-S-403

5000 AND 6000 PSI ASSEMBLIES

PART	DESCRIPTION	1 QUART 5000 PSI	1 GALLON 6000 PSI	2.5-15 GALLON 6000 PSI
	Fluid port assembly (1-12)	AI-1QT-400	AI-1-6-400	AI-S6-400
	Plug and poppet assembly (1-6)	AI-1QT-401	AI-1-6-401	AI-S6-401
1	Poppet	AI-1QT-404	AI-1-404	AI-S-404
2	Spring	AI-1QT-409-SS	AI-1-409-SS	AI-S6-409-SS
3	Fluid port	AI-1QT-402	AI-1-6-402	AI-S6-402
5	Piston	AI-1QT-405-SS	AI-1-405-SS	AI-S-405-SS
6	Stop nut	AI-1QT-408	AI-1-408	AI-S-408-SS
7	Anti-extrusion ring	AI-1QT-407	AI-1-407	AI-S-407
8	Metal backup ring	AI-1QT-412	AI-1-412	AI-S-412
9	O-ring	AI-1QT-410	AI-1-410	AI-S-410
10	Rubber backup ring	-	AI-1-411	AI-S-411
11	Spacer	AI-1QT-406	AI-1-6-406	AI-S6-406
12	Locknut	AI-1QT-403	AI-1-403	AI-S-403

Our fluid ports are available in carbon steel, nickel-plated carbon steel and stainless steel. Replacement fluid port assemblies for 1 Pint 3000 PSI and 2.5-15 Gallon 10000 PSI accumulators are also available.

COLLARS

BLADDER ACCUMULATORS - MOUNTING

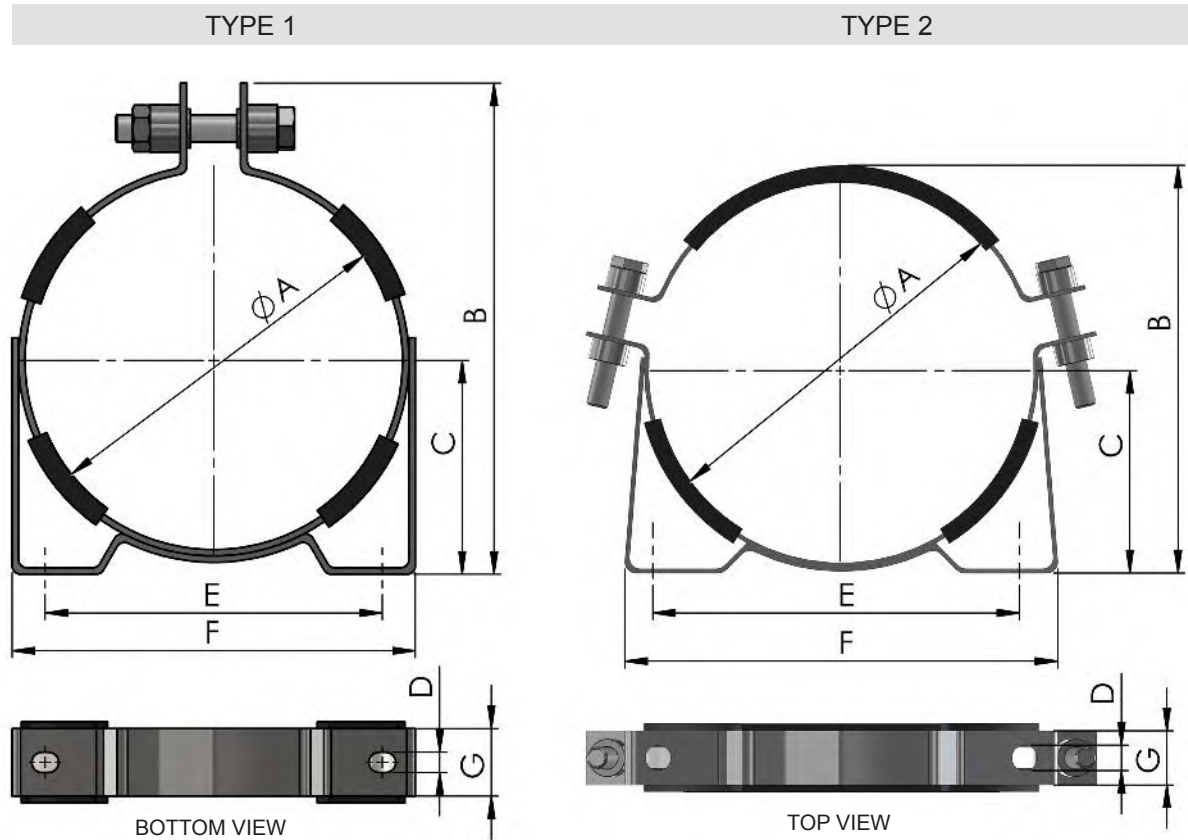

MOUNTING COLLARS FOR BLADDER ACCUMULATORS

ITEM	TYPE	PART NUMBER ZINC PLATED	PART NUMBER STAINLESS	DIMENSIONS (IN.)						
				A	B	C	D	E	F	G
1 QT 3000 & 5000 PSI Collar	1	AI-1QT-511	Contact Us	4.5	6.7	2.9	0.4	3.9	5.3	1.3
1 GAL 3000 PSI Collar	1	AI-1-511	AI-1-511-SS	6.8	9.0	3.9	0.4	6.0	7.5	1.3
1 GAL 6000 PSI Collar	1	AI-1-6-511	AI-1-6-511-SS	7.2	9.3	4.0	0.4	6.3	7.9	1.3
2.5-15 GAL 3000 PSI Collar	2	AI-S-511	AI-S-511-SS	8.9	9.4	4.7	0.6	8.5	10.0	1.3
2.5-15 GAL 6000 PSI Collar	2	AI-S6-511	AI-S6-511-SS	9.5	10.3	5.3	0.6	8.5	10.4	1.5
2.5-15 GAL 10000 PSI Collar	2	-	AI-S10-511-SS	11.6	12.5	6.4	0.7	10.7	14.8	1.5

In addition to the standard options shown above, mounting collars are available in increments of 1/4" from 3" to 20" OD (AI-CLR-300 through AI-CLR-2000). Please visit our website for more information.

Mounting collars are sold in kit form, including the appropriate adjustment bolts and rubber cushions. Mounting bolts are not included (for hole marked D). Standard collars are carbon steel plated with zinc. Stainless collars are 300 series stainless. Mounting bases are recommended and are sold separately.

These collars are mounting fasteners only and are not intended to support the entire weight of an accumulator. Contact us for specifications.

BASES

BLADDER ACCUMULATORS - MOUNTING

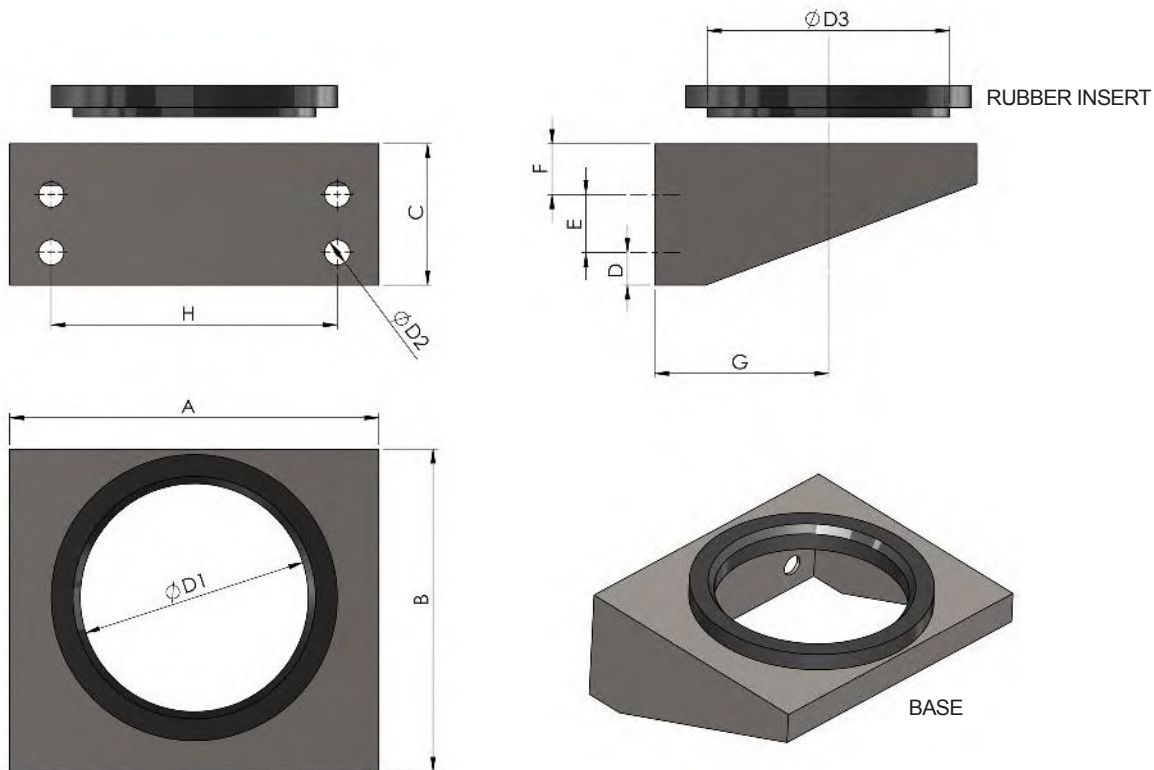

MOUNTING BASES FOR BLADDER ACCUMULATORS

ITEM	KIT PART NUMBER	DIMENSIONS (IN.)										
		A	B	C	D	D1	D2	D3	E	F	G	H
1 QT 3000 & 5000 PSI Base	AI-1QT-512	7.9	6.9	3.5	0.7	4.3	0.4	4.7	1.6	1.2	3.7	5.5
1 QT 3000 & 6000 PSI SS Base	AI-1QT-512-SS	7.9	6.9	3.5	0.7	4.3	0.4	4.7	1.6	1.2	3.7	5.5
1 GAL 3000 & 6000 PSI Base	AI-1-512	10.2	8.9	3.9	1.0	4.3	0.7	4.7	1.6	1.4	3.6	7.9
1 GAL 3000 & 6000 PSI SS Base	AI-1-512-SS	10.2	8.9	3.9	1.0	4.3	0.7	4.7	1.6	1.4	3.6	7.9
1 QT & 1 GAL Rubber Insert Replacement	AI-1QT-513	-	-	-	-	4.3	-	4.7	-	-	-	-
2.5-15 GAL 3000 PSI Base	AI-S-512	10.2	8.9	3.9	1.0	6.3	0.7	6.7	1.6	1.4	4.8	7.9
2.5-15 GAL 3000 PSI SS Base	AI-S-512-SS	10.2	8.9	3.9	1.0	6.3	0.7	6.7	1.6	1.4	4.8	7.9
2.5-15 GAL 6000 PSI Base	AI-S6-512	10.2	9.4	3.9	1.0	6.3	0.7	6.7	1.6	1.4	5.3	7.9
2.5-15 GAL 6000 PSI SS Base	AI-S6-512-SS	10.2	9.4	3.9	1.0	6.3	0.7	6.7	1.6	1.4	5.3	7.9
2.5-15 GAL 10000 PSI SS Base	AI-S10-512-SS	12	12.5	3.9	0.9	6.3	0.7	6.7	1.6	1.4	6.4	7.9
2.5-15 GAL Rubber Insert Replacement	AI-S-513	-	-	-	-	6.3	-	6.7	-	-	-	-

Bases can be used in conjunction with our rubber-lined mounting collars to achieve proper vertical alignment.

All mounting bases are sold in kit form and include the rubber insert. Mounting bolts are not included.

Standard mounting bases are zinc plated carbon steel. Stainless steel units are 300 series stainless. Dimensions are nominal and may vary within manufacturing tolerances. Mounting collars sold separately.

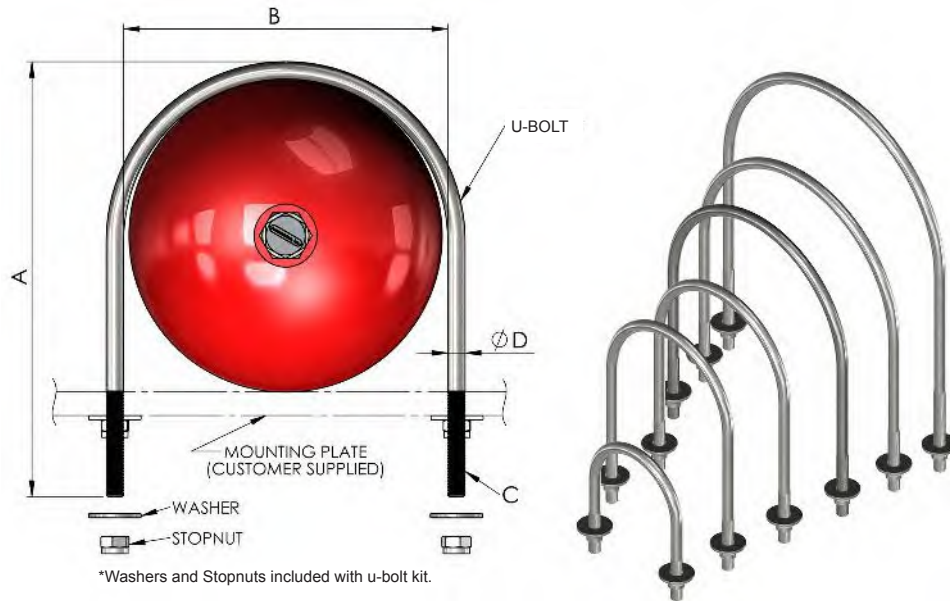

BLADDER ACCUMULATORS U-BOLTS							
SIZE	KIT QTY	PART NUMBER		DIMENSIONS (IN.)			
		CARBON STEEL	STAINLESS	A	B	C	D
1 QT 3000 & 5000	1	AI-1QT-507-KIT	AI-1QT-507-KIT-SS	6.1	4.8	2" X 3/8" -16 UN	0.3
1 QT Washer	2	AI-1QT-509	AI-1QT-509-SS	-	-	-	-
1 QT Stop Nut	2	AI-1QT-508	AI-1QT-508-SS	-	-	3/8" -16 UN	-
1 GAL 3000 PSI	1	AI-1-507-KIT	AI-1-507-KIT-SS	10.1	6.8	3" X 1/2" -13 UN	0.5
2.5 GAL 3000 PSI	1	AI-2.5-507-KIT	AI-2.5-507-KIT-SS	12.3	9.4	3.5" X 1/2" -13 UN	0.5
5-15 GAL 3000 PSI	2	AI-507-KIT	AI-507-KIT-SS	12.3	9.4	3.5" X 1/2" -13 UN	0.5
1 GAL 6000 PSI	1	AI-1-6-507-KIT	AI-1-6-507-KIT-SS	10.6	7.3	3" X 1/2" -13 UN	0.5
2.5 GAL 6000 PSI	1	AI-2.5-6-507-KIT	AI-2.5-6-507-KIT-SS	13	10	3.5" X 1/2" -13 UN	0.5
5-15 GAL 6000 PSI	2	AI-S6-507-KIT	AI-S6-507-KIT-SS	13	10	3.5" X 1/2" -13 UN	0.5
2.5-15 GAL 10000 PSI	1	-	AI-S10-507-KIT-SS	15.9	12.3	4" X 5/8" -11 UN	0.6
1-15 GAL Washer	2 or 4	AI-509	AI-509-SS	-	-	-	-
1-15 GAL Stop Nut	2 or 4	AI-508	AI-508-SS	-	-	1/2" -13 UN	-

Additional options available: Teflon Coated (-T), Rubber Coated (-RUB).
 Custom sizes available. Please contact us for more details.

All mounting U-bolts are sold in kit form with elastic stop nuts and washers. All standard units are zinc-plated carbon steel. Rubber coated units are carbon or stainless steel, shrunk-fit with buna-nitrile rubber. DuPont™ Teflon® coated units are carbon steel with Teflon spray coating.

Dimensions are nominal and may vary within manufacturing tolerances. It is recommended that you have the U-bolt on-hand when drilling mounting plate. U-bolts are not designed to work in conjunction with our mounting bases.

These u-bolts are mounting fasteners only and are not intended to support the entire weight of an accumulator. Contact us for specifications.

3000 PSI C&G ASSEMBLY

BLADDER ACCUMULATORS - CHARGING & GAUGING

CHARGING AND GAUGING KITS FOR 3000 PSI ACCUMULATORS

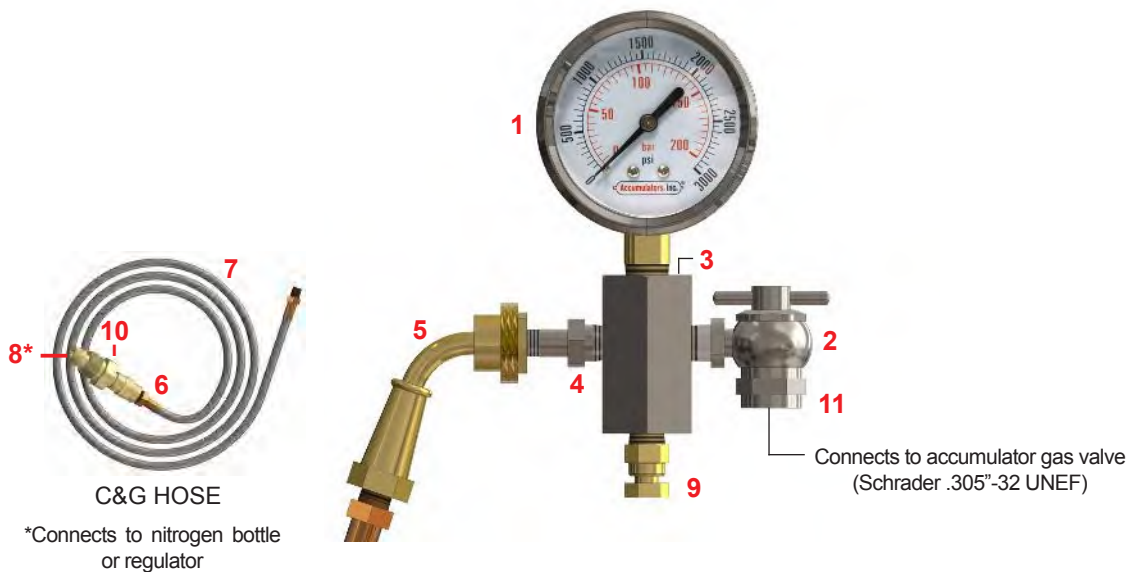

C&G HOSE

*Connects to nitrogen bottle or regulator

Connects to accumulator gas valve (Schrader .305\"-32 UNEF)

3000 PSI CHARGING KITS

Kit with 3000 PSI Gauge (Items 1a-11)	AI-CG3-3KT-SS
Kit with 6000 PSI Gauge (Items 1b-11)	AI-CG3-6KT-SS

WARNING!

AI-CG3-3KT-SS and AI-CG3-6KT-SS are rated to 3000 PSI maximum working pressure. Connects to a maximum 3000 PSI nitrogen tank with a CGA 580 connection. Do not use on accumulators with a pressure higher than 3000 PSI. It is highly recommended that a N₂ gas regulator be used while charging any accumulator. Use dry nitrogen gas (N₂) only.

ALSO AVAILABLE:

- Complete accumulator repair kits
- N₂ gas regulators
- Special order C&G kits with different connections and different hose lengths

COMPONENT PARTS LIST

PART	DESCRIPTION	PART NUMBER
1a	3000 PSI Gauge	AI-CG3-001
1b	6000 PSI Gauge	AI-CG6-001
2	Air Chuck	AI-CG-002
3	Adapter Block	AI-CG-003
4	Tank Valve	AI-CG-005-KIT
5	Swivel Connector	AI-CG-004
6	Coupler	AI-CG-006
7	Hose (8 ft.)	AI-CG-007-SS
8	Gland (Nipple)	AI-CG-008
9	Bleed Valve	AI-CG-009
10	Nut	AI-CG-011
11	Copper Washer	AI-CG-020
	TR Adapter (Connects to 11)	AI-TR-015
	Gauging & Head Assembly, 3000 PSI gauge (Items 1a-4,9,11)	AI-CG3-313
	Gauging & Head Assembly, 6000 PSI gauge (Items 1a-4,9,11)	AI-CG6-613
	Hose Assembly(items 5-8,10)	AI-CG-017-SS
	Valve Core (internal)	AI-S-304

6000 PSI C&G ASSEMBLY

BLADDER ACCUMULATORS - CHARGING & GAUGING

CHARGING AND GAUGING KITS FOR 4000, 5000 & 6000 PSI ACCUMULATORS

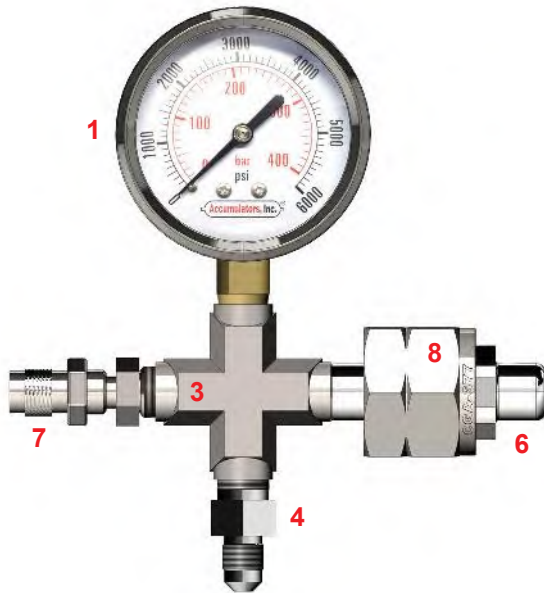

C&G HOSE

*Connects to accumulator high pressure gas valve

FULL ASSEMBLY COMPONENT PARTS LIST

PART	DESCRIPTION	PART NUMBER
	Complete Kit (Items 1-8)	AI-CG6-6KT-SS
1	Gauge, 6000 PSI	AI-CG6-501-SS
2	Air Chuck	AI-CG6-502-SS
3	Cross	AI-CG6-503-SS
4	JIC Adapter	AI-CG6-506-SS
5	Hose (8 ft.)	AI-CG6-507-SS
6	Cylinder Valve Tube	AI-CG6-508-SS
7	Bleed Valve	AI-CG6-509-SS
8	Cylinder Valve Nut	AI-CG6-511-SS
	Hose Assembly(Items 2,4,5)	AI-CG6-517-SS
	Gauging & Head Assembly (Items 1, 3, 4, 6, 7, 8)	AI-CG6-613-SS

WARNING!

AI-CG6-6KT-SS is rated to 6000 PSI maximum working pressure. Do not use on accumulators with a pressure higher than 6000 PSI. Connects to a maximum 6000 PSI nitrogen tank with a CGA 677 connection. It is highly recommended that a N₂ gas regulator be used while charging any accumulator. Use dry nitrogen gas (N₂) only.

ALSO AVAILABLE:

- Complete accumulator repair kits
- N₂ gas regulators
- Special order C&G kits with different connections and different hose lengths

10000 PSI C&G ASSEMBLY

BLADDER ACCUMULATORS - CHARGING & GAUGING

10000 PSI CHARGING AND GAUGING ASSEMBLY

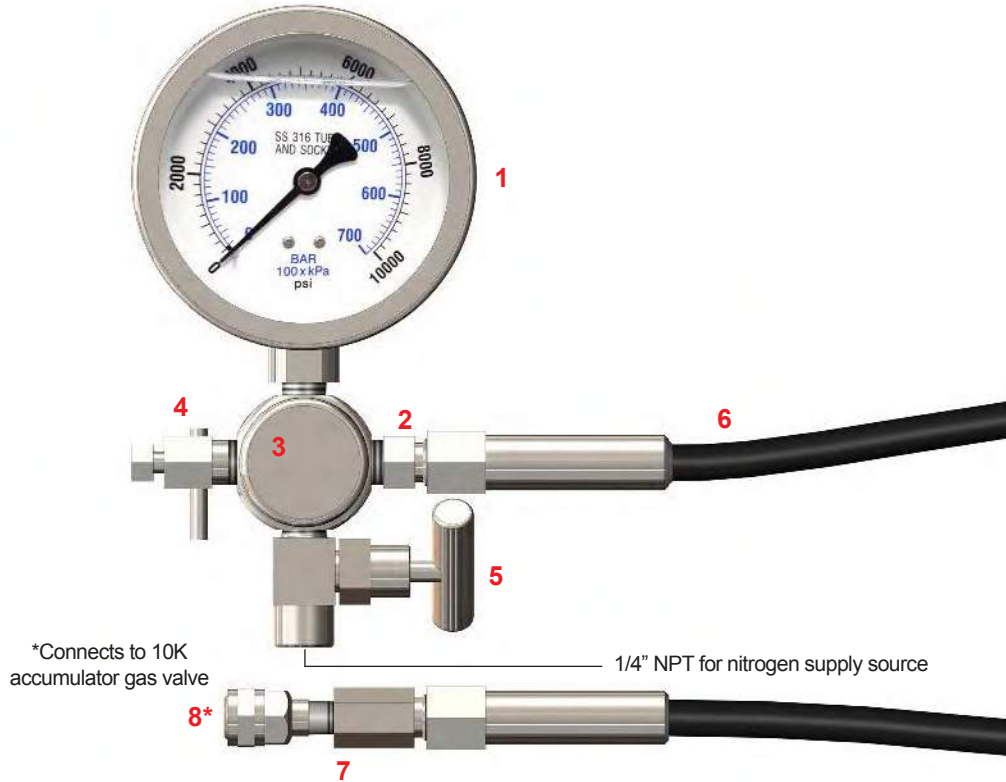

WARNING!

AI-CG10-10KT-SS is rated to 10000 PSI maximum working pressure. Do not use on accumulators with a pressure higher than 10000 PSI. It is highly recommended that a N₂ gas regulator be used while charging any accumulator. Use dry nitrogen gas (N₂) only.

ALSO AVAILABLE:

- Complete accumulator repair kits
- N₂ gas regulators
- Special order C&G kits with different connections and different hose lengths

COMPONENTS LIST

PART	DESCRIPTION	PART NUMBER
	10K C&G Assembly (Items 1-8)	AI-CG10-10KT-SS
1	Gauge (0-10000 PSI, liquid filled)	AI-CG10-001-L-SS
2	Block Fitting	AI-ADP-A-NPT4M-MH6M-15-SS
3	Adapter Block	AI-CG10-503-SS
4	Bleed Valve	AI-CG10-509-SS
5	Needle Valve	AI-CG10-510-SS
6	Hose (4ft)	AI-CG10-507-4-R
7	Air Chuck Adapter	AI-ADP-A-NPT2F-MH6M-15-SS
8	Air Chuck	AI-CG10-502-SS

PERMANENT MOUNT PRESSURE MONITORS

BLADDER ACCUMULATORS - CHARGING & GAUGING

3000 AND 6000 PSI DELUXE PERMANENT MOUNT PRESSURE MONITORS

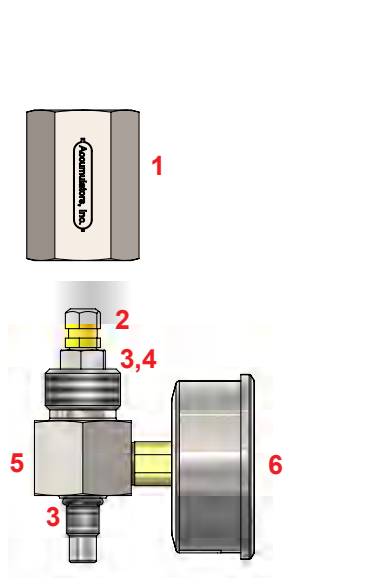

3000 PSI

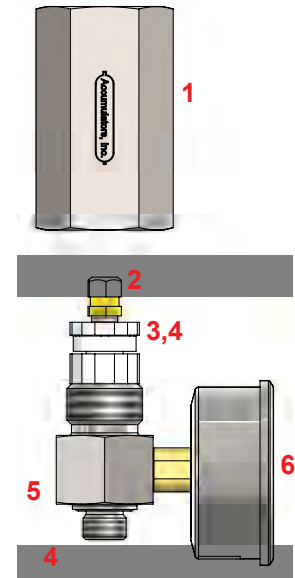

6000 PSI

AI-PM3-3KT-L-SS COMPONENTS LIST 1 – 40 GAL

PART	DESCRIPTION	PART NUMBER
1	Protective Cap	AI-306-4-SS
2	Valve Cap	AI-S-303
3	Gas Valve	AI-GT3-309-SS
4	O-Ring	AI-GT3-311
5	Pressure Monitor Block, Deluxe, 3000 PSI	AI-PM3-003-D-SS
6	Gauge, 3000 PSI, Liquid Filled	AI-CG3-001-1-L-SS

AI-PM6-6KT-L-SS COMPONENTS LIST 1 QT – 15 GAL

PART	DESCRIPTION	PART NUMBER
1	Protective Cap	AI-306-2-SS
2	Valve Cap	AI-S-303
3	High Pressure Gas Valve	AI-S6-309
4	O-Ring	AI-S6-310
5	Pressure Monitor Block, Deluxe, 6000 PSI	AI-PM6-003-D-SS
6	Gauge, 6000 PSI, Liquid Filled	AI-CG6-001-1-L-SS

3000 AND 6000 PSI BASIC PERMANENT MOUNT PRESSURE MONITORS

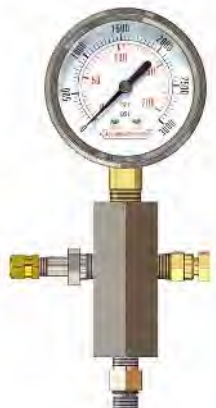

3000 PSI



6000 PSI

- These units are intended to be mounted permanently on the valve stem of the accumulator to monitor hydraulic system pressure. Nitrogen precharge may only be measured when hydraulic line pressure is zero PSI.
- We recommend the use of a liquid-filled gauge for high-cycle shock applications.
- Accumulator gas valve must be removed prior to installation. Ensure all accumulator pressure has been removed before beginning installation.
- Extended versions available for Top Repairable bladder accumulators and piston accumulators.
- Custom and digital assemblies are available.

MAINTENANCE KITS

BLADDER ACCUMULATORS - ACCESSORIES

Everything you need to precharge, maintain and repair any accumulator up to 6000 PSI. Includes spare parts. Additional maintenance kits for 10000 PSI accumulators and other special applications are also available.”



AI-TKIT COMPLETE 3000 PSI MAINTENANCE KIT		
PART #	DESCRIPTION	QUANTITY
AI-TR-015	Gas Valve Extension	1
AI-501	Bladder Pull Rod	4
AI-505	Spanner Wrench	1
AI-506	Valve Core Tool	1
AI-527	Valve Core Torque Wrench	1
AI-516	Aluminum Tool Case	1
AI-CG-002	Air Chuck	1
AI-GT3-309-KIT	Gas Valve	1
AI-S-304	Valve Core	5
AI-CG3-000-SS	C&G Assembly 3000 PSI	1



AI-TKIT-6 COMPLETE 6000 PSI MAINTENANCE KIT		
PART #	DESCRIPTION	QUANTITY
AI-501	Bladder Pull Rod	4
AI-505	Spanner Wrench	1
AI-516	Aluminum Tool Case	1
AI-S6-309-KIT	High Pressure Gas Valve 6000 PSI	1
AI-CG6-550-SS	C&G Assembly 6000 PSI	1



AI-TKIT-1 DELUXE MAINTENANCE KIT 3000 PSI & 6000 PSI		
PART #	DESCRIPTION	QUANTITY
AI-TR-015	Gas Valve Extension	1
AI-501	Bladder Pull Rod	4
AI-505	Spanner Wrench	2
AI-506	Valve Core Tool	1
AI-527	Valve Core Torque Wrench	1
AI-516	Aluminum Tool Case	1
AI-CG-002	Air Chuck	1
AI-GT3-309-KIT	Gas Valve	2
AI-S-304	Valve Core	5
AI-GT3-311	Gas Valve O-ring	5
AI-CG3-000-SS	C&G Assembly 3000 PSI	1
AI-S6-309-KIT	High Pressure Gas Valve 6000 PSI	1
AI-CG6-550-SS	C&G Assembly 6000 PSI	1
AI-511	Accumulator Lifting Hook Assembly	1
AI-515	Gas Valve Tool TR	2



AI-TKIT-B BASIC 3000 PSI MAINTENANCE KIT		
PART #	DESCRIPTION	QUANTITY
AI-TR-015	Gas Valve Extension	1
AI-501	Bladder Pull Rod	4
AI-505	Spanner Wrench	1
AI-506	Valve Core Tool	1
AI-527	Valve Core Torque Wrench	1
AI-519	19" Tool Case	1
AI-CG3-000-SS	C&G Assembly 3000 PSI	1

BLADDER ACCUMULATORS - ACCESSORIES

AI-501 PULL ROD



Used to help pull the bladder through the accumulator shell during assembly and bladder replacement. For 1 quart, 1 gallon or 2.5 gallon accumulators.

(AI-502): For 5-gallon accumulators

(AI-503): For 10-gallon or 11-gallon accumulators

(AI-504): For 15-gallon accumulators

AI-TR-501-SS PULL ROD



Used for top repairable bladder accumulators. The “T” section of the pull rod is designed so that the rod cannot fall into the accumulator and also provides additional leverage for the technician to properly remove the bladder.

AI-506 VALVE CORE TOOL



Our valve core tool allows the user to remove or reinstall the valve core in our standard 3000 psi gas valve, as well as depress the valve core for gas removal. Also includes ID and OD thread chasing capabilities.

AI-511 LIFTING HOOK ASSEMBLY



Our lifting hook assembly allows the user to connect a chain or other lifting apparatus to the gas end of our accumulators. We recommend this tool to lift all accumulator sizes over 2.5 gallons. Load-tested assemblies available with a test certificate at additional cost. Standard size is 7/8”-14; 2”-12 size available as part number AI-GT-511.

AI-505 SPANNER WRENCH



Used for removal and replacement of the locknuts at the fluid end of an accumulator and at the gas end of top repairable accumulator models.

AI-TR-015 GAS VALVE EXTENSION



Our gas valve extension allows the user to connect our charging & gauging assembly (AI-CG3-3KT-SS) to the gas valve in a 3000 psi top-repairable accumulator.

AI-527 VALVE CORE TORQUE WRENCH



Use this tool during installation of a valve core to ensure the core is installed to precisely the correct torque; over or under-tightening the valve core can cause gas leakage and accumulator failure.

AI-515-KIT TR GAS VALVE TOOL



This is a set of 2 specially-designed wrenches for the installation or removal of the gas valve in a 6000 psi top-repairable accumulator.

SAFETY BLOCKS

BLADDER ACCUMULATORS - ACCESSORIES

Our accumulator safety block is a multifunctional valve placed between the hydraulic accumulator and the operating system. The safety block allows for isolation of the accumulator for maintenance or system testing, and will function as an emergency shut-off device or pressure relief valve to protect the hydraulic system from overpressurization or system failure.

Our accumulator safety blocks incorporate the following components:

- 90-degree full-orifice ball valve to isolate the accumulator from the system
- Manual adjustable safety relief valve
- Manually-operated bleed valve; bleeds down accumulator safely
- Optional female port for pressure gauge options
- Manual release handle standard

See accumulators.com/safetyblocks.html for more information.



MODEL 1 | ASB-850

Model one is designed for use with our 1 quart and 1 gallon bladder accumulators equipped with female SAE fluid ports. Safety block outlet port is available in SAE -8, -12 and -20 sizes. This model is rated up to 2900 PSI MAWP.



MODEL 2 | ASB-800

This model is designed for our 2.5 through 15 gallon accumulators. Best suited for use with SAE split flange connections for ease of installation and maintenance. The SAE split flanges are rated for code 61 or code 62 series. This model is rated up to 5800 PSI MAWP.

- Optional solenoid-operated dump valve
- Optional lock-out plates to avoid unauthorized access to open or close valve

NITROGEN GAS BOOSTER PACKAGES

BLADDER ACCUMULATORS - ACCESSORIES



Our nitrogen gas boosters are designed to boost directly from high pressure storage cylinders to outlet pressures of up to 10000 psi. The unit ensures maximum outlet pressure fills even if the supply storage pressure drops as low as 500 psi.

The booster operates from a low-pressure, conventional compressed air source or “bootstraps,” directly from the high-pressure nitrogen supply. In the shop-air drive mode, non-contaminated outlet gas is assured through complete dual-vented separation from the drive section. The high-pressure section of the booster is cooled by the drive exhaust gas and requires no lubrication. Valves and gauges are SS line-mounted to the booster. All items are mounted on a painted, aluminum tubular frame with carry handles.

CONTROLS INCLUDED

- Single acting double drive gas booster configuration.
- Automatic control to stop/restart the booster when the outlet pressure exceeds set point; pre-selected pressure up to 6000 psi (adjustable, depending on model).
- Manual start and stop
- High pressure air controls (HP regulator, relief valve, inlet & regulated outlet gauges and on/off valve)
- Adjustable safety relief valve
- Gas inlet and outlet gauges

SPECIFICATIONS

- Dimensions: 30”L x 12”D x 12”H
- Weight: 60 pounds
- Maximum outlet pressure: 6000, 7500, or 10000 psi

BLADDER KIT STORAGE & CARE

BLADDER ACCUMULATORS

BLADDER KIT STORAGE

1. Replacement bladder kits are shipped in sealed UV protective black bags. Store bladders in these bags until needed.
2. The cartons in which bladders are shipped are designed to prolong storage life. Keep bladders in these boxes until needed for service.
3. Keep the tops of the cartons sealed at all times. After removing some of the bladders, reseal the carton. By keeping the carton and bag closed, degradation from sunlight and artificial lighting may be minimized.
4. Immediately upon receipt, place bladders in a storage area. Keep this area free from all sunlight, ultraviolet light, fluorescent lights, electrical motors, electronic equipment and other ozone producing items. At no time should the bladders be exposed to temperatures that exceed 80 F.
5. Following the above conditions bladders may be stored for up to 6 months.

For longer-term storage, the following additional optimum conditions should be included:

1. The storage area should be isolated in a closed clean room, maintained at 60 F to 72 F at all times.
2. Bladders should be slightly inflated with dry nitrogen gas (N₂) to 70% of their design diameter. Place in UV protective bags and hang vertically from the gas stem. If placed horizontally, they should be rotated monthly.
3. Storage area must be dark with no sunlight, ultraviolet light, fluorescent light or any heat source. Room should be dry to prevent gas stem corrosion. No electrical motors, electronic equipment or other ozone producing items should be within 10 meters of the room.
4. Under these conditions bladders can be stored for extended periods.

BLADDER FAILURE MOST COMMON CAUSES

1. STAR BURST (AT BOTTOM OF BLADDER)

- **CAUSE:** Excessively rapid precharging causes bladder to freeze and burst or extrude through plug orifice before poppet can close. **SOLUTION:** Always use an approved nitrogen gas regulator for precharging.
- **CAUSE:** Low fluid temperature causes a bladder to become brittle. **SOLUTION:** Use a low temperature bladder.
- **CAUSE:** Lack of bladder lubrication causes excessive stretching. **SOLUTION:** Always lubricate bladder prior to use, using fluids with good lubricity. Use a water service accumulator for water-based or low lubricity fluids.

2. STAR BURST (6" TO 8" FROM BOTTOM OF BLADDER)

- **CAUSE:** Folding of bladder bottom during replacement causes it to be pinned against shell wall. Bladder cannot stretch to close the poppet and it bursts. **SOLUTION:** Never fold/twist bladder when repairing unit.

3. POPPET CUT (AT BOTTOM OF BLADDER)

- **CAUSE:** Excessive flow rate causes bladder to extrude down through plug before poppet can close. **SOLUTION:** Use a High Flow accumulator or multiple standard accumulators.
- **CAUSE:** Poppet does not close all the way, which causes the bladder to extrude. **SOLUTION:** Inspect plug and poppet assembly for damage, corrosion or debris. Replace as needed.
- **CAUSE:** Bottom of bladder has hardened due to the reduction of plasticizers from the elastomer, which is caused by excessive heat or chemical degradation. **SOLUTION:** Check elastomer fluid capability.

4. PICK-OUT (PIN HOLE NEAR TOP OF BLADDER)

- **CAUSE:** Operation of the accumulator with insufficient precharge allows fluid pressure to force bladder to extrude into gas valve. **SOLUTION:** Always operate accumulator with proper nitrogen gas precharge. Check precharge often.

5. BUBBLES, BLISTERS OR RUBBER FLAKING ON BLADDER SURFACE OR BURNT SMELL

- **CAUSE:** Incompatible fluid or excessive temperature. **SOLUTION:** Refer to rubber compatibility chart and temperature chart for correct elastomer compounds.

6. TEARING OF BLADDER AROUND GAS VALVE STEM

- **CAUSE:** Twisting of gas valve stem during replacement. **SOLUTION:** When tightening gas valve hex jam nut, use a second wrench to keep gas valve from twisting. Do not use excessive torque.

7. GROOVES OR HOLES ON BLADDER SURFACE

- **CAUSE:** Fluid contamination causes foreign debris entrapment between bladder and shell during cycling. **SOLUTION:** Use clean fluid and proper filtration.

8. RUBBER HAS BECOME BRITTLE CAUSING CRACKS OR FLAKES

- **CAUSE:** Excessive heat can cause the bladder to re-cure or harden due to the reduction of plasticizers from the elastomer. **SOLUTION:** Check elastomer fluid compatibility and/or install heat exchanger in system. Do not use or store units in hot environment or in direct sunlight.

SPECIAL ORDER BLADDER ACCUMULATORS

BLADDER ACCUMULATORS

Accumulators, Inc. offers many special products and services including Buoyant Float Accumulators (p. 43), interior and exterior coatings, alternate design approvals and user-specified custom items.

SPECIAL SERVICES

We offer a variety of special services on all of our accumulators. We offer five main service types (below), but can customize to meet your needs. To order, add the 2-letter code in parenthesis to the end of our standard part number.

(WS) WATER SERVICE ACCUMULATORS

For high water content applications and when internal corrosion protection is necessary, these units have Phenolic coated interiors and two-coat, zinc-epoxy painted exteriors. The units contain a mix of electroless-nickel plated and stainless steel components, designed for in-plant use.

(PS) WATER & CHEMICAL SERVICE ACCUMULATORS

Our PS units have phenolic-coated interiors for corrosion protection and primed exteriors with stainless steel components. Used primarily for high water content applications when stainless steel parts are necessary.

(NP) NICKEL PLATED ACCUMULATORS

Both the interior and exterior of these units are electroless-nickel plated, perfect for chemical and harsh environment applications. Stainless steel components.

(XS) EXTREME SERVICE ACCUMULATORS

These accumulators were created specifically for offshore drilling applications. These units have been designed with maximum corrosion protection, high-pressure fittings, low-temperature components and improved external sealing. Thousands of these units are currently being operated subsea at various depths.

(AS) ALL STAINLESS STEEL ACCUMULATORS

These accumulators have a seamless (non-welded) forged 316 stainless steel shell. All components are 300 series stainless steel, available in standard 2000 psi and special order higher-rated designs.

STANDARD CORROSION PROTECTION OPTIONS			
PART	WATER SERVICE (WS)	NICKEL PLATED (NP)	EXTREME SERVICE (XS)
Protective Cap	Carbon Steel	316 Stainless	316 Stainless
Hex Jam Nut	Zinc Plated Carbon	300 Series Stainless	300 Series Stainless
Oil Port	Nickel Plated Carbon	316 Stainless	316 Stainless
Poppet	300 Series Stainless	300 Series Stainless	300 Series Stainless
Spring	300 Series Stainless	300 Series Stainless	300 Series Stainless
Piston	300 Series Stainless	300 Series Stainless	300 Series Stainless
Elastic Stop Nut	300 Series Stainless	300 Series Stainless	300 Series Stainless
Anti-Extrusion Ring	Nickel Plated Carbon	Nickel Plated Carbon	Nickel Plated Carbon
Spacer	Nickel Plated Carbon	316 Stainless	316 Stainless
Locknut	Nickel Plated Carbon	316 Stainless	316 Stainless
Interior Shell	Phenolic Coating	Electroless Nickel	Phenolic Coating
Exterior Shell	3-Coat Marine Epoxy	Electroless Nickel	3-Coat Marine Epoxy
Bleed Plug	316 Stainless	316 Stainless	316 Stainless
Gas Valve Stem	Carbon Steel	316 Stainless	316 Stainless
Metal Backup Ring	316 Stainless	316 Stainless	316 Stainless

SPECIAL ORDER ACCUMULATOR OPTIONS						
TYPE	WS	PS	NP	XS	AS	CS
Phenolic Interior	X	X		X		
Stainless Parts		X	X	X	X	X
Stainless A/X Ring					X	
Nickel Plated Shell			X			
Primed Exterior only		X				X
Nickel Plated Parts	X					
Nickel Plated A/X Ring	X	X	X	X		X
Marine Epoxy Exterior	X			X		
Stainless Shell					X	

Other special order materials and combinations are available as required to meet your needs.

ALTERNATE DESIGN APPROVALS

Most ACC INC accumulators are designed to the strict guidelines of the ASME Boiler and Pressure Vessel Code, witnessed and stamped with the ASME symbol, and registered with the National Board of Boiler and Pressure Vessel Inspectors. Many other design approvals or authority reviews, such as CE, DNV, ABS, CRN, Lloyds, NR-13, AS1210, etc. are available by request at additional cost. We can also modify existing units under the National Board Inspection Code "R" stamp.

On-site



Accumulator Repair for bladder, piston and diaphragm accumulators.

Save Time, Save Money, In 4 Steps.



1 | Accumulator



2 | Call Accumulators,



4 | Accumulator



3 | Accumulators, Inc.



Call 713-465-0202 to speak with one of our accumulator specialists to schedule an appointment.



PISTON ACCUMULATORS



Visit accumulators.com for more information.

OVERVIEW

PISTON ACCUMULATORS



A piston accumulator consists of a sealed cylindrical body with a polished and honed ID surface and with fluid or gas porting at each end. A lightweight floating piston separates the gas side of the accumulator from the fluid side or provides a transfer barrier between two fluids. The piston accumulator is charged with dry nitrogen gas to a set precharge pressure determined by the application requirements. As system pressure increases, the piston moves up the cylinder tube compressing the nitrogen, or in the opposite direction as system pressure returns to normal and thus discharging fluid from the accumulator.

Accumulators, Inc. offers many different sizes and pressure ratings in both carbon steel and stainless steel, and with an array of internal and external coatings. Piston seals are compatible with a variety of system fluids and temperature ranges.

PARTS, ACCESSORIES & TOOLS

Gas Valves	11
C & G Assemblies	16
Tools	20
Safety Blocks	22
Nitrogen Regulators	23
Mounting	32

MAINTENANCE & SELECTION

Ordering Table	29
FAQs & Maintenance	47

ENGINEERING, SERVICE & TRAINING

Custom Engineering	44
Hazmat & Dot Exemption	45
Training Services	46

PISTON ACCUMULATOR ORDERING TABLE

PISTON ACCUMULATORS

Use the table below to determine the part number for your desired piston accumulator. For help sizing your accumulator, selecting a compatible elastomer, and to obtain a quote on accumulators and all our other products, visit our website at accumulators.com.

Select the desired option from each list and place the corresponding code in its proper place:

APPROVAL CODE	NOMINAL SIZE	PRESSURE	CYLINDER BORE	TOP END PORT(S)	BOTTOM END PORT(S)	SEALS	MATERIAL	EXAMPLE
PA	15	3100	6B	0G	2F	V	SS	= PA1531006B0G2FVSS

APPROVAL CODE ¹		PRESSURE ³		TOP AND BOTTOM PORTS ^{4,5}		SEALS ⁴	
OPTION	CODE	OPTION	CODE	OPTION	CODE	OPTION	CODE
ACC INC	PA	3000 PSI	3100	3/8"-24 SAE w/gas valve	0	Buna-Nitrile	Blank
ASME	PX	4000 PSI	4100	3/4"-12 SAE (#8)	1	Butyl	B
DNV	PN	6000 PSI	6100	1-1/16"-12 SAE (#12)	2	EPDM	E
ABS	PB	7500 PSI	7.5100	1-5/16"-12 SAE (#16)	3	Fluorocarbon	V
CE	PP	10000 PSI	10100	1-7/8"-12 SAE (#24)	4	Low-Temp Buna	L
CRN	PR	15000 PSI	15100	Code 61, 2" SAE	5	Polypropylene	P
ABS, DNV	PD	CYLINDER BORE⁴		Code 62, 1.5" SAE	6	Teflon	T
SIZE²		OPTION	CODE	3/8" MP	7	KEL-F	KELF
OPTION	CODE	2" Bore	2B	2.5"-12 SAE (#32)	8	MATERIALS	
1/2 Pint	.5PT	3" Bore	3B	1" NPT	9	OPTION	CODE
1 Pint	1PT	4" Bore	4B	1/2"-20 SAE w/gas valve	10	Carbon Steel	Blank
1 Quart	1QT	5" Bore	5B	3/4" NPT	11	Stainless	SS
1/2 Gallon	2QT	5.5" Bore	5.5B	1/2" NPT	12	Chrome-plated ID	CP
1 Gallon	1	6" Bore	6B	Code 61, 1.5" SAE	13		
2.5 Gallon	2.5	7" Bore	7B	Solid, no port	15		
5 Gallon	5	8" Bore	8B	9/16" MP	16		
7.5 Gallon	7.5	10" Bore	10B	1-5/8" SAE (#20)	17		
10 Gallon	10	12" Bore	12B				
15 Gallon	15						
20 Gallon	20						
40 Gallon	40						

¹ ASME standard for all accumulators larger than 6" bore.

² Larger and custom sizes available.

³ Higher and custom pressures available.

⁴ Many other options available.

⁵ Code followed by G or F to indicate a Top Port or Bottom Port.

Only the most common options are shown above. We have many more options and products available.

STANDARD PISTONS

PISTON ACCUMULATORS

With hundreds of options, it is impossible to show all the configurations available for our piston accumulators. Shown below are a sampling of our stock models. We can also design an accumulator to meet your exact requirements or to match an existing unit.

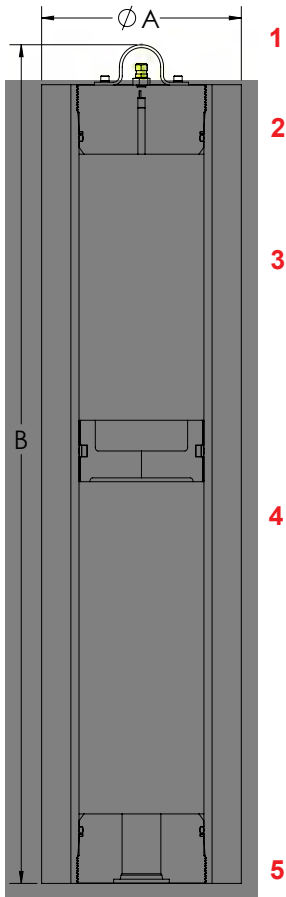

STANDARD COMPONENT PARTS

- 1 Gas Valve
- 2 Gas Cap
- 3 Shell
- 4 Piston
- 5 Fluid Cap

3 INCH BORE 3000 PSI PISTONS

MODEL NUMBER	NOMINAL SIZE	GAS CAPACITY	DRY WEIGHT	A (OD)	B (OAL)	MOUNTING CLAMP	SEAL KIT
		IN ³	LBS.	IN	IN		
PA.5PT31003B0GXF	0.5 PT	19	11	3.5	7.5	AI-CLR-350	PA-3B-4KT
PA1PT31003B0GXF	1 PT	35	12	3.5	9.75	AI-CLR-350	PA-3B-4KT
PA1QT31003B0GXF	1 QT	68	16	3.5	14.5	AI-CLR-350	PA-3B-4KT
PA2QT31003B0GXF	2 QT	124	21	3.5	22.5	AI-CLR-350	PA-3B-4KT
PA131003B0GXF	1 GAL	241	33	3.5	39	AI-CLR-350	PA-3B-4KT

4 INCH BORE 3000 PSI PISTONS

MODEL NUMBER	NOMINAL SIZE	GAS CAPACITY	DRY WEIGHT	A (OD)	B (OAL)	MOUNTING CLAMP	SEAL KIT
		IN ³	LBS.	IN	IN		
PA1QT31004B10G3FK	1 QT	64	33	4.75	13	AI-1QT-511	PA-4B-4KT-ALT
PA131004B10G3FK	1 GAL	237	53	4.75	26.75	AI-1QT-511	PA-4B-4KT-ALT
PA2.531004B10G3FK	2.5 GAL	584	93	4.75	54.5	AI-1QT-511	PA-4B-4KT-ALT

6 INCH BORE 3000 PSI PISTONS

MODEL NUMBER	NOMINAL SIZE	GAS CAPACITY	DRY WEIGHT	A (OD)	B (OAL)	MOUNTING CLAMP	SEAL KIT
		IN ³	LBS.	IN	IN		
PA131006B0GXF-R1	1 GAL	244	67	6.5	16.5	AI-CLR-650	PA-6B-4KT
PA2.531006B0GXF-R1	2.5 GAL	598	94	6.5	30	AI-CLR-650	PA-6B-4KT
PA531006B0GXF-R1	5 GAL	1168	139	6.5	52	AI-CLR-650	PA-6B-4KT
PA7.531006B0GXF-R1	7.5 GAL	1753	185	6.5	74.5	AI-CLR-650	PA-6B-4KT
PA1031006B0GXF-R1	10 GAL	2335	231	6.5	97	AI-CLR-650	PA-6B-4KT
PA12.531006B0GXF-R1	12.5 GAL	2908	276	6.5	119	AI-CLR-650	PA-6B-4KT

8 INCH BORE 3000 PSI PISTONS

MODEL NUMBER	NOMINAL SIZE	GAS CAPACITY	DRY WEIGHT	A (OD)	B (OAL)	MOUNTING CLAMP	SEAL KIT
		IN ³	LBS.	IN	IN		
PX531008B10GXF-R1	5 GAL	1207	260	9.5	33	AI-S6-511	PA-8B-4KT
PX7.531008B10GXF-R1	7.5 GAL	1785	327	9.5	44.5	AI-S6-511	PA-8B-4KT
PX1031008B10GXF-R1	10 GAL	2362	394	9.5	56	AI-S6-511	PA-8B-4KT
PX12.531008B10GXF-R1	12.5 GAL	2940	460	9.5	67.5	AI-S6-511	PA-8B-4KT
PX1531008B10GXF-R1	15 GAL	3517	527	9.5	79	AI-S6-511	PA-8B-4KT
PX2031008B10GXF-R1	20 GAL	4672	661	9.5	102	AI-S6-511	PA-8B-4KT
PX2531008B10GXF-R1	25 GAL	5832	795	9.5	125	AI-S6-511	PA-8B-4KT
PX3031008B10GXF-R1	30 GAL	6971	927	9.5	147.5	AI-S6-511	PA-8B-4KT
PX4031008B10GXF-R1	40 GAL	9281	1194	9.5	193.5	AI-S6-511	PA-8B-4KT

8 INCH BORE 4000 PSI PISTONS

MODEL NUMBER	NOMINAL SIZE	GAS CAPACITY	DRY WEIGHT	A (OD)	B (OAL)	MOUNTING CLAMP	SEAL KIT
		IN ³	LBS.	IN	IN		
PX541008B10GXF	5 GAL	1272	300	9.5	36	AI-S6-511	PA-8B-4KT
PX7.541008B10GXF	7.5 GAL	1781	356	9.5	46	AI-S6-511	PA-8B-4KT
PX1041008B10GXF	10 GAL	2312	416	9.5	56.5	AI-S6-511	PA-8B-4KT
PX12.541008B10GXF	12.5 GAL	2940	486	9.5	69	AI-S6-511	PA-8B-4KT
PX1541008B10GXF	15 GAL	3541	555	9.5	81	AI-S6-511	PA-8B-4KT

continued on next page

STANDARD PISTONS

PISTON ACCUMULATORS

8 INCH BORE 4000 PSI PISTONS (CONTINUED)

PX2041008B10GXF	20 GAL	4673	681	9.5	103.5	AI-S6-511	PA-8B-4KT
PX2541008B10GXF	25 GAL	5828	811	9.5	126.5	AI-S6-511	PA-8B-4KT
PX3041008B10GXF	30 GAL	7006	938	9.5	150	AI-S6-511	PA-8B-4KT

4 INCH BORE 6000 PSI PISTONS

MODEL NUMBER	NOMINAL SIZE	GAS CAPACITY	DRY WEIGHT	A (OD)	B (OAL)	MOUNTING CLAMP	SEAL KIT
		IN ³	LBS.	IN	IN		
PA1QT61004B10GXF	1 QT	64	33	5	11.5	AI-CLR-500	PA-4B-4KT
PA2QT61004B10GXF	2 QT	126	43	5	16.5	AI-CLR-500	PA-4B-4KT
PA161004B10GXF	1 GAL	240	61	5	25.5	AI-CLR-500	PA-4B-4KT
PA2.561004B10GXF	2.5 GAL	584	116	5	53	AI-CLR-500	PA-4B-4KT
PA461004B10GXF	4 GAL	930	171	5	80.5	AI-CLR-500	PA-4B-4KT

7 INCH BORE 6000 PSI PISTONS

MODEL NUMBER	NOMINAL SIZE	GAS CAPACITY	DRY WEIGHT	A (OD)	B (OAL)	MOUNTING CLAMP	SEAL KIT
		IN ³	LBS.	IN	IN		
PX561007B10GXF	5 GAL	1188	397	9.13	41.5	AI-S-511	PA-7B-4KT
PX1061007B10GXF	10 GAL	2343	625	9.13	71.5	AI-S-511	PA-7B-4KT
PX12.561007B10GXF	12.5 GAL	2921	739	9.13	86.5	AI-S-511	PA-7B-4KT
PX1561007B10GXF	15 GAL	3498	853	9.13	101.5	AI-S-511	PA-7B-4KT
PX2061007B10GXF	20 GAL	4648	1080	9.13	131.5	AI-S-511	PA-7B-4KT
PX2561007B10GXF	25 GAL	5820	1311	9.13	162.0	AI-S-511	PA-7B-4KT
PX3061007B10GXF	30 GAL	6975	1539	9.13	192.0	AI-S-511	PA-7B-4KT

5.5 INCH BORE 7500 PSI STAINLESS STEEL PISTONS

MODEL NUMBER	NOMINAL SIZE	GAS CAPACITY	DRY WEIGHT	A (OD)	B (OAL)	MOUNTING CLAMP	SEAL KIT
		IN ³	LBS.	IN	IN		
PX2.57.51005.5B10G1FSS	2.5 GAL	596	257	7.5	36.50	AI-CLR-750-SS	PA-5.5B-7.5-4KT
PX57.51005.5B10G1FSS	5 GAL	1174	399	7.5	60.75	AI-CLR-750-SS	PA-5.5B-7.5-4KT

2.5 INCH BORE 10000 PSI PISTONS

MODEL NUMBER	NOMINAL SIZE	GAS CAPACITY	DRY WEIGHT	A (OD)	B (OAL)	MOUNTING CLAMP	SEAL KIT
		IN ³	LBS.	IN	IN		
PA.5PT101002.5B10GXF	0.5 PT	15.75	30	4	11.5	AI-CLR-400	PA-2.5B-10-4KT
PA1PT101002.5B10GXF	1 PT	30.75	37	4	14.5	AI-CLR-400	PA-2.5B-10-4KT
PA1QT101002.5B10GXF	1 QT	62.5	51	4	21	AI-CLR-400	PA-2.5B-10-4KT
PA2QT101002.5B10GXF	2 QT	123	78	4	33.5	AI-CLR-400	PA-2.5B-10-4KT
PA3QT101002.5B10GXF	3 QT	188	106	4	46.5	AI-CLR-400	PA-2.5B-10-4KT
PA4QT101002.5B10GXF	4 QT	247	132	4	58.5	AI-CLR-400	PA-2.5B-10-4KT
PA6QT101002.5B10GXF	6 QT	367	185	4	83	AI-CLR-400	PA-2.5B-10-4KT

2.5 & 3 INCH BORE 15000 PSI STAINLESS STEEL PISTONS

MODEL NUMBER	NOMINAL SIZE	GAS CAPACITY	DRY WEIGHT	A (OD)	B (OAL)	MOUNTING CLAMP	SEAL KIT
		IN ³	LBS.	IN	IN		
PA1QT151002.5B7G7FSSK	1 QT	60	71	4.6	18.75	AI-1QT-511-SS	Contact Us
PA1151003B7G7FSSK	1 GAL	231	213	5.5	41	AI-CLR-550-SS	Contact Us

Other configurations can be accommodated. Please see our piston ordering table on page 29 or contact us for more options.

COLLARS

PISTON ACCUMULATORS - MOUNTING

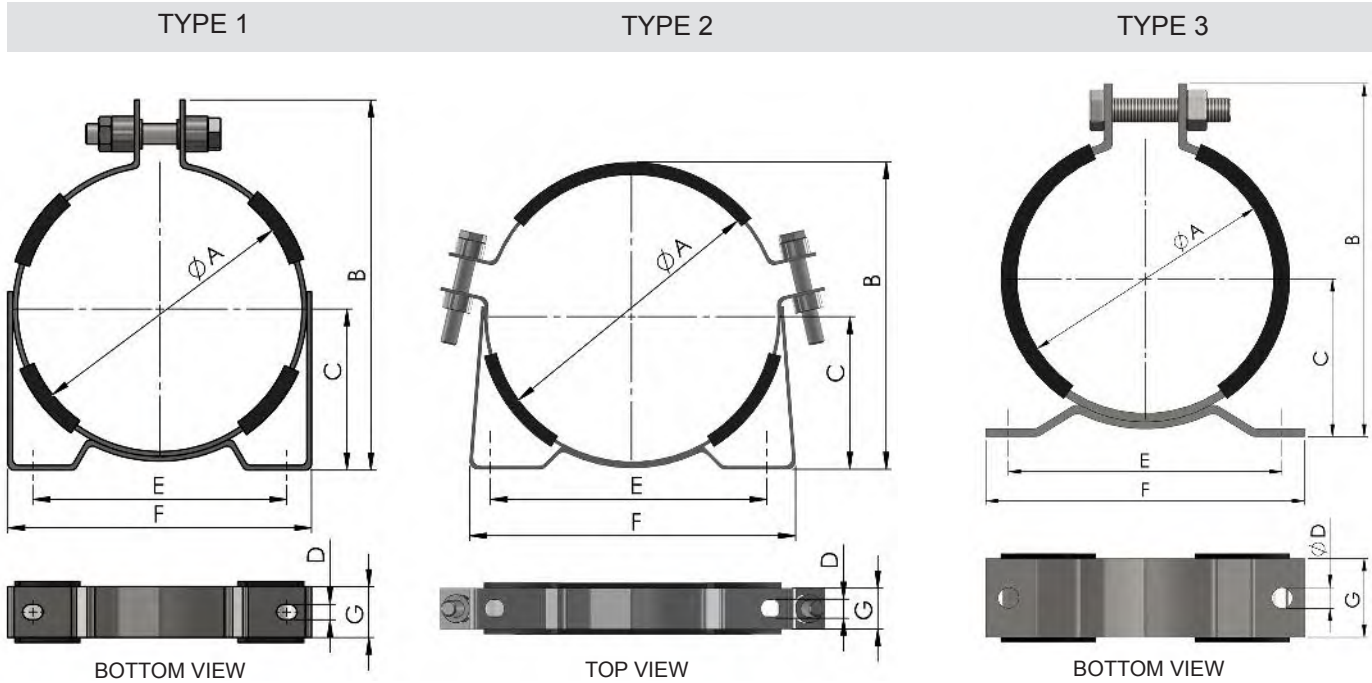

MOUNTING COLLARS FOR PISTON ACCUMULATORS										
DESCRIPTION	TYPE	PART NUMBER ZINC PLATED	PART NUMBER STAINLESS	DIMENSIONS (IN.)						
				A	B	C	D	E	F	G
2.5" Bore 10000 PSI Collar	3	AI-CLR-400	AI-CLR-400-SS	4.1	5.6	2.5	0.3	4.3	5.0	1.3
3" Bore 3000 PSI Collar	1	AI-CLR-350	AI-CLR-350-SS	3.5	4.4	2.1	0.4	3.2	5.1	1.2
4" Bore 6000 PSI Collar	1	AI-CLR-500	AI-CLR-500-SS	5.0	7.0	3.0	0.4	5.4	6.8	1.3
6" Bore 3000 PSI Collar	2	AI-CLR-650	AI-CLR-650-SS	6.5	7.5	3.6	0.4	5.8	7.2	1.2
7" Bore 6000 PSI Collar	2	AI-S-511	AI-S-511-SS	8.9	9.4	4.7	0.6	8.5	10.0	1.3
8" Bore 4000 PSI Collar	2	AI-S6-511	AI-S6-511-SS	9.4	10.3	5.3	0.3	8.5	10.4	1.5

Mounting collars are available in increments of 1/4" from 3" OD to 20" OD (AI-CLR-300 through AI-CLR-2000). Please contact us for more information.

Mounting collars are sold in kit form, including the appropriate adjustment bolts and rubber cushions. Mounting bolts are not included. Stainless collars are 300 series stainless.

These collars are mounting fasteners only and are not intended to support the entire weight of an accumulator. Contact us for specifications.



Installation, operation
Assumes no liability for
Personnel review all
Without any guidance, it
Evaluation and does
accumulators.com, for



**Manufactured
by
Accumulators, Inc.**

PREP
NOT RECHARGEABLE
CAG 450

DIAPHRAGM ACCUMULATORS



Visit accumulators.com for more information.

OVERVIEW

DIAPHRAGM ACCUMULATORS



Accumulators, Inc. diaphragm accumulators are designed primarily for pulsation dampening and low-volume fluid storage. The flexible diaphragm provides excellent gas and fluid separation, while the lightweight shell makes diaphragm accumulators a great choice for mobile markets and other applications where weight is a concern. We offer two styles of diaphragm accumulators: Fully-repairable and electron-beam welded. Both are offered with a variety of materials, options and accessories.

Sizes range from 6 to 150 cubic inches and working pressures up to 5000 psi. Our diaphragm accumulators can handle a liquid/gas ratio up to 6:1 and can be mounted in any orientation. The accumulator is typically charged with dry nitrogen gas to a set precharge determined by system requirements.

PARTS, ACCESSORIES & TOOLS

Bladder Materials & Kits	9
Tools	36
Safety Blocks	22
Nitrogen Regulators	23
Gas Valves	36
C & G Assemblies	36
Mounting	38

MAINTENANCE & SELECTION

Ordering Table	35
FAQs	47

ENGINEERING, SERVICE & TRAINING

Custom Engineering	44
Hazmat & Dot Exemption	45
Training Services	46

DIAPHRAGM ACCUMULATOR ORDERING TABLE

DIAPHRAGM ACCUMULATORS

Use the table below to determine the part number for your desired accumulator. For help sizing your accumulator, selecting a compatible elastomer, and to obtain a quote on accumulators and all our other products, visit our website at accumulators.com.

Select the desired option from each list and place the corresponding code in its proper place:

MODEL	SIZE	PRESSURE	FLUID PORT	ELASTOMER	SERVICE	EXAMPLE
AME	30	3100	3		NP	= AME3031003NP

MODEL		PRESSURE		FLUID PORT		ELASTOMER	
OPTION	CODE	OPTION	CODE	OPTION	CODE	OPTION	CODE
Repairable	AME	2000 PSI	2100	6 - 30 cu. in.; 3/4" SAE	3	Buna-Nitrile	Blank
Welded	AMW	3000 PSI	3100	45-150 cu. in.; 1-1/16" SAE	3	Hydrin/ECO	H
SIZE		5000 PSI	5100			EPR	E
OPTION	CODE					Viton	V
6 cu. in.	6					SERVICE	
10 cu. in.	10					OPTION	CODE
20 cu. in.	20					Painted	Blank
30 cu. in.	30					All Stainless	AS
45 cu. in.	45					Nickel Plated	NP
60 cu. in.	60						
85 cu. in.	85						
90 cu. in.	90						
150 cu. in.	150						

Only the most popular options are shown above. We have many more options and products available.

REPAIRABLE DIAPHRAGM ACCUMULATORS

6-150 IN³ MODELS

Part numbers below are standard carbon steel. Items are available with coatings or in stainless steel for improved corrosion resistance and diaphragm life. The models detailed below are fully repairable.

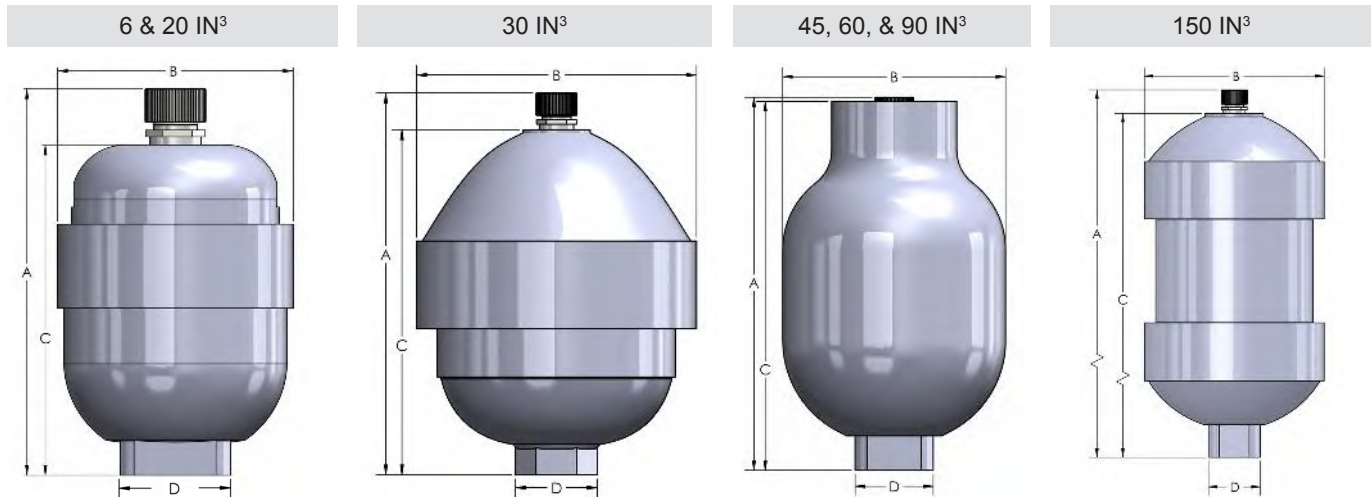

INSIDE VIEW

COMPONENT PARTS

- 1 Shell
- 2 Gas valve
- 3 Diaphragm

3000 PSI MODELS

PART NUMBER	NOMINAL SIZE (IN ³)	GAS VOLUME (IN ³)	DIMENSIONS				WEIGHT (LBS.)	STD. FLUID PORT	REPAIR KIT
			A	B	C	D			
AME631003	6	6.10	5.0	3.0	4.3	1.4	4.2	3/4"-16 SAE	AM-6-3KT
AME2031003	20	21.4	6.2	3.9	5.4	1.4	6.4	3/4"-16 SAE	AM-20-3KT
AME3031003	30	30.5	6.8	4.6	6.0	1.4	9.0	3/4"-16 SAE	AM-30-3KT
AME45TR31003	45	45.8	7.8	4.6	7.6	1.6	9.6	1-1/16"-12 SAE	AM-60-TR-3KT
AME60TR31003	60	61.0	8.5	4.6	8.3	1.6	11.0	1-1/16"-12 SAE	AM-60-TR-3KT
AME90TR31003	90	91.5	11.7	4.6	11.5	1.6	14.9	1-1/16"-12 SAE	AM-90-3KT
AME15031003	150	152.6	17.3	5.4	16.5	1.6	30.9	1-1/16"-12 SAE	AM-150-3KT

5000 PSI MODELS

PART NUMBER	NOMINAL SIZE (IN ³)	GAS VOLUME (IN ³)	DIMENSIONS				WEIGHT (LBS.)	STD. FLUID PORT	REPAIR KIT
			A	B	C	D			
AME651003	6	6.10	5.0	3.0	4.3	1.4	4.2	3/4"-16 SAE	AM-6-3KT
AME2051003	20	21.36	6.2	3.9	5.4	1.4	6.4	3/4"-16 SAE	AM-20-3KT
AME3051003	30	30.51	6.8	4.6	6.0	1.4	9.0	3/4"-16 SAE	AM-30-3KT

CHARGING & GAUGING

To charge our repairable diaphragm accumulators, use charging kit AME-CG3-3KT-SS or use adapter AME-CG-004 with our AI-CG3-3KT-SS bladder accumulator charging kit.

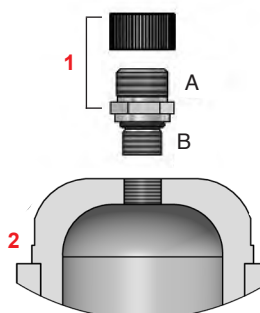
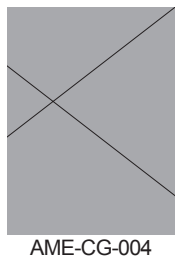

3K | 5K STANDARD GAS VALVE WITH CAPTURED O-RING SEAL

COMPONENT PARTS

ITEM	PART #	DESCRIPTION
1	AME-309-1	Gas valve assembly
2	-	Shell

THREAD SPECIFICATIONS

ITEM	DESCRIPTION
A	5/8"-18 UNF
B	M12x1.5

WELDED DIAPHRAGM ACCUMULATORS

10-85 IN³ MODELS

Part numbers below are standard carbon steel. Items are available with OD coatings or in stainless steel for improved corrosion resistance and diaphragm life. The models detailed below are non-repairable and should be replaced if no longer functioning properly.

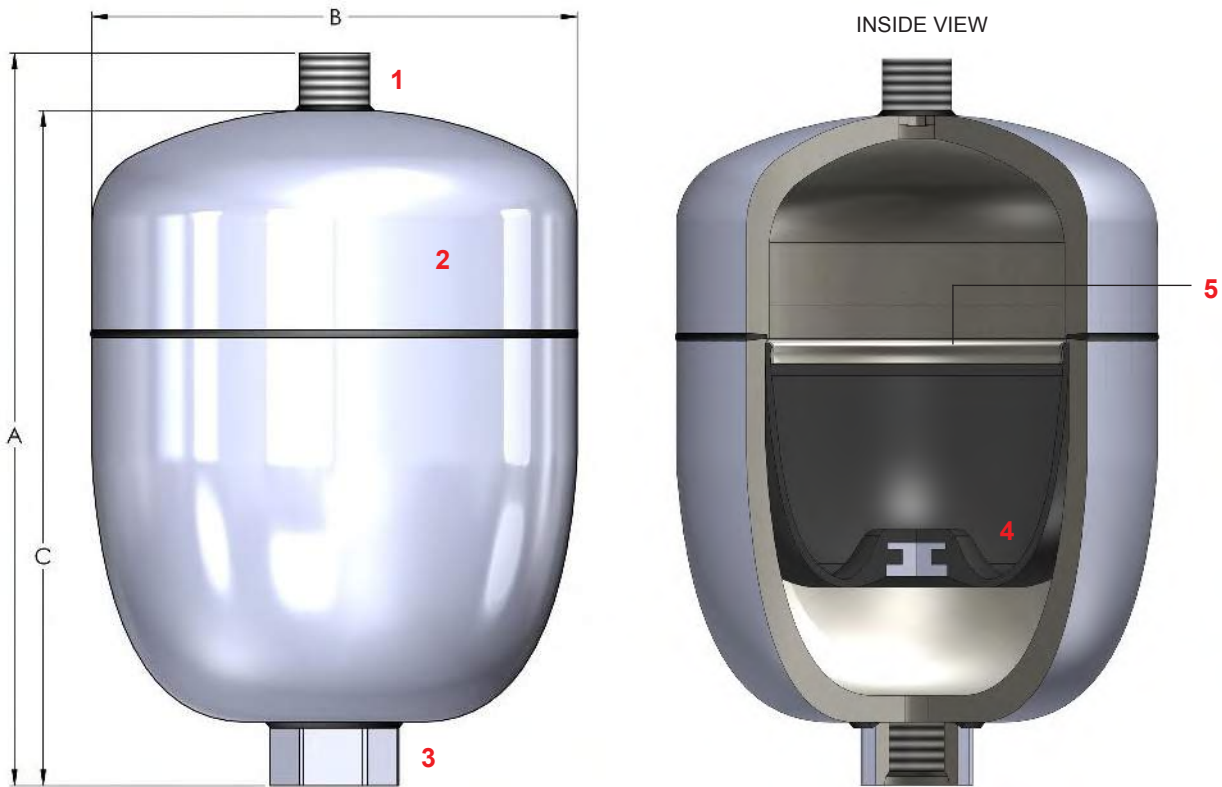

3000 & 5000 PSI MODELS							
PART NUMBER	MODEL PRESSURE	NOMINAL SIZE (IN ³)	GAS VOLUME (IN ³)	DIMENSIONS			WEIGHT (LBS.)
				A	B	C	
AMW1031003	3000	10	9.8	4.9	2.7	4.2	2
AMW2031003	3000	20	21.4	6	3.8	5.2	4
AMW3031003	3000	30	30.5	6.5	4.1	5.7	5.1
AMW4531003	3000	45	45.7	6.7	4.8	6	6.6
AMW6031003	3000	60	61.0	8.2	4.6	6.6	9.9
AMW8531003	3000	85	85.4	7.6	6	6.9	12.3
AMW6051003	5000	60	61.0	8.1	5.3	7.3	10.8

COMPONENT PARTS	
ITEM	DESCRIPTION
1	Gas port, M28X1.5, welded
2	Shell
3	Fluid port, 3/4" SAE (#8)
4	Diaphragm
5	Diaphragm supporting plate

M28X1.5 CHARGING AND GAUGING KIT



We offer two charging and gauging kits for our welded accumulators:

- AMW-CG3-3KT-SS (3000 PSI models)
- AMW-CG5-5KT-SS (5000 PSI models)

These charging kits require no additional tools or parts to precharge or check gas pressure on any M28X1.5 gas valve port.

COLLARS & CLAMPS

DIAPHRAGM ACCUMULATORS - MOUNTING

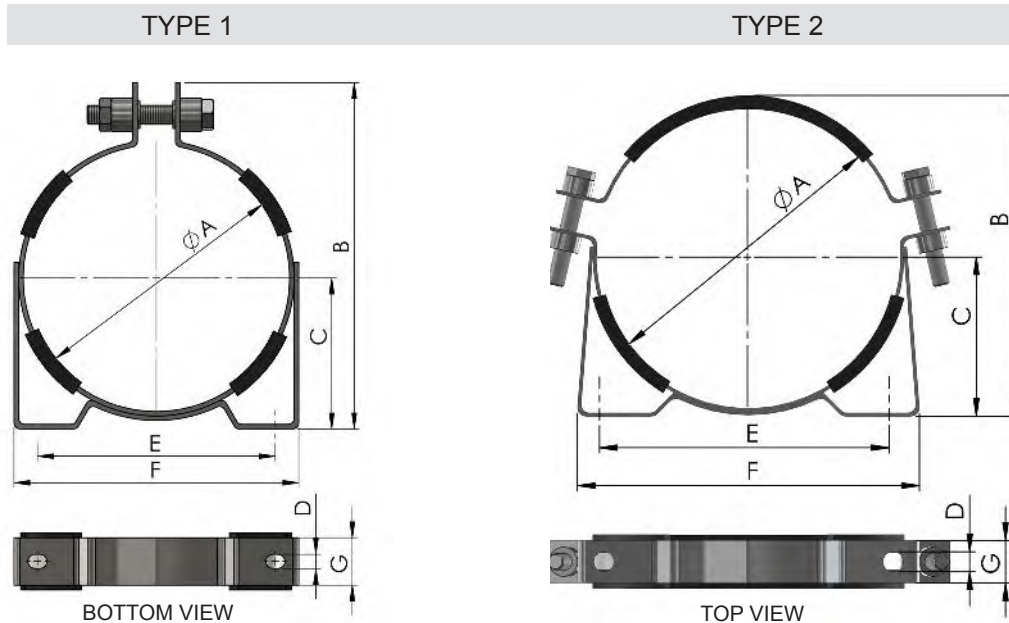

MOUNTING COLLARS FOR AME DIAPHRAGM ACCUMULATORS										
PART NUMBER ZINC PLATED	PART NUMBER STAINLESS	TYPE	FITS	DIMENSIONS (IN.)						
				A	B	C	D	E	F	G
AI-CLR-300	AI-CLR-300-SS	1	AME6, AMW10	3.1	-	1.9	0.4	3.2	-	1.2
AM-514	AM-514-SS	1	AME30	3.6	5.3	2.2	0.4	3.5	4.4	1.2
AI-CLR-350	AI-CLR-350-SS	1	AME20	3.5	4.4	2.1	0.4	3.2	5.1	1.2
AI-CLR-400	AI-CLR-400-SS	3	AMW30	4.1	5.6	2.5	0.3	3.5	5.0	1.3
AI-CLR-475	AI-CLR-475-SS	2	AME45 THRU AME150, AMW60, AMW45	4.7	-	2.7	0.4	3.9	-	1.2
AI-CLR-600	-	2	AMW85	6.1	-	3.4	0.4	5.8	-	1.2

Mounting collars available in increments of 1/4" from 3" OD to 20" OD (AI-CLR-300 through AI-CLR-2000). Contact us for more information.

NOTE: Mounting collars are sold in kit form, including the appropriate adjustment bolts and rubber cushions. Mounting bolts are not included. Standard collars and clamps are carbon steel plated with zinc. Stainless collars are 300 series stainless. These clamps are mounting fasteners only and are not intended to support the entire weight of an accumulator. Contact us for specifications.

**SPECIALTY
ACCUMULATOR
PRODUCTS AND
ACCESSORIES**



Visit accumulators.com for more information.

GAS BOTTLES

SPECIALTY PRODUCTS & ACCESSORIES

Our gas bottle is an ASME stamped, seamless pressure vessel that is used to safely hold high pressure gases or liquids. We stock several different models for rapid delivery, and we can also custom-manufacture similar vessels with a wide variety of volumes and connection sizes. Available in carbon steel or stainless steel, with or without special coatings and other options. Contact us for a quote and more information.

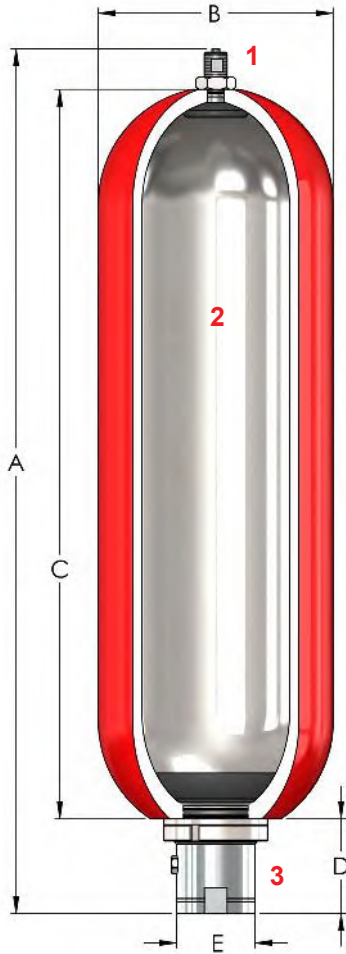

3000 PSI GAS BOTTLES

PART NUMBER	NOMINAL SIZE (GAL)	GAS VOLUME (IN ³)	DIMENSIONS (IN.)					WEIGHT (LBS.)	STD. PORT
			A	B	C	D	E		
A1QTGB3100	0.25	57	11.0	4.5	7.6	2.1	1.6	9	3/4" NPT
A1GB3100	1	231	17.0	6.7	11.0	3.5	2.4	31	1.25" NPT
A2.5GB3100	2.5	594	21.0	9.0	15.5	3.5	3.0	75	2" NPT
A5GB3100	5	1197	33.0	9.0	27.5	3.5	3.0	112	2" NPT
A10GB3100	10	2253	54.0	9.0	48.5	3.5	3.0	206	2" NPT
A11GB3100	11	2530	60.0	9.0	54.0	3.5	3.0	224	2" NPT
A15GB3100	15	3434	78.0	9.0	72.0	3.5	3.0	289	2" NPT

5000 & 6000 PSI GAS BOTTLES

PART NUMBER	NOMINAL SIZE (GAL)	GAS VOLUME (IN ³)	DIMENSIONS (IN.)					WEIGHT (LBS.)	STD. PORT
			A	B	C	D	E		
A1QTGB5100	0.25	57	11.2	4.5	7.6	2.1	1.4	9	3/4" NPT
A1GB6100	1	231	17.0	7.1	11.4	3.9	2.4	34	1.25" NPT
A2.5GB6100	2.5	594	22.0	9.6	15.5	3.9	3.0	107	2" NPT
A5GB6100	5	1197	34.0	9.6	27.5	3.9	3.0	192	2" NPT
A10GB6100	10	2253	55.0	9.6	48.5	3.9	3.0	302	2" NPT
A15GB6100	15	3434	79.0	9.6	72.0	3.9	3.0	461	2" NPT

10000 PSI GAS BOTTLES

PART NUMBER	NOMINAL SIZE (GAL)	GAS VOLUME (IN ³)	DIMENSIONS (IN.)					WEIGHT (LBS.)	STD. PORT
			A	B	C	D	E		
A2.5GB10100XS	2.5	590	22.5	11.75	17.0	3.5	3.0	320	1" MP
A5GB10100XS	5	1202	34.5	11.75	29.0	3.5	3.0	508	1" MP
A10GB10100XS	10	2256	55.5	11.75	50.0	3.5	3.0	841	1" MP
A15GB10100XS	15	3265	78.5	11.75	73.5	3.5	3.0	1214	1" MP

Part numbers above are standard carbon steel. Items are available with stainless parts and a variety of coatings. Also available in top repairable style with ports at each end. Custom 10K designs are also available.

COMPONENT PARTS

1	Stem
2	Shell
3	Port Assembly

SEAMLESS DUAL-PORT GAS BOTTLE

SPECIALTY PRODUCTS AND ACCESSORIES

Our double-necked gas bottle is an ASME stamped, seamless pressure vessel that reduces leak points and maximizes usable volume. We stock several different models for rapid delivery, and we can also custom-manufacture similar vessels with a wide variety of volumes and connection sizes. Available in carbon steel or stainless steel, with or without special coatings and other options. Contact us for a quote and more information.

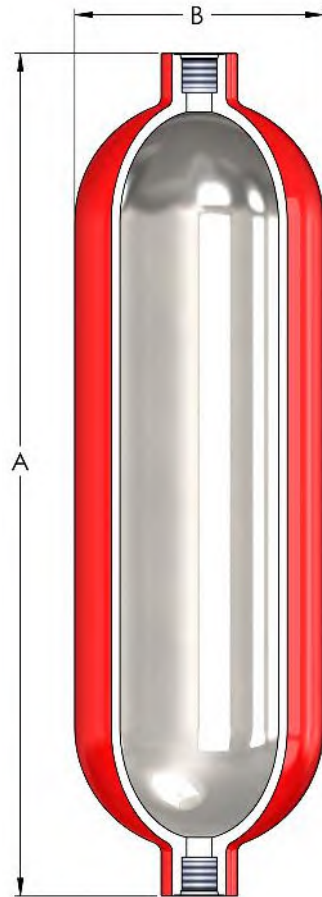

3000 PSI SEAMLESS DUAL-PORT GAS BOTTLE						
PART NUMBER	NOMINAL SIZE (GAL)	GAS VOLUME (IN ³)	DIMENSIONS (IN.)		WEIGHT (LBS.)	STD. PORT
			A	B		
AGB1QT31001G1F	0.25	69	10.0	4.5	12	SAE #8 ORB
AGB131002G2F	1	217	14.0	6.5	29	SAE #20 ORB
AGB2.531003G3F	2.5	619	18.7	9.0	64	SAE #24 ORB
AGB531003G3F	5	1240	30.7	9.0	105	SAE #24 ORB
AGB7.531003G3F	7.5	1861	42.7	9.0	146	SAE #24 ORB
AGB1031003G3F	10	2327	51.7	9.0	177	SAE #24 ORB
AGB12.531003G3F	12.5	2987	63.4	9.0	217	SAE #24 ORB
AGB1531003G3F	15	3543	75.2	9.0	257	SAE #24 ORB
AGB2031003G3F	20	4759	98.7	9.0	337	SAE #24 ORB

FLOAT ACCUMULATORS

SPECIAL PRODUCTS AND ACCESSORIES

Float accumulators are ideal for low-cycle applications requiring extreme temperatures or located in a harsh environment. Our patented technology minimizes most major causes for operational damage such as fluid contamination and insufficient maintenance. Float accumulators are particularly well-suited for subsea and offshore applications. Unlike other types of accumulators, float accumulators must be mounted vertically to function properly.

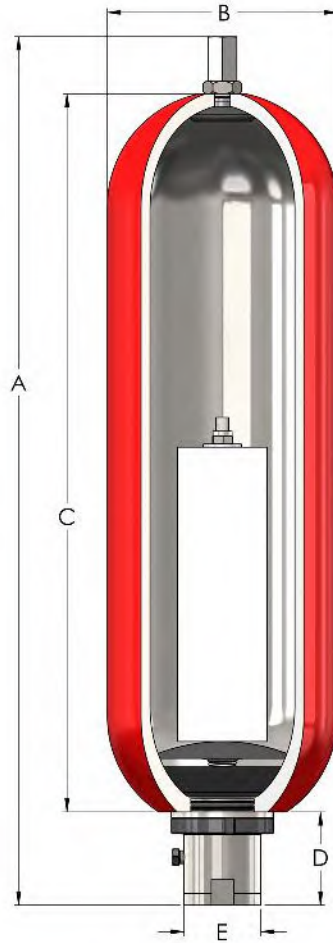

3000 PSI FLOAT ACCUMULATORS									
PART NUMBER	NOMINAL SIZE (GAL)	GAS VOLUME (IN ³)	DIMENSIONS (IN.)					WEIGHT (LBS.)	STD. PORT
			A	B	C	D	E		
A10F3100XS	10	2013	54.0	9.0	48.5	3.5	3.0	220	2" NPT
A11F3100XS	11	2267	60.0	9.0	54.0	3.5	3.0	232	2" NPT
A15F3100XS	15	2960	78.0	9.0	72.0	3.5	3.0	304	2" NPT

6000 PSI FLOAT ACCUMULATORS									
PART NUMBER	NOMINAL SIZE (GAL)	GAS VOLUME (IN ³)	DIMENSIONS (IN.)					WEIGHT (LBS.)	STD. PORT
			A	B	C	D	E		
A10F6100XS	10	2013	55.0	9.6	48.5	3.9	3.0	316	2" NPT
A15F6100XS	15	2960	79.0	9.6	72.0	3.9	3.0	476	2" NPT

Items are only available in XS, with stainless parts and special shell coatings, for improved corrosion resistance. Other fluid ports available, see page 5.

**ENGINEERING
SERVICE
SUPPORT
TRAINING**



Visit accumulators.com for more information.

CUSTOM ENGINEERING & FABRICATION

Accumulators, Inc. can design products to fit your precise requirements. We can help you select special fluid or gas ports, special elastomers, and special coatings. These products can be assigned proprietary part numbers for your exclusive use, perfect for OEM applications and new product testing.

CUSTOM ACCUMULATORS AND VESSELS

We can engineer, design and fabricate pressure vessels up to 250 gallons in many pressure ranges and configurations.

MACHINED PARTS

Accumulators, Inc. maintains a worldwide network of expert machine shops and other metalworking facilities for our various metal parts needs. Because of our extensive relationships and significant economies of scale, we have become specialists in the sourcing of machined parts. We have the capability to quote, inspect, stock and invoice for all your specialty machined parts needs, not just hydraulic parts and components. If you currently source machined parts for which you need a better price, shorter lead time or just an alternate source, please send a drawing and details to info@accumulators.com and we will do the rest. As always, all drawings will remain confidential and proprietary to your requirements only.

CARBON-FIBER WRAPPED SHELLS

For applications that require a reduced system weight, we offer accumulators manufactured with a composite overwrapped shell. These accumulators typically weigh around half of the weight of a normal carbon-steel accumulator. Please contact us for more information.



CUSTOM PRESSURE VESSELS

RACKS AND MANIFOLDS

When an application requires more auxiliary fluid volume than can be handled by a single accumulator, manifolds and bottle racks are often an efficient solution. Several accumulators can be mounted together in a parallel system that provides the necessary volume for BOP closing systems, emergency power, and other fluid storage applications.

Additionally, multiple-accumulator racks have the advantage of redundancy over a single large accumulator; if a very large accumulator goes offline, it may be weeks or months until it can be repaired or replaced. With a multiple-accumulator manifold, if one accumulator goes offline, the system can still operate near complete capacity.

Accumulators, Inc. can provide manifolds and racks to handle any number of accumulators, in any configuration desired. Additionally, our units are designed with ease of installation and repair in mind; typically arranged on an oilfield skid with easy-access lifting eyes and fork lift slots.



HAZMAT & DOT EXEMPTION

FOR ACCUMULATORS WITH NITROGEN PRECHARGE

Accumulators, Inc. has been issued a special Hazardous Materials Exemption by the U.S. Department of Transportation:

DOT-SP-9998

This exemption, and its extensions, allows Accumulators, Inc. and its subsequent authorized purchasers of Nitrogen Precharged Unmodified Accumulator Assemblies to ship via:

1. Motor Vehicle, both common carrier and private
2. Rail
3. Cargo Vessel
4. Cargo only aircraft

Subject to the following restrictions:

1. Only products manufactured by Accumulators, Inc. are approved.
2. Maximum Nitrogen precharge: 70% of MAWP.
3. All units must be properly marked, labeled, and documented.
4. Units shipped by subsequent purchasers may not be modified in any way.
5. Units precharged by subsequent owners must meet all the same shipping requirements as those units shipped from the factory.
6. All shipments must have a 24 hour emergency response phone number. Accumulators, Inc. provides this service for shipments direct from the factory. Subsequent purchasers who have registered in advance for this service may use the same number. To avoid the possibility of a large fine, we recommend the use of this low cost service.
7. This exemption does not mandate that carriers accept shipments. Individual carriers may have procedures prohibiting certain shipments. Contact your freight handler for details.
8. Shipments under "HAZMAT" rules will be at a higher freight tariff with additional costs for DOT mandated documentation.
9. A copy of the exemption must accompany all shipments.

All customers are advised to read the exemption carefully, and to review the referenced DOT regulations. These regulations apply fully to our customers and any subsequent shipper and contain training, record keeping, marking, labeling, documentation and safety rules. DOT regulations allow inspection of our customers' facilities and records if this exemption is used.

All customers and shippers are required by federal law to have a 24 hour response available for any "H" shipment. We highly recommend that customers register with an emergency response service for shipments of accumulators and other hazardous products. Please contact us for additional details.

IT IS ILLEGAL FOR ANYONE TO SHIP ANY MANUFACTURERS' PRECHARGED ACCUMULATOR WITHOUT THE PROPER HAZMAT "H" DESIGNATION, DOT EXEMPTION, DOCUMENTATION, MARKING, LABELING, TRAINING AND RECORDS.

A copy of the Accumulators, Inc. DOT Exemption is enclosed with each "H" shipment. Additional copies may be downloaded at accumulators.com.

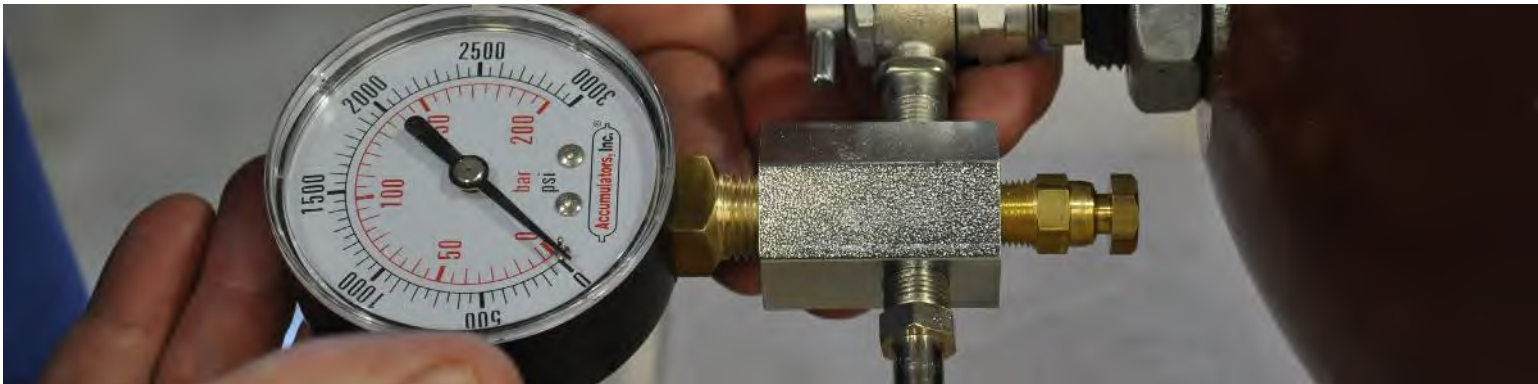

HANDS-ON TRAINING

At Accumulators, Inc., we offer hands-on training in accumulator repair and maintenance, providing customers with the opportunity to gain valuable knowledge about the care and maintenance of their accumulators. While most courses are conducted at our Houston, Texas facility, we do offer customer-site training upon request. Our most requested training courses include:

- Basic Accumulator Training
- Accumulator Application Training
- Accumulator Sizing Training
- Accumulator Repair, Maintenance, Training and Troubleshooting

We also offer a corporate overview seminar, Intro to Accumulators, Inc., designed to introduce new customers and distributors to our company.

WEBINARS

In addition to hands-on training, we offer webinars on many popular subjects and products, providing customers with an easily-accessible platform to gain useful knowledge about their accumulators and accumulator products. We can also host a webinar tailored per customer request, offering a unique and individually-dedicated session where specific topics can be explored and discussed. This is a good opportunity to train sales representatives in multiple branch/field locations without the costs of centralized training.

To schedule a training course or webinar, please contact our sales department.

FREQUENTLY ASKED QUESTIONS

SPECIALTY PRODUCTS & ACCESSORIES

1. WHAT ARE THE ADVANTAGES OF BLADDER ACCUMULATORS OVER PISTON ACCUMULATORS?

- Rapid response to pressure changes and work cycle
- Complete separation of gas and fluid
- Highly resistant to fluid contamination
- Low maintenance, trouble-free operation
- Readily available, low cost replacement parts
- Eliminates costly down time on expensive systems due to simple repair

2. WHAT ARE THE ADVANTAGES OF PISTON ACCUMULATORS OVER BLADDER ACCUMULATORS?

Piston accumulators are highly customizable and can handle much larger volumes, higher pressures and higher temperatures than many bladder accumulators. Additionally, a wider tolerance for initial precharge setting allows for a higher fluid-to-gas ratio for certain applications.

3. WHEN SHOULD A DIAPHRAGM ACCUMULATOR BE SELECTED OVER A BLADDER OR PISTON ACCUMULATOR?

Diaphragm accumulators are typically used for pulsation dampening applications where smaller accumulators are sufficient to get the job done. Additionally, diaphragm accumulators are typically less expensive than other types of accumulators, but are often not as customizable.

4. HOW DOES A BLADDER ACCUMULATOR WORK?

A bladder accumulator features a seamed molded rubber bladder which is mechanically attached to the gas end of a high-strength metal shell. The flexible bladder provides excellent separation between the gas side of the accumulator and the fluid side or provides a transfer barrier between two fluids. The bladder accumulator is typically charged with dry nitrogen gas to a set precharge pressure determined by the application requirements. As system pressure increases, the rubber bladder flexes to accommodate hydraulic fluid while compressing the nitrogen; as system pressure returns to normal, the nitrogen expands and the bladder returns to its previous position.

5. HOW DOES A PISTON ACCUMULATOR WORK?

A piston accumulator consists of a sealed cylindrical body with a polished and honed ID surface and with fluid or gas porting at each end. A lightweight floating piston separates the gas side of the accumulator from the fluid side or provides a transfer barrier between two fluids. The piston accumulator is charged with dry nitrogen gas to a set precharge pressure determined by the application requirements. As system pressure increases, the piston moves along the cylinder tube compressing the nitrogen, or in the opposite direction as system pressure returns to normal and thus discharging fluid from the accumulator.

6. HOW DOES A DIAPHRAGM ACCUMULATOR WORK?

A diaphragm accumulator features a one-piece molded rubber diaphragm which is mechanically sealed by a high-strength metal shell. The flexible diaphragm provides excellent separation between the gas side of the accumulator and the fluid side or provides a transfer barrier between two fluids. The diaphragm accumulator is charged with dry nitrogen gas to a set precharge pressure determined by the application requirements. As system pressure increases, the rubber diaphragm flexes to accommodate hydraulic fluid while compressing the nitrogen; as system pressure returns to normal, the nitrogen expands and the diaphragm returns to its previous position.

7. ARE ACC INC ACCUMULATORS INTERCHANGEABLE WITH OTHER MANUFACTURERS' ACCUMULATORS?

Accumulators, Inc. bladder accumulators and components are typically interchangeable with those supplied by other manufacturers. In some cases, standard ACC INC bladder accumulator parts are of newer design and may not be fully interchangeable; however, we can often provide parts for older and non-standard designs.

Many of our piston and diaphragm accumulators have the same or similar dimensions to our competitors' units. We can also custom engineer and manufacture an exact fit if needed. The sub-components of our piston and diaphragm accumulators however are typically not interchangeable.

We maintain an extensive cross-reference of our competitors' products at accumulators.com.

8. WHY USE DRY NITROGEN GAS (N₂)?

Nitrogen is a non-toxic, inert, non-explosive, and non-flammable gas that is readily available at reasonable costs.

WARNING! NEVER USE SHOP AIR OR OXYGEN! Shop air has oxygen and when exposed to petroleum-based fluids or grease, can diesel (explode) under pressure. Pure oxygen is even more volatile. Other gases are expensive, corrosive or explosive. **WARNING! THE USE OF HELIUM IS NOT RECOMMENDED.** Helium has several characteristics that can cause system failures. Gas leakage, explosive thermal expansion and a negative Joule-Thomson coefficient are all causes for major concern. ACC INC recommends only dry nitrogen gas be used to precharge accumulators. For more information, please contact us for our full study on the Usage of Helium in Hydropneumatic Accumulators.

Several grades of nitrogen gas are available. For use in our accumulators, we recommend Commercial/Industrial

FREQUENTLY ASKED QUESTIONS

grade. This is the most common grade available and the most cost effective. It has been used with accumulators for over 75 years. The average purity is 99.5%. Higher grade gas is acceptable. The N2 MSDS is available from the factory at no cost.

While nitrogen is non-explosive, it is still very dangerous at high pressures. Ensure all personnel working with pressurized vessels receive proper training and follow all safety guidelines.

9. WHAT IS THE CORRECT PRECHARGE FOR AN ACCUMULATOR?

Each application has different pre-charge requirements. Our online Sizing Tool at accumulators.com can help calculate the optimum accumulator precharge for your application. You can also contact our sales department for further assistance.

10. WHAT IS THE PROPER DIRECTION TO MOUNT AN ACCUMULATOR?

The preferred orientation for a bladder accumulator is vertical; however, horizontal mounting is acceptable with a small loss of efficiency when lubricated properly. Piston and diaphragm accumulators can be mounted in any direction. Float accumulators MUST be mounted vertically. ACC INC recommends bolting the accumulator to the skid unit using approved mounting brackets.

11. DO ACC INC PRODUCTS MEET ANY THIRD PARTY CODES?

Most ACC INC bladder and piston accumulators are designed to the strict guidelines of the ASME Boiler and Pressure Vessel Code, are witnessed and stamped with the ASME symbol and are registered with the National Board of Boiler and Pressure Vessel Inspectors. Many other design approvals or authority reviews, such as CE, DNV, ABS, CRN, Lloyds, NR-13, AS1210, etc. are available by request at additional cost. We can also modify existing units under the National Board Inspection Code "R" stamp.

Our diaphragm accumulators are designed according to CE guidelines, and are available with third party certifications/design approvals at additional cost.

12. DOES ACC INC PERFORM RECERTIFICATION OF ACCUMULATORS?

We can perform a variety of NDA (non-destructive) stress tests on in-service accumulators such as hydraulic pressure testing, magnetic particle testing, visual inspection, and ultrasonic testing along with repair and refurbishment of substandard components. Our engineering department can prepare documentation required to meet a third party accumulator recertification standard.

13. WHAT TYPE OF TESTING DO ACC INC ACCUMULATORS RECEIVE?

ACC INC pressure vessels are subject to many rigorous tests such as high-pressure hydraulic testing, magnetic particle testing, chemical analysis, physical analysis, hardness testing, Charpy test analysis, and dimensional inspections. Other tests are available at additional cost.

14. DOES ACC INC HAVE A QUALITY CONTROL PROGRAM?

Yes, Accumulators, Inc. is an ISO 9001:2008 certified company with an extensive quality control program periodically reviewed and approved by local, state, national and international agencies. All code designs, code quality control records, quality control manuals and procedures are open to authorized inspectors.

Our main facility in Houston, Texas is approved by ASME to affix the "U" and "R" stamps and is authorized to register vessels with the National Board of Boiler and Pressure Vessel Inspectors. Our facility also has approved Manufacturing Assessments by DNV and ABS.

15. ARE CERTIFICATIONS & TRACEABILITY AVAILABLE?

ASME U-1A data reports are available upon request at no charge. Certifications or material certificates appropriate to the respective code are available at additional cost. Most accumulator shells are traceable to the day of manufacture, bladders to the month of manufacture and other components on a case-by-case basis. All vessels are registered with the National Board of Boiler & Pressure Vessel Inspectors.

16. ARE ACC INC PRODUCTS COVERED BY ANY WARRANTIES?

Yes, we believe that the ACC INC product warranty is the strongest in the industry. Our full warranty is located at accumulators.com.

17. WHEN SHOULD I USE A SAFETY BLOCK?

Accumulator safety blocks, or isolation valves, can be used in virtually any application. For absolute safety, there is no better method than the use of a safety block to isolate a charged accumulator. Because an accumulator stores a tremendous amount of power in a relatively small volume, safety blocks are always a smart option for the safety of operation personnel and maintenance technicians. Additionally, safety blocks can eliminate costly system downtime by allowing technicians to remove a single accumulator from a rack without having to shut down the entire manifold.

18. WHAT FLUID PORT THREADS ARE AVAILABLE?

NPT is standard for bladder accumulators while SAE is standard for piston and diaphragm accumulators. We

offer many other thread types and sizes from stock or as a special order. See catalog pages 5, 29 and 35 for a list of our most common options.

19. HOW OFTEN SHOULD THE PRECHARGE BE CHECKED WHILE THE ACCUMULATOR IS IN SERVICE?

If the accumulator is on a high cycle application it should be checked at least weekly. If the accumulator is used for emergency standby or pressure holding, it should be checked at least monthly. For remote or difficult to access locations, electronic permanent mount pressure monitoring has many advantages. Contact the Accumulators, Inc. sales department for further information.

20. HOW DO I PRECHARGE AN ACCUMULATOR?

Use a genuine Accumulators, Inc. C&G assembly and a regulator to slowly pre-charge the unit to 35 psig. This is the most critical part of the precharge procedure. Next, you may begin to charge your unit to the pressure required to operate appropriately. Consult the instructions listed on the accumulator, shipped with replacement bladder kits or online at accumulators.com.

21. CAN ACC INC MAKE SPECIAL ACCUMULATORS FOR MY APPLICATION?

Yes. We're experts in special orders design and manufacturing. Among our clientele are Fortune 500 companies, government agencies and the military. Each design is proprietary to the customer.

22. DOES ACC INC ACCEPT CREDIT CARDS?

We accept Visa, MasterCard, American Express and Discover.

23. HOW CAN I REQUEST A QUOTE?

Use our RFQ tool at accumulators.com to receive price and availability on any of our products. Of course you can always call us at 713-465-0202, fax us at 713-468-1618 or email us at info@accumulators.com.

24. IS ACCUMULATORS, INC. ECO-CONSCIOUS?

Our manufacturing process produces no pollution and uses only minimal electricity. In addition, we recycle cardboard, office paper, junk mail, glass, plastic, packing materials, and aluminum. Employees are encouraged to bring their recyclables from home as well. We pride ourselves on being Earth-friendly.

On-site



Accumulator Repair for bladder, piston and diaphragm accumulators.

Save Time, Save Money, In 4 Steps.



1 | Accumulator



2 | Call Accumulators,



4 | Accumulator



3 | Accumulators, Inc.



Call 713-465-0202 to speak with one of our accumulator specialists to schedule an appointment.

**SALES TERMS &
CONDITIONS**

**ORIGINAL EQUIPMENT
LIMITED WARRANTY**

INDEX



Visit accumulators.com for more information.

TERMS & CONDITIONS

TERMS AND CONDITIONS OF SALE (THE "TERMS OF SALE") BY ACCUMULATORS, INC. AND/OR ITS AFFILIATES ("SELLER") INCLUDING LIMITED WARRANTY AND DISCLAIMER OF CERTAIN LIABILITIES.

UPON THE PLACEMENT OF ANY ORDER, REGARDLESS OF MANNER IN WHICH RECEIVED, THE FOLLOWING TERMS AND CONDITIONS SHALL APPLY (THE PARTY PLACING SUCH ORDER BEING HEREIN REFERRED TO AS "BUYER") UNLESS SELLER AND BUYER HAVE PREVIOUSLY AGREED TO OTHER TERMS AND CONDITIONS BY A SIGNED WRITTEN CONTRACT BETWEEN THEM.

1. SPECIFICATIONS.

The accumulator products and other items sold by Seller hereunder, or otherwise provided by Seller, shall be referred to as the "Goods". The Goods shall conform to Seller's standard specifications, unless otherwise requested by Buyer, and were produced in compliance with the requirements of the Fair Labor Standards Act of 1938, as amended. All Goods, including those produced to meet an exact specification, shall be subject to Seller's tolerances and variations consistent with good practice in respect to (a) dimension, weight, straightness, section, composition and mechanical and/or physical properties; (b) normal variations in surface and internal conditions and in quality; (c) deviations from tolerances and variations consistent with practical testing and inspection methods; and (d) regular practice on, over and under shipment.

2. DELIVERY, PAYMENT.

Should Buyer wrongfully fail to accept or pay for any shipment or delivery, Seller may, without prejudice to any other lawful remedy, defer further shipments or deliveries until acceptance thereof or until payment is made by Buyer. Seller may from time to time demand different terms of payment from those specified in Section 4 hereafter whenever it reasonably appears that Buyer's financial condition requires such change; and may demand assurance of Buyer's ability to pay whenever it reasonably appears that such ability is in doubt. If Buyer shall fail to make any payments in accordance with the terms and conditions hereof, or shall fail to comply with such demand by Seller, Seller may, at its option, treat such failure or refusal as a repudiation hereof. Interest at the maximum rate allowed by law may be charged on past due accounts. Unless otherwise expressly provided and accepted in writing by Seller, delivery terms are F.O.B. Seller's plant. The Goods will be deemed delivered to Buyer at the plant in good condition and properly consigned. Buyer shall pay any charges at the delivery point for spotting, switching, handling, storage and other accessory services and demurrage. Seller shall have the right to assess storage and handling charge for goods left in Seller's possession after notification to Buyer that the Goods are available to ship. It will be Buyer's risk upon such delivery, and prepayment or allowance or freight by Seller shall not affect this provision. Seller shall not be liable for any injury, loss or damage resulting from the handling or the use of the Goods after such delivery. Title to the Goods shall pass to Buyer upon Seller's receipt of full payment for the Goods.

3. PRICE CHANGES, ACCEPTANCE; ACKNOWLEDGMENTS.

All catalog prices are subject to change at any time without prior notice, and billing will be at the price in effect on the day the written order acknowledgment of the Goods is sent to Buyer, less any discount available on such date. Prices quoted pursuant to a written quotation will not be subject to change for a period of 45 days, unless otherwise noted thereon. Placement of an order by Buyer will constitute an offer in accordance with the terms hereof and such offer, upon Seller's acceptance at Houston, Texas, will constitute the agreement between Buyer and Seller. Buyer's order after such acceptance by Seller will not be subject to cancellation, change or reduction in amount, or suspension by Buyer of deliveries, unless prior to such action Buyer has obtained the written consent of Seller. Upon acceptance by Seller, Seller will provide Buyer with a written acknowledgment of such order by electronic transmission or confirmed facsimile transmission and Buyer will notify Seller of any discrepancies in such acknowledgment by 5:00 p.m. Central Standard Time the following business day.

4. TERMS OF PAYMENT; FREIGHT.

Terms to Buyer are net 30 days upon approved credit unless other terms are quoted or noted on written acknowledgment. Seller shall at all times be entitled to require from Buyer all the payment guarantees it may deem necessary, including but not limited to UCC financing statements to perfect Seller's purchase money security interests. In the event of non-payment by Buyer, Buyer agrees to pay to Seller (i) all costs of collection and incidental damages incurred by Seller, including, but not limited to, reasonable attorneys' fees and expenses; (ii) any commercially reasonable charges, expenses or commissions incurred in stopping delivery; (iii) additional transportation charges; and, (iv) Seller's net additional expense incurred for the care and custody of the Goods in connection with their return or resale. In the event of any claim or legal action brought by Buyer for any cause whatsoever, Buyer shall have no rights of retention or set-off. Seller shall have the right to set-off against any monies due Seller hereunder any obligations of Seller or its affiliates to Buyer.

Buyer is responsible for all freight charges and Seller shall determine in its sole discretion the method of shipment of the Goods to Buyer. Seller will use reasonable efforts to follow delivery requests made by Buyer, but shall not be liable for any failure to follow such requests. Shipment in installments is permitted. Seller will use reasonable efforts to comply with Buyer's requests regarding transportation, but Seller reserves the right to make alternate transportation arrangements, even if at a higher cost to Buyer, if the transportation specified by Buyer is deemed by Seller to be unavailable or unsatisfactory.

5. DELIVERY DATES, RUSH ORDERS; DEFERRALS.

It is understood and agreed that deliveries of Goods will be made in accordance with Seller's regular production schedule. Further, any dates or schedules which may be specified for the delivery of the Goods have been stated only approximately and are estimated from the date

of receipt of Buyer's order and the acknowledgment, together with completed information as reasonably requested by Seller, including, but not limited to, specifications of Buyer, in order to proceed with the manufacture and or order of the Goods. Seller shall not incur any liability, either direct or indirect, nor shall any order be canceled because or as a result of any delays in meeting such dates or schedules. Seller will use reasonable efforts to meet Buyer's requests for rush deliveries. Upon any requests for rush deliveries, Seller shall use its best efforts to ship Goods within seventy-two (72) hours from the receipt of the order for Goods, provided, however, that Seller will not be liable for damages or be deemed to be in default by reason of any failure to deliver within such time or other delay in delivery. Buyer must pay for all charges determined by Seller for such rush delivery requests, including freight charges, provided that in the event delivery is not made within the seventy-two (72) hour time period, Buyer will not be liable for additional rush delivery charges. In the event that Buyer requests a deferral of shipment or manufacture of any Goods ordered, Buyer will be responsible for the payment of a fee determined by Seller in its sole discretion for such deferral.

6. RESULTS OF CANCELLATIONS.

Any cancellations of orders prior to shipment of Goods to Buyer shall result in a cancellation charge to Buyer equal to 15% of the total purchase price, in the event that the Goods are listed in the currently published catalog of Seller. Any cancellations of orders after the time period provided Buyer for advising of acknowledgment discrepancies, as provided in Section 7 below, shall result in a cancellation charge of 50% of the total purchase price for Goods not listed in the currently published catalog of Seller, including, but not limited to, special orders and Goods manufactured in accordance with Buyer specifications. Any and all cancellations at any time shall be granted at Seller's sole discretion and with Seller's written consent as set forth in Section 3 hereof.

7. INSPECTION.

Upon delivery of the Goods to Buyer, Buyer shall immediately inspect the Goods at its own cost and, if the Goods do not conform to the description contained in the acknowledgment (referred to in Section 3 herein) herein or to specification or warranty, it shall give written notice to Seller within ten (10) days after that arrival, of any claim to that effect, specifically setting forth the details of the claim. Buyer's use of the Goods in its production operations shall be deemed an acceptance of the Goods as conforming to the agreement between Buyer and Seller. Failure of Buyer to give Seller such notice shall constitute an irrevocable acceptance of the Goods by Buyer, and Buyer shall be bound to pay the full price of the Goods. The Goods shall not be returnable to Seller after acceptance (unless the return is for nonconformity of the Goods following timely notice as described above) without Seller's written consent, and any return to which Seller consents shall be subject to a handling charge of 15% of invoice price; provided, however, that if such Goods are not of current design return of such Goods to which Seller consents shall be subject to a charge of 50% of invoice price. No credit will be issued for any Goods not listed in Seller's current published catalog. No claims will be recognized in regard to Goods disposed of or returned without Seller's written consent.

8. ORIGINAL EQUIPMENT LIMITED WARRANTY

(a) For a period of one year from the date of shipment, Seller warrants purchased Goods will be free from defects in materials and workmanship in normal use and service. In the event of failure of the Goods to conform to this warranty, Seller will at no cost to Buyer, at Seller's option either repair the Goods or furnish a replacement for the Goods after test and examination by Seller demonstrates that the Goods are in breach of the above warranty. All costs incurred for the installation, removal, or reinstallation are Buyer's responsibility. To make a warranty claim, Buyer must obtain a return form from Seller and return the Goods freight prepaid to Seller at, 18435 Morton Road Houston, TX 77084 within thirty days after the defect is discovered with a letter specifying the nature of the failure of the Goods to conform to the warranty and a service purchase order to cover any non-warranty repairs. Buyer will be responsible for all insurance and freight or other transportation charges to Seller's factory. If test and examination by Seller demonstrates that the purchased Goods are in breach of warranty, the repaired Goods or replacement Goods will be returned to Buyer freight prepaid. Otherwise, the Goods that were returned to Seller will be reshipped to Buyer freight collect. **THIS WARRANTY EXCLUDES AND DOES NOT COVER DEFECTS, MALFUNCTIONS, OR FAILURES OF THE GOODS CAUSED BY REPAIRS BY PERSONS NOT AUTHORIZED BY SELLER; USE OF THE GOODS WITH UNAUTHORIZED PARTS OR ACCESSORIES; MISHANDLING; IMPROPER INSTALLATION; MODIFICATIONS OR ACCIDENTAL DAMAGE WHILE IN THE POSSESSION OF BUYER; FAILURE OF BUYER TO PROVIDE REASONABLE AND NECESSARY MAINTENANCE; MISUSE OF THE GOODS. NO WARRANTY OF MERCHANTABILITY, FITNESS FOR ANY PARTICULAR PURPOSE OR OTHER WARRANTY (WHETHER EXPRESS, IMPLIED OR STATUTORY) IS MADE BY SELLER, EXCEPT AS STATED IN THIS SECTION 8.** These Terms of Sale are a complete and exclusive statement with respect to warranties and remedies for breach of warranty between Seller and Buyer. These warranties cannot be varied, supplemented, qualified or interpreted by any prior course of dealing between Seller and Buyer or by any usage of trade. These warranties and remedies can only be varied or amended by a writing executed by Seller and Buyer which shall quote the provisions hereof which are to be amended and the provisions substituted therefore.

(b) Except for the express warranties provided in Paragraph (a) immediately above, all warranties, whether express or implied, all guarantees, and all representations as to the performance or any other aspect of the Goods, including all warranties which, in the absence of this provision, might arise from course of dealing or custom of trade, and INCLUDING ALL WARRANTIES, EXPRESS OR IMPLIED, OF MERCHANTABILITY OR

TERMS & CONDITIONS

FITNESS FOR A PARTICULAR PURPOSE, with respect to the Goods, ARE EXPRESSLY EXCLUDED AND DISCLAIMED BY SELLER. No agent, employee or representative of Seller has any authority to bind Seller to any affirmation, representation or warranty relating to the Goods other than as specifically provided herein.

(c) Neither Seller nor its affiliates shall have any warranty obligations with respect to the Goods or any part thereof which (i) is normally consumed in operation, (ii) has a normal life inherently shorter than the warranty period specified herein, (iii) is not properly stored, installed, maintained or repaired, or is modified other than pursuant to Seller's instructions or approval, or (iv) has been subjected to any other kind of detrimental exposure, or has been involved in an accident for which Seller could not be responsible. Any technical advice provided by Seller with respect to the use of the Goods shall be for informational purposes only, and Seller makes no representation or warranty nor assumes any obligation or liability for such advice.

(d) **NOTWITHSTANDING ANYTHING CONTAINED HEREIN TO THE CONTRARY, WHERE ANY GOODS SOLD BY SELLER OR ITS AFFILIATES ARE MANUFACTURED BY A THIRD PARTY AND ARE RESOLD OR DISTRIBUTED BY SELLER OR ITS AFFILIATES AND ARE LABELED ON SUCH GOODS AS SUCH, NEITHER SELLER NOR ITS AFFILIATES SHALL HAVE ANY WARRANTY OBLIGATIONS WITH RESPECT TO SUCH GOODS AND ALL WARRANTY, IF ANY, SHALL BE AS PROVIDED BY, AND ALL LIABILITY SHALL LIE WITH, THE MANUFACTURER OF SUCH GOODS ONLY.**

(e) Seller shall not be liable for any loss or damage, including special, punitive, indirect or consequential damages (including downtime) caused by its breach of any of these Terms of Sale or otherwise relating to or arising out of the Goods (including the use, manufacture, condition, delivery or presence thereof or any other matter, service or activity relating thereto, whether caused by Seller's breach of contract, negligence or other tortious conduct, or otherwise). The liability of Seller for defective or undelivered Goods and/or the consequences thereof shall be limited solely to (at Seller's option) replacement of the Goods or giving Buyer a credit or refund in the amount of the contracted price of the affected Goods. Except for the said replacement or refund, Seller shall not be liable to Buyer or any other person for, and (unless the same are caused solely by the gross negligence or willful misconduct of Seller) Buyer shall indemnify Seller with respect to any loss, injury (including death) or damage to person or property, and all claims and expenses relating thereto, arising out of or relating in any way to the Goods or the non-delivery thereof. Items not manufactured by Seller (including third-party goods on which Buyer may conduct repairs or service), or repairs or service not conducted by Seller, are guaranteed only in the manner and to the extent guaranteed by the actual manufacturer or service provider, and then only to the extent that Seller is reasonably able to enforce it, and such items, goods, or repairs are not subject to the warranties given by Seller to Buyer in this Section 8.

(f) If Buyer resells the Goods, the terms of this Section 8 shall be incorporated into the agreed terms of such resale. If Buyer fails to do so, Buyer shall indemnify Seller for any and all demands, claims, suits, damages, losses, judgments and liabilities, including, reasonable attorneys' fees, expenses and other costs of litigation, fines, penalties, or assessments asserted against Seller, in excess of that stipulated in this Section 8.

(g) Buyer designed specified, manufactured or supplied goods. The seller expressly disclaims any and all liability for the proper design, manufacture, or operation of any goods, parts or components designed, manufactured or supplied by the Buyer to the Seller; Or, third party parts specified by buyer. This includes any design, modification or addition to Seller's Product that is provided by the Buyer to the Seller, whether or not Seller has agreed to such Buyer's design, modification or addition. Further, Seller expressly does not warrant or accept liability for the goods so designed, modified or added to Seller's Goods. Seller's liability and warranty in all cases is limited to goods of Seller's design and manufacture only, as per the paragraphs above.

(h) The remedies of Buyer provided for in these Terms of Sale shall be exclusive and shall be the sole remedies of Buyer.

9. LIMITATIONS ON INTENDED USERS, COMPLIANCE WITH LAWS.

(a) Except as expressly provided by Seller in writing, the Goods are intended for ultimate purchase and use by commercial or industrial users only, and only for operation by persons trained and experienced in the use and maintenance of the Goods. The Goods are NOT intended for consumer use, and Seller's warranties do not extend to, and no Buyer is authorized to extend them to, any consumer or other customer.

(b) Buyer shall comply with all laws, ordinances, rules and regulations (including permit requirements) now in force or hereafter adopted which relate to the Goods or to the purchase, storage, sale or use thereof, or any other matter relating thereto.

(c) Operation of any of Seller's products or components beyond the prescribed working pressure limitations, or failure to observe all operating instructions stamped, attached or affixed to the product or contained in service instructions, or inappropriate installation or use in aircraft is prohibited and expressly voids any warranty.

(d) The Buyer is the sole responsible party to ensure the proper selection, installation, operation and maintenance of the Goods. Seller expressly assumes no liability for the Buyer's application. If Seller has provided any guidance, it is of a general nature based on similar applications or theoretical evaluation and does in no way warrant any specific usage. As with all hydraulic products, the correct selection, installation, operation and maintenance

of accumulators by qualified personnel is solely the Buyer's responsibility.

(e) THE USE OF ANY GASES OTHER THAN DRY NITROGEN GAS FOR OPERATION OF ANY OF SELLER'S PRODUCTS EXPRESSLY VOIDS ANY WARRANTY, ALL PRODUCTS LIABILITY AND MAY BE DANGEROUS TO LIFE AND PROPERTY.

(f) Seller expressly prohibits the use of any of its products in aircraft of any type, medical and life saving devices, nuclear facilities, in products containing volatile or corrosive liquids and gases not previously approved as noted in our compatibility lists and usage in any other non-commercial or industrial devices.

(g) Seller will be the sole entity to determine if an intended application is a warranted use. At Buyer's request Seller will provide a written statement regarding the acceptance or disapproval of a buyer's intended use.

10. INDEMNIFICATION.

Buyer shall indemnify, defend and hold Seller, its agents, representatives, officers and employees harmless from and against all claims, suits, judgments, costs, fines, damages, actions of any kind, losses, expenses (including attorney's fees) and liabilities from infringement (actual or claimed) of patents, inventions, designs, copyrights or trademarks arising from the manufacture, either whole or in part, to Buyer's design, plan, specifications or instructions. Buyer acknowledges that it has a superior knowledge of the ultimate use of the Goods and that Buyer acts as a "learned intermediary" in regards to such ultimate use. Buyer warrants that it shall save, indemnify, defend and hold harmless Seller and its affiliates (and each of their successors and assigns) and their respective directors, officers, employees and agents, from and against all demands, claims, suits, damages, losses, judgments and liabilities of whatever kind or nature, including, without limitation, reasonable attorneys' fees, expenses and other costs of litigation, fines, penalties or assessments asserted against or suffered by the indemnitee by reason of, arising out of, or in any way related to Buyer's use (or any subsequent end-user's use) of the Goods, or Buyer's negligence or willful misconduct. Buyer shall indemnify and hold harmless Seller and its affiliates from, against, for and in respect of any claim, loss, liability or damage asserted against Seller (including any of its affiliates): (i) by any third party in excess of the limitations of liability set forth under Section 8 above, or (ii) due in whole or in part to the negligence or willful misconduct of any other supplier of goods upon which services are performed at the request of Buyer. Seller makes no representation or warranty that any such Goods will not infringe outstanding patents or other rights of others.

11. FORCE MAJEURE.

Seller will not be liable for damages or be deemed to be in default by reason of any failure to deliver or delay in delivery due to any cause beyond Seller's control, including, but not limited to, fire, storm, earthquake, flood, war, acts of public enemies, rebellion, insurrection, sabotage, epidemic, quarantine restrictions, embargo, labor difficulty, railroad car shortages, interruption of transportation, accident, explosion, riots, laws, rules, regulations, instructions and orders of any governmental authority, or any and all acts of God.

12. TAXES.

Seller's prices do not include sales, use, excise or similar taxes. Consequently, in addition to the price specified herein, the amount of any present or future sales, use, excise or similar tax imposed by federal, state, local or any other governmental authority applicable to the manufacture, sale, purchase or use of the Goods shall be paid by Buyer.

13. CHANGE IN DESIGN.

Seller, and or its suppliers, shall be entitled to make any and all changes in details of design, fabrication or arrangement of the Goods as Seller, and/or its suppliers, in its sole discretion determines will constitute an improvement upon the Goods or any specifications of designs previously furnished to Buyer.

14. PRODUCTS MADE TO BUYER'S SPECIFICATIONS.

Seller makes NO WARRANTY WHATSOEVER, except as to title, with respect to products manufactured, and/or designed to Buyer's own specifications and Buyer shall at its own expense, indemnify, defend and hold Seller harmless from and against any claim, suit, loss, fine, damages, action of any kind, judgment, liability, expense (including attorney fees) or otherwise which shall be asserted or brought against Seller by reason of its manufacturer or sale of such products.

15. INTELLECTUAL PROPERTY RIGHTS.

Buyer shall at all times recognize the validity of Seller's trademarks, copyrights, patents, service marks, proprietary designs and all other intellectual property and acknowledges that Buyer has no ownership or property rights therein. Buyer shall at all times exercise all commercially reasonable efforts to protect Seller's property rights in Seller's trademarks, service marks, patents, logos and all other intellectual property rights of Seller.

16. CERTIFICATES AND OTHER DOCUMENTATION.

Buyer will incur additional charges, the amount of which shall be determined in the sole discretion of Seller, for any requested certificates, additional documentation and third party examinations. Such additional charges shall be due at the time the invoice is due.

17. EXPORT CONTROL.

Any sale hereunder shall at all times be in strict conformity with all relevant export control laws and regulations, Buyer shall not make any disposition by way of transshipment, re-export, diversion or otherwise, of the Goods, except as said laws and regulations may expressly permit, and no such disposition or transfer will be made other than to the ultimate country of destination specified in the order or as declared

TERMS & CONDITIONS

as the country of ultimate destination on Seller's invoice.

18. SELLER'S BEST INTERESTS.

In the event Buyer is a reseller of Seller's products, Buyer shall at all times: (i) represent Seller and its products in good faith and in a professional manner, and (ii) not engage in any deceptive, misleading, illegal or unethical practices that may be detrimental to Seller or Seller's products. In addition to any of its remedies under the agreement between Buyer and Seller, at law or in equity, Seller reserves the right to terminate the agreement between Buyer and Seller and any other agreement between Buyer and Seller or any of Seller's affiliates in the event of any material breach by Buyer of its duties under this Section 18.

19. MISCELLANEOUS.

(a) Limitations of Action. No action against Seller for breach of the Terms of Sale as specified herein or otherwise relating to the Goods, including, but not limited to a breach of the warranties contained herein, shall be commenced more than one year after the accrual of the cause of action therefore.

(b) Assignment and Subcontracting. Buyer shall neither assign any rights nor delegate any duties under these Terms of Sale without the prior written consent of Seller. Seller may assign, license or subcontract to any of its affiliates all or any part of its rights and obligations under the terms of the agreement without Buyer's consent, provided Seller remains liable as primary obligor under the terms of the agreement.

(c) Conditions Incorporated by Reference. Any clause required to be included in a contract of this type by any applicable law or regulation shall be deemed to be incorporated herein.

(d) No Third Party Rights. Other than rights of Seller's affiliates under these Terms of Sale, no third parties will have any rights under these Terms of Sale.

(e) Construction. No provision of these Terms of Sale may be construed against Seller as the drafting party. Unless the context otherwise requires, all references herein to "Articles," "Sections," "Subsections," "paragraphs," "subparagraphs," and other subdivisions shall refer to the corresponding provisions of these Terms of Sale. Any reference to any federal, state, local, or foreign statute or law shall be deemed also to refer to all rules and regulations promulgated thereunder and successor laws, unless the context hereof requires otherwise. Whenever the term "including" or a similar term is used in these Terms of Sale, it shall be read as if it were written "including by way of example only and without in any way limiting the generality of the clause or concept referred to." References in these Terms of Sale to dollars or \$ means lawful money of the United States of America and all dollar amounts recited and payments required to be made pursuant to the agreement between Buyer and Seller shall be in lawful money of the United States of America. These Terms of Sale have been prepared in the English language, which shall be the official language for the agreement between Buyer and Seller. Any translations or other versions of these Terms of Sale are solely for the convenience of the parties and are not binding on the parties.

(f) Applicable Law. The Terms of Sale herein shall be governed by and construed in accordance with the laws of the State of Texas; exclusive venue shall lie in Harris County, Texas.

(g) Modification and Waiver. These Terms of Sale constitute the entire agreement between Buyer and Seller with regard to the subject matter hereof, and there are no understandings, representations, warranties or other provisions of any kind except as herein expressly set forth. No terms or conditions of any purchase order or other document of Buyer shall be part of the agreement between Buyer and Seller; and Seller expressly declines to accept any such provisions. Buyer's acceptance of the Goods and the sale thereof to Buyer is subject to the express condition that Buyer accept all terms and conditions hereof, and no alterations or modifications of this document shall be binding on Seller unless agreed to by Seller in writing. Seller and Buyer are relying solely on the terms, conditions, representations and warranties herein and upon no others, Seller and Buyer, being knowledgeable in these matters, having negotiated these Terms of Sale at arms length with availability of their respective legal counsel.

(h) Remedies. The remedies herein reserved to Seller shall be cumulative and in addition to any other or further remedies provided by law or at equity.

(i) Successors. These Terms of Sale shall be binding on and shall inure to the benefit of the parties' successors and assigns, subject to Paragraph (b) above in this Section 19.

(j) Severability. If any term, provision or condition contained herein is held to be illegal, invalid or unenforceable under present or future laws, then the legality, validity and enforceability of the remaining terms, provisions and conditions contained herein shall remain in full force and effect and not be affected thereby and these Terms of Sale shall be liberally construed so as to carry out the intent of the parties.

20. MEDIATION.

Any and all disputes arising between Seller and Buyer involving (i) the interpretation or application of the terms or provisions of or (ii) in any manner whatsoever relating to the Terms of Sale, which cannot be resolved between Seller and Buyer, shall, prior to the commencement of any legal action, be submitted for dispute resolution utilizing a mutually agreeable mediator and selecting a mutually convenient time and place for the mediation, which, unless circumstances require otherwise, shall occur not later than ninety (90) days after written notice is received by one of the parties hereto from the other party hereto that the dispute cannot be resolved by direct negotiations between the parties hereto.





3000, 6000 & 10000 PSI Bladder Accumulators	6
ASME & Alternate Design Codes	25
Bladder Accumulators	3
Bladder Accumulator Nitrogen Gas Boosters	23
Bladder Accumulator Mounting Collars	13
Bladder Accumulator Mounting Bases	14
Bladder Accumulator Mounting U-Bolts	15
Bladder Accumulator Ordering Table	5
Bladder Accumulator Overview	4
Bladder Accumulator Parts, Tools & Accessories	21
Bladder Accumulator Safety Blocks	22
Bladder & Bladder Kits	10
Bladder Elastomer Compatibility	9
Bladder Material Specifications	9
Bladder Special Orders	25
Bladder Kit Storage & Care	24
Catalog Overview	2
Charging & Gauging Assemblies for Bladder Accumulators	16
Maintenance Kits for Bladder Accumulators	20
Contact Accumulators, Inc.	1
Contents	1
Corrosion Protection Specifications	25
Custom Engineering & Fabrication	4
Diaphragm Accumulators	33
Diaphragm Accumulator Mounting Collars	38
Diaphragm Accumulator Ordering Table	35
Diaphragm Accumulator Overview	34
Engineering, Service, Support & Training	43
Float Accumulators	42
Fluid Port Assemblies	12
Frequently Asked Questions	47
Gas Storage Bottles	40
Gas Valve Specifications	11
HAZMAT Shipments & DOT Exemption	45
High-Flow Accumulators	8
Index	55
Original Equipment Limited Warranty	52
Permanent Mount Pressure Monitor for Bladder Accumulators	19
Piston Accumulators	27
Piston Accumulator Mounting Collars	32
Piston Accumulator Ordering Table	29
Piston Accumulator Overview	28
Piston Accumulator Specifications	30
Sales Terms & Conditions	52
Specialty Accumulator Products & Accessories	39
Special Order Bladder Accumulators	25
Transfer Barrier Accumulators	7
Training	46
Welded Diaphragm Accumulators	37



ISO 9001 CERTIFIED
www.accumulators.com

18435 Morton Road Houston, TX 77084 USA | www.accumulators.com | info@accumulators.com
p: 713.465.0202 | f: 713.468.1618

2018:08 REVISION

This publication is available for distribution. Please contact our sales department for copies.

© Copyright Accumulators, Inc. The names "Accumulators, Inc.", "accumulators.com" and variations, "Acc.Inc." and "AccuMight" and derivation are registered trademarks and service marks of Accumulators, Inc. Various Accumulators, Inc. designs are protected by U.S. and foreign patents. Various patents pending.