

# 1T15M-9 Firestone



Description		Assembly Order No.
Style 1T15M-9	Blind nuts, 1/4 NPT	WO1-358-9108
	Blind nuts, 1/4 NPT, bumper	WO1-358-9104
Two Ply Bellows	Blind nuts, 3/4 NPT	WO1-358-9106
	Blind nuts, 3/4 NPT, bumper	WO1-358-9117
Assembly weight .....		18.0 lbs.

Recommended Design Position Static Pressure 0-100 psi

CONSULT FIRESTONE BEFORE USING AS AIRMOUNT

RECOMMENDED AIRMOUNT DESIGN HEIGHT 17.0 INCHES

Static Data 3797

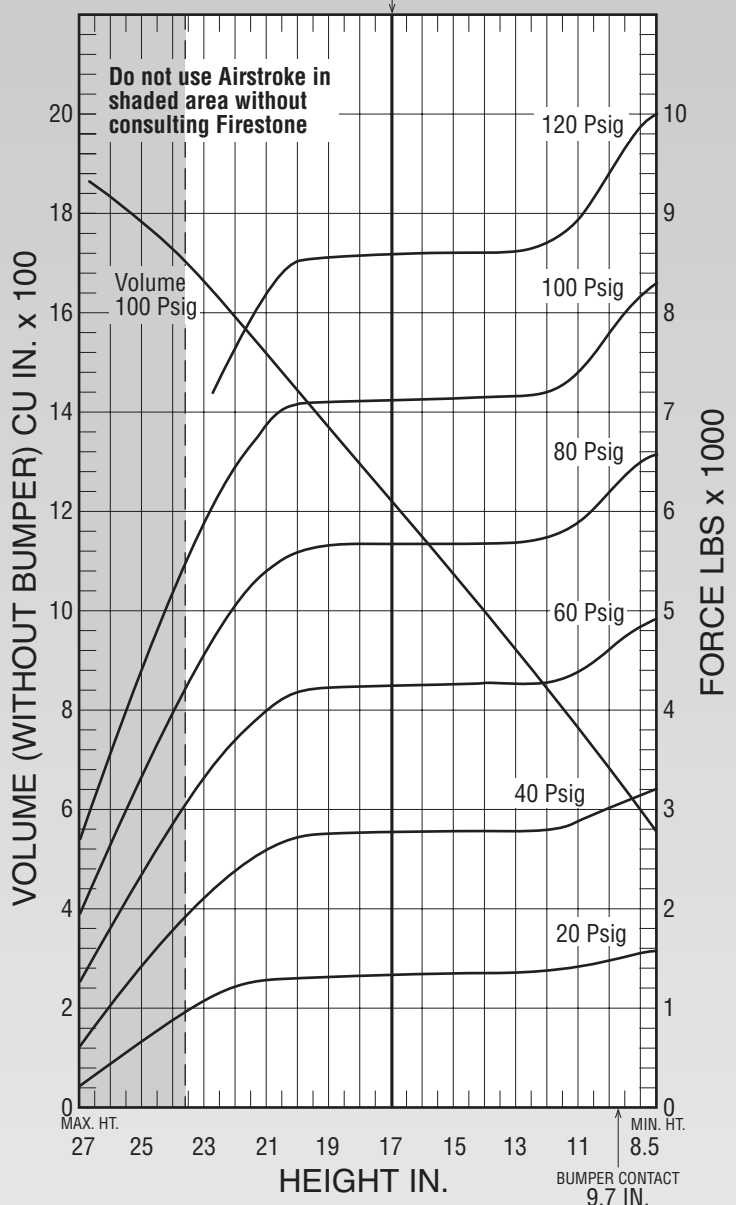
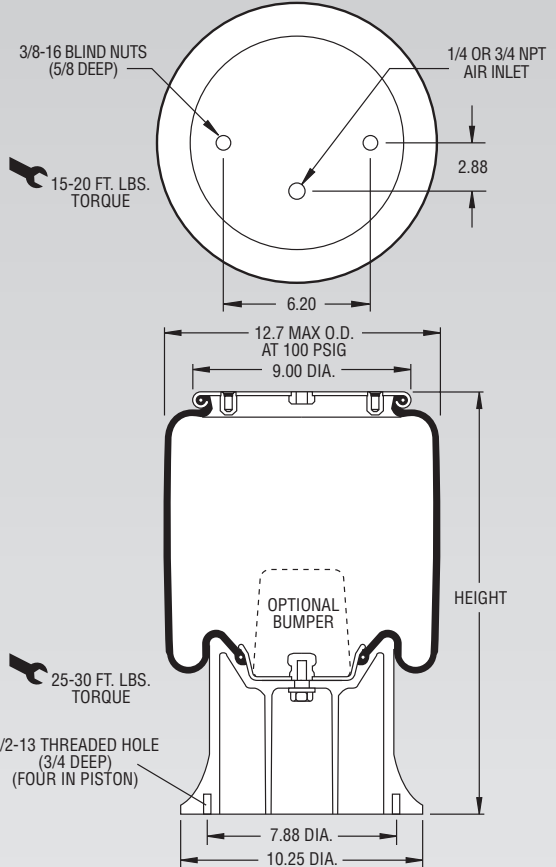

**NOTE:** Bellows will not compress properly with less than 10 PSIG internal pressure.

**NOTE:** A bead plate part is shown. This part is also available with a bead ring. Bolts are not included. See pages 8-10 for explanation.

Dynamic Characteristics at 17.0 in. Design Height (Required for Airmount isolator design only)				
Volume @ 100 PSIG = 1,217 in <sup>3</sup>			Natural Frequency	
Gage Pressure (PSIG)	Load (lbs.)	Spring Rate (lbs./in.)	CPM	HZ
40	2,770	287	60	1.01
60	4,250	425	59	.99
80	5,680	546	58	.97
100	7,140	659	57	.95

See page 12 for instructions on how to use chart.

Force Table (Use for Airstroke™ actuator design)						
Assembly Height (in.)	Volume @ 100 PSIG (in <sup>3</sup> )	Pounds Force				
		@20 PSIG	@40 PSIG	@60 PSIG	@80 PSIG	@100 PSIG
23.0	1,658	1,090	2,150	3,340	4,560	5,850
21.0	1,517	1,290	2,600	4,020	5,380	6,860
19.0	1,368	1,340	2,780	4,240	5,660	7,110
17.0	1,217	1,370	2,770	4,250	5,680	7,140
15.0	1,067	1,380	2,810	4,290	5,690	7,150
13.0	916	1,390	2,810	4,280	5,700	7,170
11.0	760	1,460	2,950	4,430	5,940	7,500
9.0	596	1,580	3,200	4,880	6,550	8,230