

Description		Assembly Order No.
Style 115	Blind nuts, 1/4 NPT	W01-358-7460
	Blind nuts, 1/4 NPT rubber bumper	W01-358-7459
Two Ply Bellows	Blind nuts, 3/4 NPT	W01-358-7465
	Blind nuts, 3/4 NPT rubber bumper	W01-358-7458
	Countersunk steel bead rings, 1 5/8 bolts, nuts, washers	W01-358-7469
	Blind nuts, 3/4 NPT both ends (centered)	W01-606-7115
	Rubber bellows only	W01-358-0118
Assembly weight.....		5.7 lbs.
Force to collapse to minimum height (@ 0 PSIG) .....		8 lbs.
Style 124	Blind nuts, 1/4 NPT	W01-358-7650
	Blind nuts, 3/4 NPT	W01-358-7649
High Strength Bellows		

Recommended Design Position Static Pressure 0-100 psi

RECOMMENDED AIRMOUNT DESIGN HEIGHT 4.5 INCHES

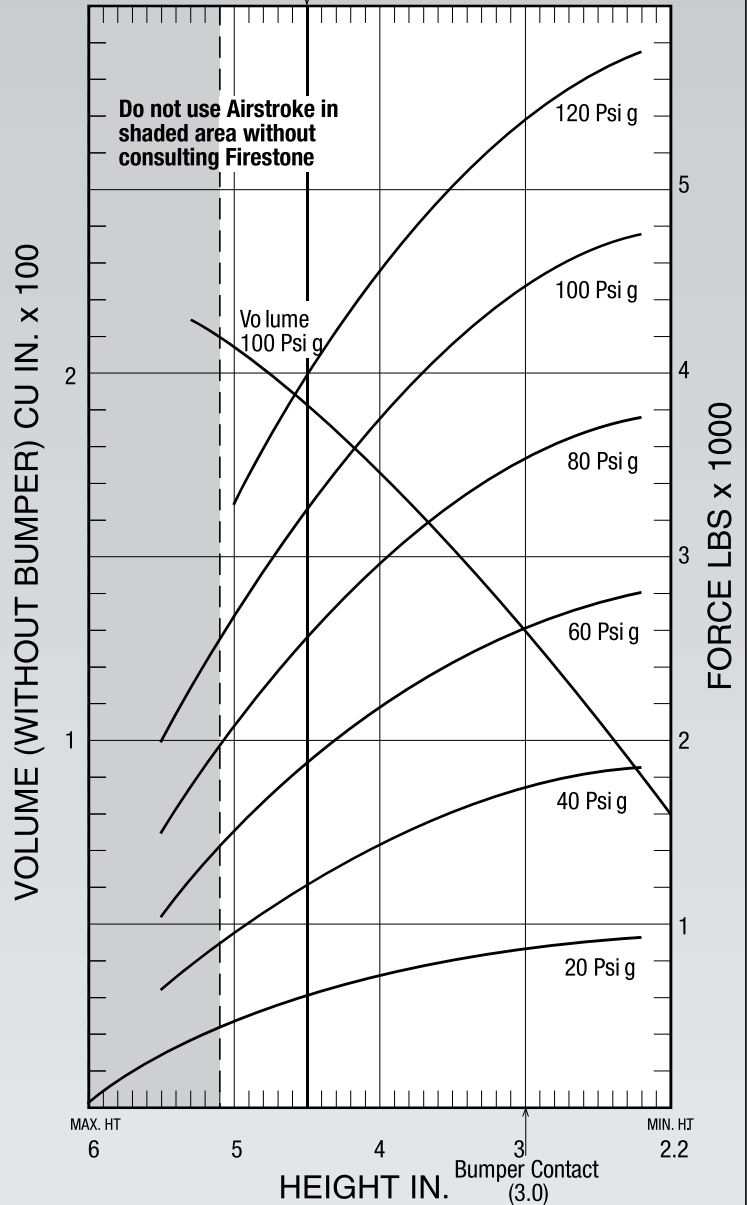

See page 12 for instructions on how to use chart.

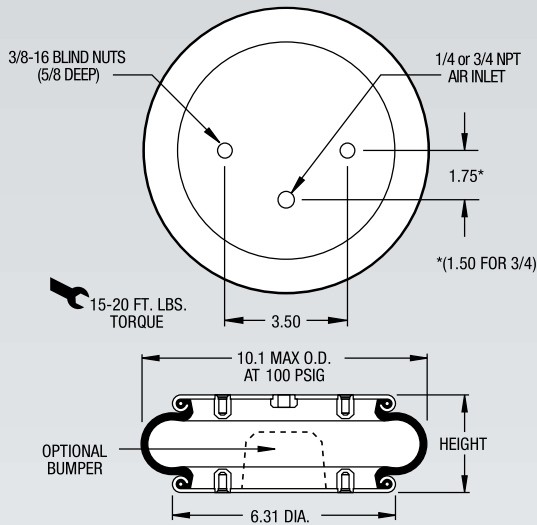

**NOTE: A bead plate part is shown. This part is also available with bead rings. See pages 8-10 for explanation.**

Dynamic Characteristics at 4.5 in. Design Height (Required for Airmount isolator design only)				
Volume @ 100 PSIG = 192 in <sup>3</sup>			Natural Frequency	
Gage Pressure (PSIG)	Load (lbs.)	Spring Rate (lbs./in.)	CPM	HZ
40	1,210	900	162	2.70
60	1,880	1,264	154	2.57
80	2,540	1,638	151	2.52
100	3,270	2,027	148	2.47

Force Table (Use for Airstroke™ actuator design)						
Assembly Height (in.)	Volume @ 100 PSIG (in <sup>3</sup> )	Pounds Force				
		@20 PSIG	@40 PSIG	@60 PSIG	@80 PSIG	@100 PSIG
5.0	209	470	960	1,520	2,080	2,690
4.0	174	700	1,430	2,180	2,940	3,750
3.0	130	820	1,720	2,630	3,510	4,440