

Description		Assembly Order No.
Style 16	Blind nuts, 1/4 NPT	W01-358-7001
	Blind nuts, 3/4 NPT	W01-358-6996
Two Ply Bellows	Socket head aluminum bead rings (bolts, nuts, washers not included-use 1/4 cap screws)	W01-358-0017
	3/4 NPT (only) upper plate, blind nuts lower plate	W01-358-0286
	Rubber bellows only	W01-358-0010
Assembly weight.....		2.5 lbs.
Force to collapse to minimum height (@ 0 PSIG)		30 lbs.

Recommended Design Position Static Pressure 0-100 psi

RECOMMENDED AIRMOUNT DESIGN HEIGHT 3.0 INCHES

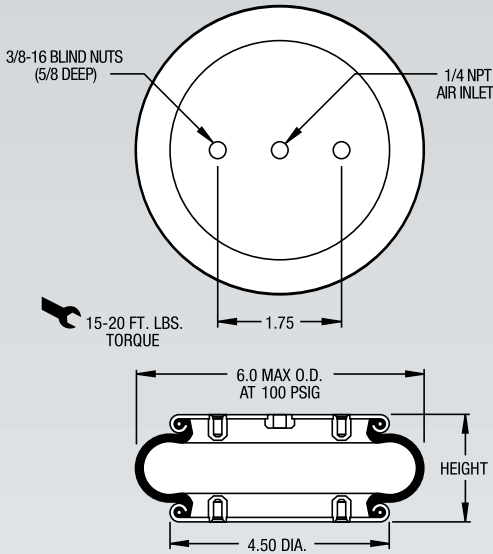

NOTE: A bead plate part is shown. This part is also available with bead rings. Bolts are not included. See pages 8-10 for explanation.

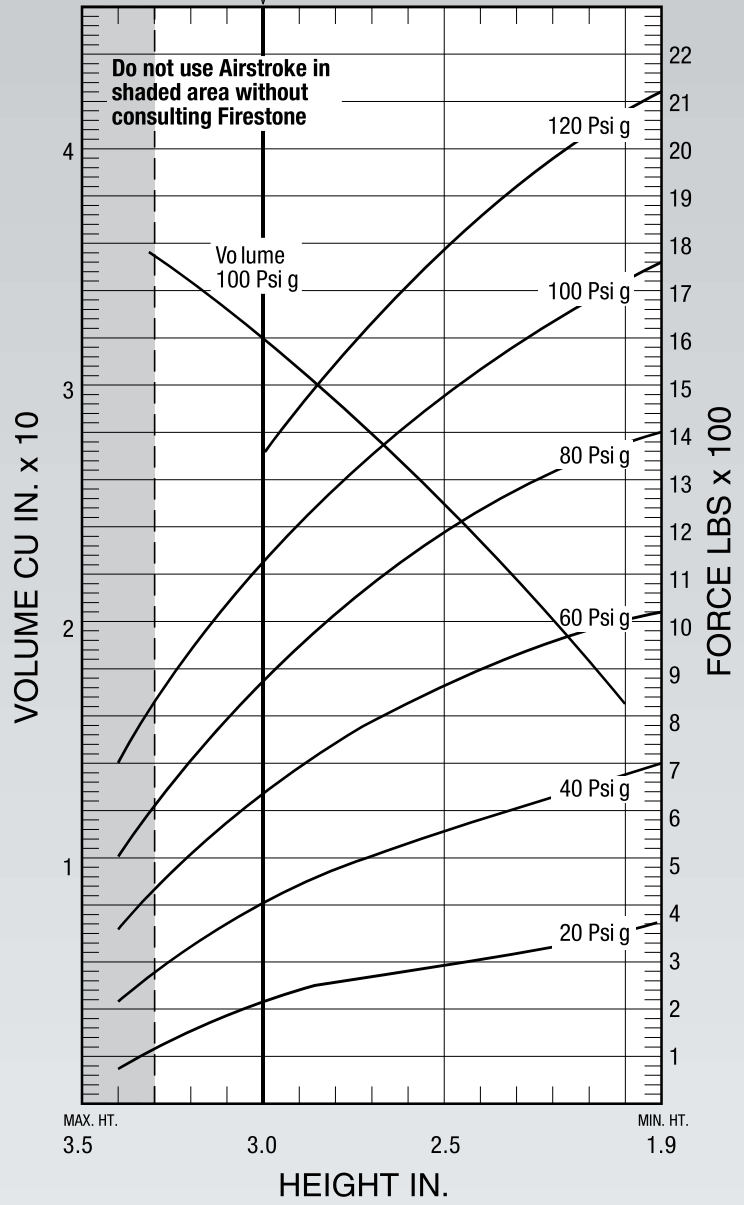

See page 12 for instructions on how to use chart.

Dynamic Characteristics at 3.0 in. Design Height (Required for Airmount isolator design only)				
Volume @ 100 PSIG = 32 in ³			Natural Frequency	
Gage Pressure (PSIG)	Load (lbs.)	Spring Rate (lbs./in.)	CPM	HZ
40	420	765	254	4.24
60	640	1,088	244	4.07
80	880	1,410	237	3.96
100	1,120	1,710	232	3.86

Force Table (Use for Airstroke™ actuator design)						
Assembly Height (in.)	Volume @ 100 PSIG (in ³)	Pounds Force				
		@20 PSIG	@40 PSIG	@60 PSIG	@80 PSIG	@100 PSIG
3.0	32	220	420	640	880	1,120
2.0	17	350	680	1,020	1,370	1,720