

Description		Assembly Order No.
Style 1M1A-0	Blind nut, 1/8 NPT, plastic stud	W02-358-3000
Two Ply Bellows	Blind nut, 1/8 NPT, brass stud	W02-358-3001
	Blind nut, 1/8 NPT, brass stud, stainless steel ring	W02-358-3005
Assembly weight.....		0.5 lbs.
Force to collapse to minimum height (@ 0 PSIG).....		20 lbs.

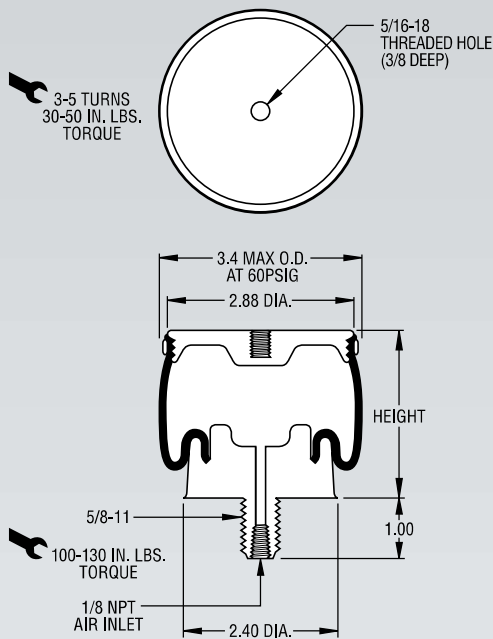

Recommended Design Position Static Pressure 0-100 psi

RECOMMENDED AIRMOUNT DESIGN HEIGHT 2.5 INCHES

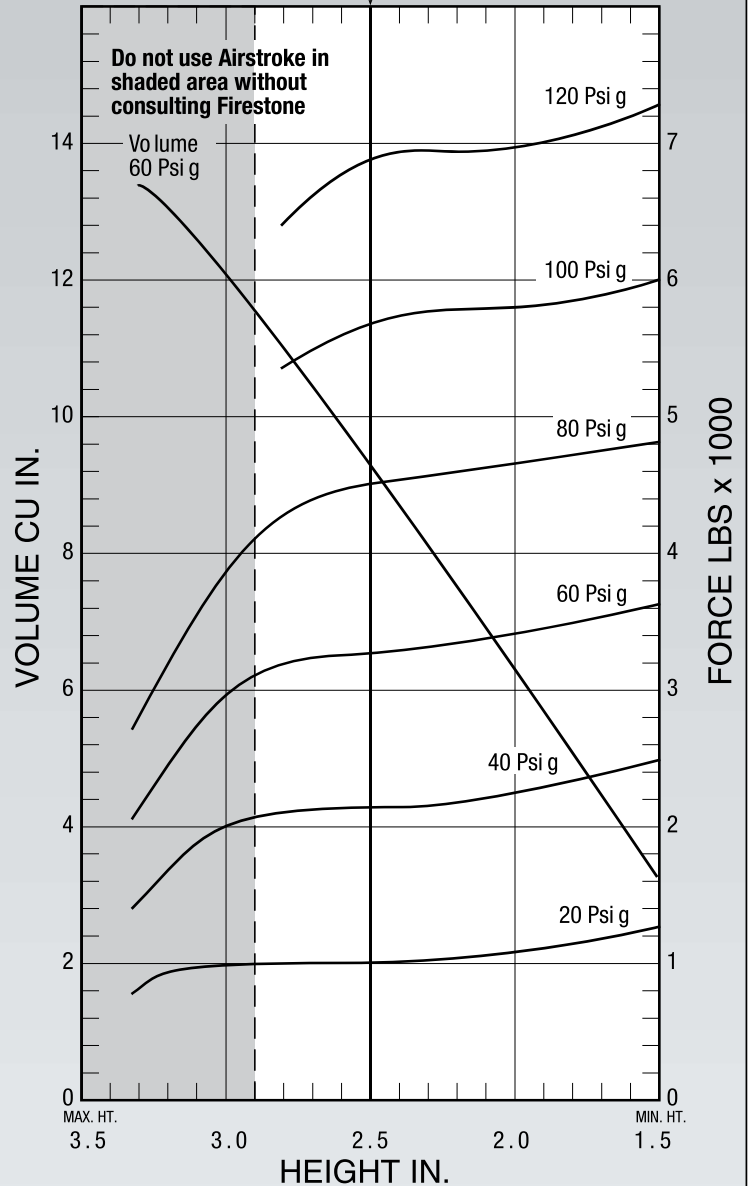

See page 12 for instructions on how to use chart.

Dynamic Characteristics at 2.5 in. Design Height
(Required for Airmount isolator design only)

Volume @ 60 PSIG = 9.2 in ³			Natural Frequency	
Gage Pressure (PSIG)	Load (lbs.)	Spring Rate (lbs./in.)	CPM	HZ
40	210	336	235	3.92
60	330	467	224	3.73
80	450	619	220	3.67
100	570	740	214	3.57

Force Table (Use for Airstroke™ actuator design)

Assembly Height (in.)	Volume @ 60 PSIG (in ³)	Pounds Force				
		@20 PSIG	@40 PSIG	@60 PSIG	@80 PSIG	@100 PSIG
2.0	6	110	230	340	460	580