

Description		Assembly Order No.
Style 268	Blind nuts, 1/4 NPT	W01-358-7025
	Blind nuts, 3/4 NPT	W01-358-7047
Two Ply Bellows	Blind nuts, 1/4 NPT both ends	W01-358-7035
	3/4 NPT both ends (no blind nuts)	W01-606-7025
	Socket head aluminum bead rings (bolts, nuts, washers not included, use cap screws)	W01-358-0030
	3/4 NPT (only) upper plate, blind nuts lower plate	W01-358-7030
	Rubber bellows only	W01-358-0319
Assembly weight.....		3.2 lbs.
Force to collapse to minimum height (@ 0 PSIG)		30 lbs.

Recommended Design Position Static Pressure 0-100 psi

RECOMMENDED AIRMOUNT DESIGN HEIGHT 5.5 INCHES

NOTE: Replacement for Style 25

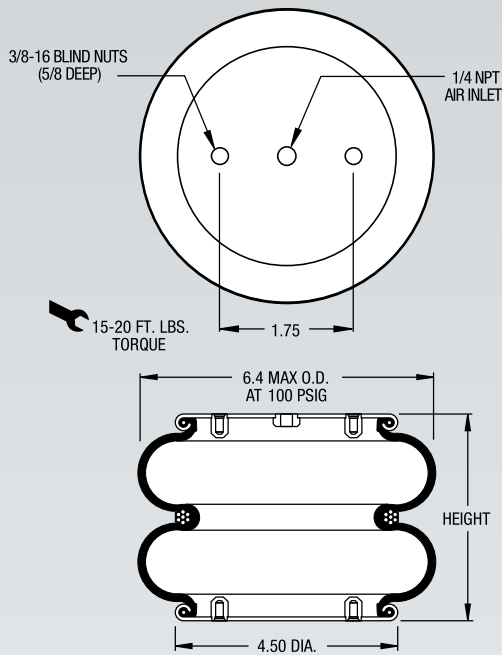

NOTE: A bead plate part is shown. This part is also available with bead rings. Bolts are not included. See pages 8-10 for explanation.

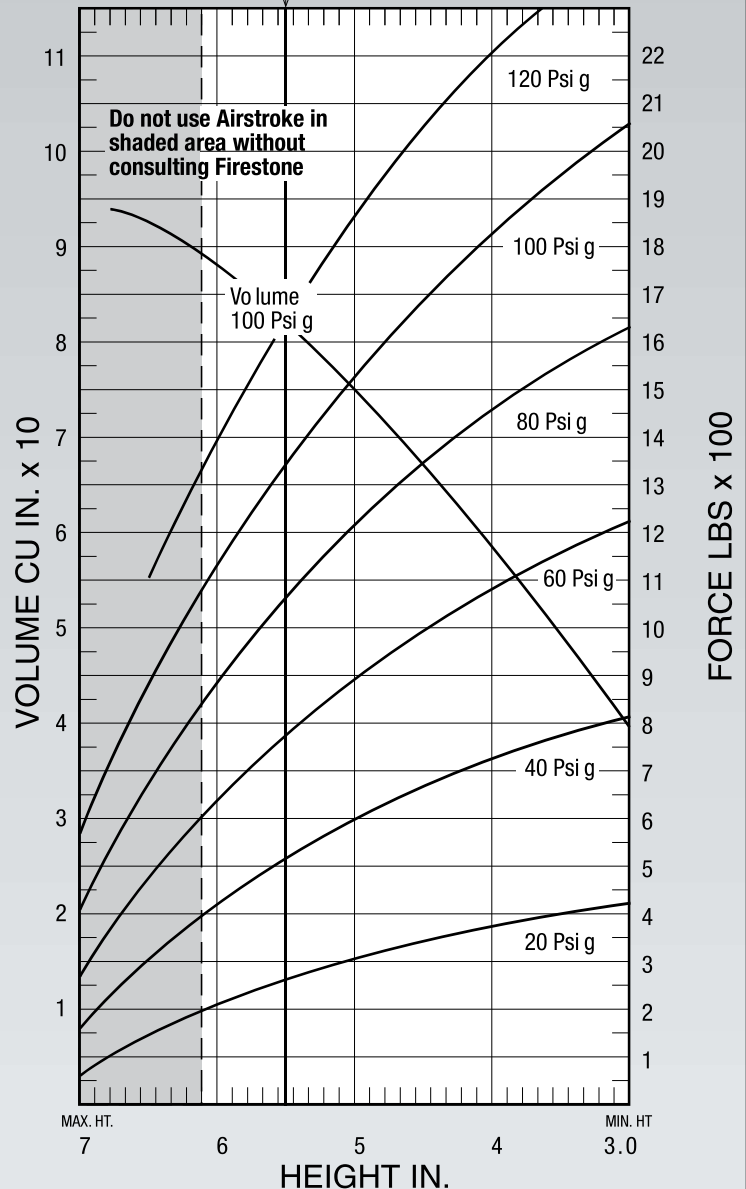

See page 12 for instructions on how to use chart.

Dynamic Characteristics at 5.5 in. Design Height (Required for Airmount isolator design only)				
Volume @ 100 PSIG = 86 in ³			Natural Frequency	
Gage Pressure (PSIG)	Load (lbs.)	Spring Rate (lbs./in.)	CPM	HZ
40	515	339	153	2.54
60	787	482	147	2.45
80	1,062	634	145	2.42
100	1,360	773	141	2.36

Force Table (Use for Airstroke™ actuator design)						
Assembly Height (in.)	Volume @ 100 PSIG (in ³)	Pounds Force				
		@20 PSIG	@40 PSIG	@60 PSIG	@80 PSIG	@100 PSIG
5.0	78	300	590	890	1,210	1,540
4.0	60	380	720	1,080	1,450	1,810
3.0	39	420	800	1,220	1,640	2,060