

### Option selector

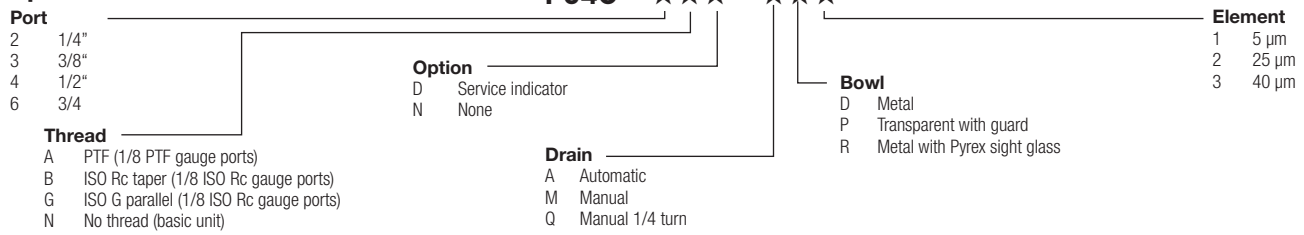

### Technical features

Fluid: Compressed air  
 Maximum pressure:  
 Guarded transparent bowl: 10 bar (150 psig)  
 Metal bowl: 17 bar (250 psig)  
 Operating temperature\*:  
 Transparent bowl: -20° ... +50°C (0° ... +125°F)  
 Metal bowl: -20° ... +80°C (0° ... +175°F)  
 \* Air supply must be dry enough to avoid ice formation at temperatures below +2°C (+35°F).  
 Particle removal: 5 µm, 25 µm or 40 µm filter element  
 Air quality: Within ISO 8573-1, Class 3 and Class 5 (particulates)  
 Typical flow with 40 µm element, 6,3 bar (90 psig) inlet pressure and 0,5 bar (7 psig) droop from set: 70 dm³/s (148 scfm)  
 Automatic drain connection: 1/8"  
 Automatic drain operating conditions:  
 Pressure: 0,7 bar (10 psig). Drain opens when bowl pressure drops below 0,2 bar (3 psig).  
 Minimum air flow: 1 dm³/s (2 scfm) required to close drain  
 Nominal bowl size: 0,2 litre (7 fluid oz)  
 Materials:  
 Body: Zinc  
 Bowl:  
 Metal: Aluminium  
 Transparent, optional: Polycarbonate  
 Metal bowl liquid level indicator lens, standard: Grilamid  
 Metal bowl sight glass, optional: Pyrex  
 Element: Sintered plastic  
 Elastomers: Synthetic rubber

### Replacement Items

Service kit, contains required items circled:

	4380-200
Prismatic sight glass	4380-040
Pyrex sight glass	4380-041
Filter element, 5 µm	4338-01
Filter element, 40 µm	4338-02
Manual drain	684-84
Automatic drain	3000-97
Mechanical service Indicator (1)	5797-50

### Installation

- Install unit vertically in air line -
  - vertically (bowl down),
  - with air flow in direction of arrow on body,
  - upstream of regulators, lubricators, and cycling valves,
  - as close as possible to the air supply when used as a main line filter,
  - as close as possible to the device being serviced when used as a final filter.
- Before assembling the basic unit into the yoke the port seal o-rings should be lightly smeared with o-ring grease.
- Locate clamp ring under lugs on top of yoke, offer basic unit into yoke with directional

- arrows correctly aligned (an interference fit prevents assembly if misaligned) before engaging and fully tightening the clamp ring.
- Turn bowl or bowl guard fully clockwise into body before pressurizing. Lock symbols on body and bowl guards must align.
  - Auto-drain units may be fitted with a short drain pipe and connector, minimum 5 mm bore, to the G1/8 bottom outlet.

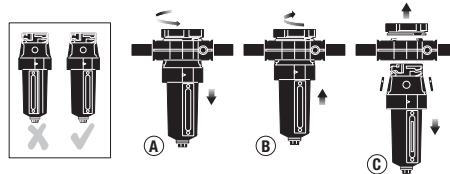

### Servicing

- Open manual drain to expel accumulated liquids. Keep liquids below baffle (53).
- To operate automatic drain manually, lift operating pin in bottom outlet with a blunt rod.
- Clean or replace filter element when dirty.

### Disassembly

- Shut off inlet pressure. Reduce pressure in inlet and outlet lines to zero.
- For ease of maintenance the unit can be removed from the yoke by unscrewing the clamp ring, which will jack the unit out downwards.
- Lift and turn the filter bowl counterclockwise and remove with bowl o-ring.
- Disassemble in general accordance with the item numbers on exploded view. Do not remove the drains or the service indicator unless replacement is necessary. Remove and replace only if they malfunction.

### Cleaning

- Partial cleaning of the filter element is possible by washing the element in soapy water and blowing out thoroughly with compressed air. Replacement by a clean element is recommended. Clean plastic bowl and lens (45) with warm water only. Clean other parts with warm water and soap.
- Rinse and dry parts. Blow out internal passages in body with clean, dry compressed air.
- Inspect parts. Replace those found to be damaged. Replace plastic bowl with a metal bowl if plastic bowl shows signs of cracking or cloudiness.

### Assembly

- Lubricate o-rings with o-ring grease.
- Assemble the unit as shown on the exploded view.

### 3. Torque Table

Item	Torque in N-m	(Inch-Pounds)
55 (Filter guide)	2,0 ... 2,7 max	(18 ... 25)
4. Assemble baffle (53), contact + 1/4 turn.		
5. Turn bowl or bowl with guard fully clockwise into body.		

### Caution

Water vapor will pass through these units and could condense into liquid form downstream as air temperature drops. Install an air dryer if water condensation could have a detrimental effect on the application.

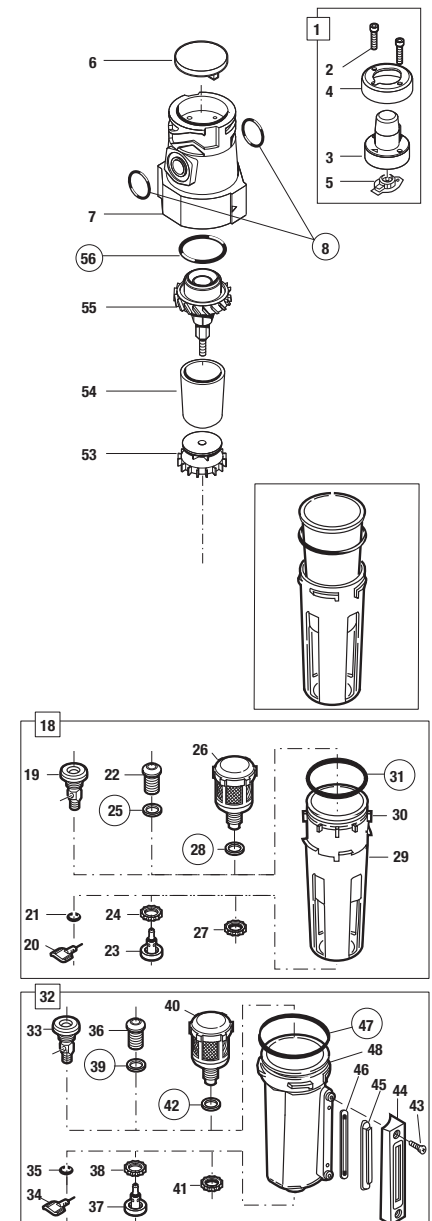

**WARNING**

These products are intended for use in industrial compressed air systems only. Do not use these products where pressures and temperatures can exceed those listed under Technical Data.

Polycarbonate plastic bowls can be damaged and possibly burst if exposed to such substances as certain solvents, strong alkalis, compressor oils containing ester-based additives or synthetic oils. Fumes of these substances in contact with the polycarbonate bowl, externally or internally, can also result in damage. Clean with warm water only.

Use metal bowl in applications where a plastic bowl might be exposed to substances that are incompatible with polycarbonate.

Before using these products with fluids other than air, for non industrial applications, or for life-support systems consult Norgren.

**Use in potentially explosive atmospheres**

Code of device according EC directive 94/9/EC Ex II 2 GD c TX

- Only non-flammable gases to be used as a medium.
- Surface temperature dependant on process fluid temperature and ambient temperature must be below the ignition temperature of the flammable gas or dust.
- Earth unit and/or pipework to avoid electrostatic discharge.
- Precautions should be taken to prevent hazard from adiabatic compression.
- Use wet cloth for cleaning.
- Protect the unit from object falling onto it.
- Avoid contact with corrosive environment.
- For servicing the unit it is recommended to carry out this work outside of the danger zone.
- For details of ignition hazard assessment contact Norgren.