

**NOTE: Replacement for Style 20**

Description		Assembly Order No.
Style 274	Blind nuts, 1/4 NPT	W01-358-6910
	Blind nuts, 1/4 NPT, bumper	W01-358-6911
Two Ply Bellows	Blind nuts, 3/4 NPT	W01-358-6900
	Blind nuts, 3/4 NPT, bumper	W01-358-6901
	Countersunk steel bead rings, 1 3/4 bolts, nuts, washers	W01-358-6923
	Rubber bellows only	W01-358-0138

Assembly weight..... 7.0 lbs.

Force to collapse to minimum height (@ 0 PSIG)..... 14 lbs.

Style 202	Blind nuts, 1/4 NPT	W01-358-7080
High Strength Bellows	Blind nuts, 3/4 NPT	W01-358-7119

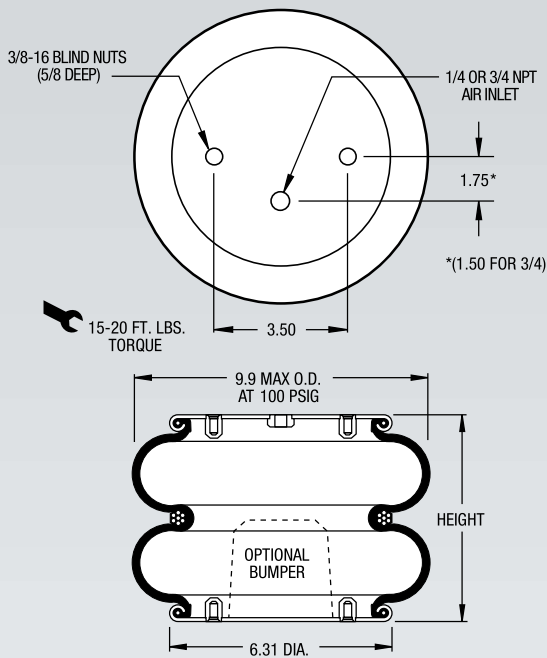

**NOTE: A bead plate part is shown. This part is also available with bead rings. See pages 8-10 for explanation.**

Dynamic Characteristics at 8.5 in. Design Height (Required for Airmount isolator design only)				
Volume @ 100 PSIG = 376 in <sup>3</sup>			Natural Frequency	
Gage Pressure (PSIG)	Load (lbs.)	Spring Rate (lbs./in.)	CPM	HZ
40	990	414	121	2.02
60	1,540	615	119	1.98
80	2,130	820	116	1.94
100	2,720	996	114	1.89

Recommended Design Position Static Pressure 0-100 psi

RECOMMENDED AIRMOUNT DESIGN HEIGHT 8.5 INCHES

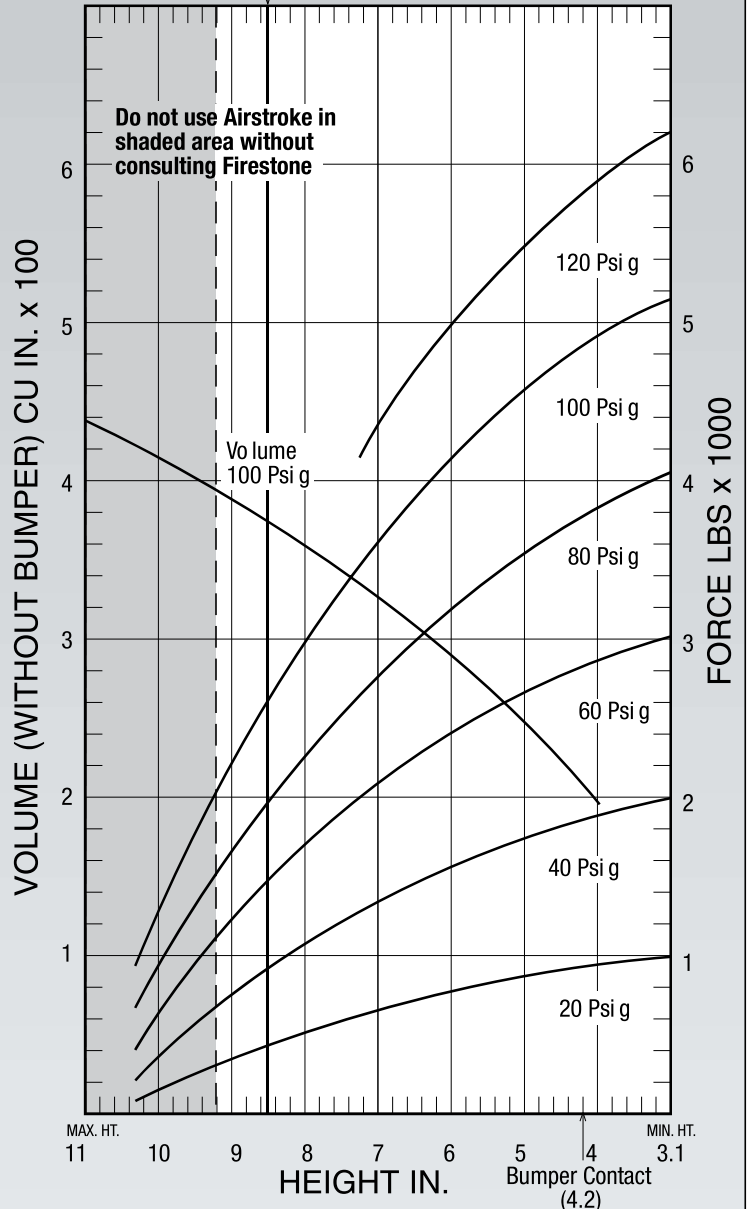

See page 12 for instructions on how to use chart.

Force Table (Use for Airstroke™ actuator design)						
Assembly Height (in.)	Volume @ 100 PSIG (in <sup>3</sup> )	Pounds Force				
		@20 PSIG	@40 PSIG	@60 PSIG	@80 PSIG	@100 PSIG
9.0	392	392	770	1,195	1,642	2,114
8.0	365	576	1,128	1,713	2,309	2,940
7.0	331	707	1,396	2,104	2,832	3,582
6.0	291	806	1,601	2,410	3,237	4,082
5.0	247	903	1,796	2,702	3,624	4,562
4.0	197	993	1,966	2,953	3,948	4,958