

Assembly Order No.	Rubber Material	F1	F2	F3	Clamp Ring	Body Material	Max Restricted Pressure (psig/bar)	Max Unrestricted Pressure (psig/bar)
WP1-M58-0005	Neoprene	M5	M5	N/A	Stainless Steel	Steel	70 / 5	35 / 2.4
WP1-M58-0024	Silicone	M5	M5	N/A	Stainless Steel	Steel	25 / 1.8	15 / 1
WP1-358-2001	Neoprene	10--32 UNF	10--32 UNF	N/A	Stainless Steel	Steel	70 / 5	35 / 2.4
WP1-358-2009	Silicone	10--32 UNF	10--32 UNF	N/A	Stainless Steel	Steel	25 / 1.8	15 / 1

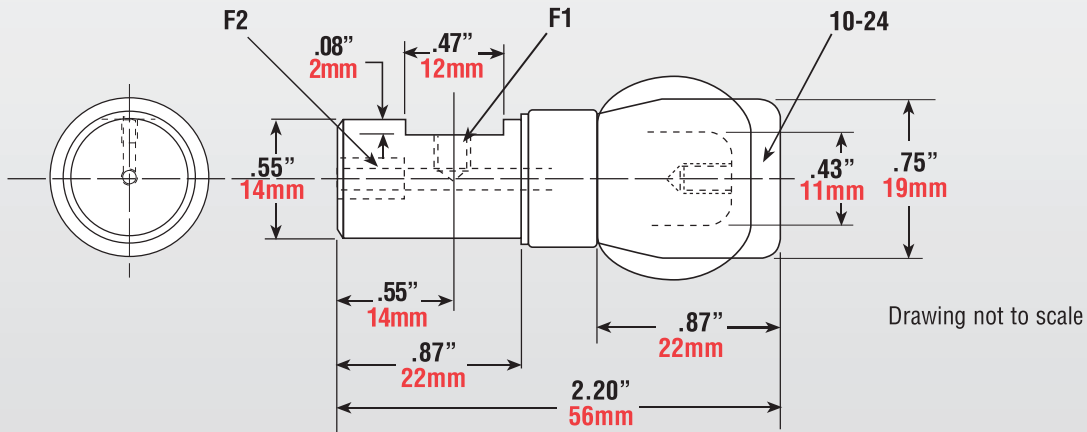

IMPERIAL

FORCE CURVES

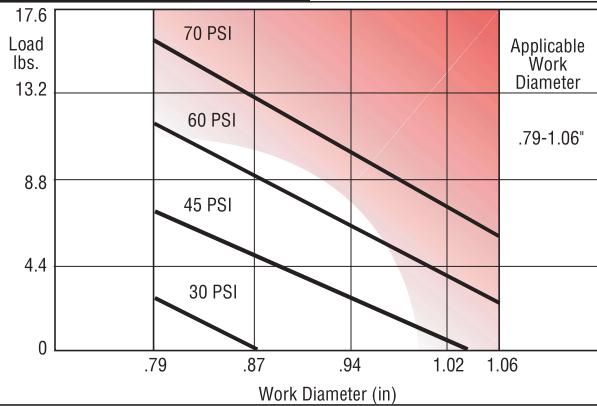

PRESSURE VS INFLATED DIAMETER

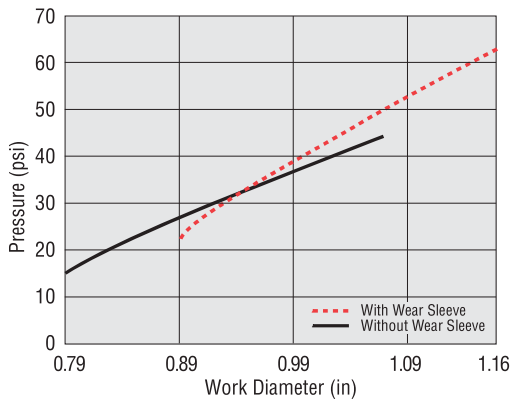

METRIC

FORCE CURVES

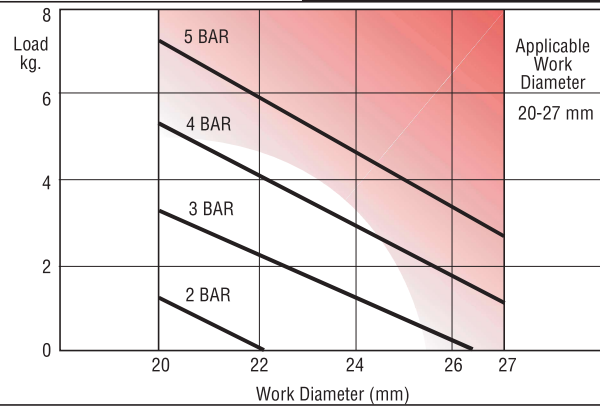

PRESSURE VS INFLATED DIAMETER

